



WILLMAR CITY COUNCIL MEETING  
MONDAY, APRIL 6, 2026 @ 6:30 PM  
BOARD ROOM HEALTH AND HUMAN SERVICES BUILDING  
2200 – 23rd STREET NE, WILLMAR MINNESOTA

### AGENDA

1. Call Meeting to Order
2. Roll Call
3. Pledge of Allegiance
4. Proposed Additions or Deletions to Agenda
5. Consent Items

Approve:

- A. City Council Minutes of March 16, 2026
- B. Parks & Recreation November 2025 Board Meeting Minutes
- C. Willmar Municipal Utilities Commission Minutes of March 23, 2026, Draft
- D. Willmar Municipal Utilities Commission Applicant
- E. Project No. 2608 Seal Coat/Crack Seal Improvements Plans & Specs., Authorize Ad for Bids
- F. Project No. 2605-B Stormwater Capital Improvements Plans & Specs., Authorize Solicitation of Quotes
- G. Business 71 Bridge Maintenance Project Plans & Specs., Authorize Ad for Bids
- H. TH 40 Turnlane Project Plans & Specs., Authorize Ad for Bids
- I. Subaward Agreement with the Connected Communities Project — Bethesda Foundation
- J. Willmar Community Theatre Lawful Gambling Application
- K. Willmar Firefighters Association Lawful Gambling Application
- L. Accounts Payable Report, 3/12/2026 - 4/2/2026

Information:

- M. Airport Commission and Human Rights Commission Applicants
- N. Monthly Building Report March 2026

6. Approve Consent Agenda Items
7. Items Removed from Consent Agenda
8. Open Forum (Individuals Limited to Three (3) Minutes)
9. Regular Business
  - A. State of the City Address - Mayor Reese

- B. Kandiyohi County Economic Development Housing Study Introduction
- C. Approving the plans and specifications and authorizing advertisement for bids for the Robbins Island Amphitheater Project.
- D. Consideration of Awarding Sale of General Obligation Tax Abatement Bonds, Series 2026A
- E. City Hall Elevator Modernization Upgrades
- F. Introduction of an Ordinance Amending Willmar Municipal Code, Chapter 8
- G. Consideration of the Cannabis Registration Application Process
- H. Sale of Low-Potency Hemp Edible Retail 2026 Registration
- I. Consideration of Spurs Grill and Bar On-Sale Intoxicating and Sunday Liquor Licenses
- J. Resolution to Acknowledge Donations for the First Quarter of 2026
- K. Request for Joint Work Session Monday, April 13, 2026

10. Announcements

11. Recess for a Closed Session

- A. Minn. Stat. § 13D.05, subd. 3(c) - Parcels 95-003-4820, 95-003-4830 and 95-003-4940

12. Adjourn

**WILLMAR CITY COUNCIL PROCEEDINGS**  
**BOARD ROOM HEALTH AND HUMAN SERVICES BUILDING**  
**2200 – 23rd STREET NE, WILLMAR MINNESOTA**

March 16, 2026  
6:30 PM

The regular meeting of the Willmar City Council was called to order by Mayor Douglas Reese. Members present on a roll call were Mayor Douglas Reese, Council Members Justin Ask, Audrey Nelsen, Tom Gilbertson, Steve Gardner, Rick Fagerlie, Vicki Davis, and Carl Shuldes, Excused: Tom Butterfield, Present 8, Absent 1.

Also present were City Administrator Leslie Valiant, City Operations Director Kyle Box, Police Chief Michael Holme, Finance Director Tom Odens, Parks and Recreation Director Rob Baumgarn, Planning and Development Director Christopher Corbett, Human Resource Director Alissa Gambrel, Public Works Director Shane Stefanick, City Engineer Jared Voge, Director of Community Growth Pablo Obregon, Information Systems Director Jonah Johnson, Environmental Specialist Sara Sietsema, City Clerk Vernae Larsen, and City Attorney Robert Scott.

There were no additions or deletions to the agenda. Council Member Ask moved to **Approve the Agenda as presented**. Council Member Davis seconded the motion, which carried on a roll call vote of Ayes 7, Noes 0.

Ayes        Council Member Ask, Council Member Nelsen, Council Member Gilbertson,  
              Council Member Gardner, Council Member Fagerlie, Council Member Davis,  
              Council Member Shuldes  
Noes        None

**CONSENT AGENDA**

City Clerk Vernae Larsen reviewed the consent agenda.

Approve:

- A. City Council Minutes of March 2, 2026
- B. Planning Commission Minutes of March 4, 2026\_Draft
- C. Willmar Municipal Utilities Commission Minutes of March 9, 2026, Draft
- D. **Resolution No. 2026-026** Accept and Final Project No. 2503-D Business 71
- E. **Resolution No. 2026-027** Advertisement for Bids: Airport Snow Removal Equipment Acquisition
- F. **Resolution No. 2026-028** Approve AFSCME Public Works Unit 2026-2028 Agreement
- G. Memorandum of Agreement between the City of Willmar and LELS Unit
- H. **Resolution No. 2026-029** Advertisement Agreement with the Willmar Softball Association

- I. **Resolution No. 2026-030** Advertisement Agreement with the Willmar High School Softball Boosters
- J. **Resolution No. 2026-031** Concession Stand Agreement with the Willmar High School Softball Boosters
- K. **Resolution No. 2026-032** Concession Stand Agreement with the Willmar Softball Association
- L. Planning Commission and Zoning Appeals Board Applicants
- M. Liquor License Renewals
- N. Civic Center Arena Special Event by On-Sale Liquor License Holder Permit—Green Mill Willmar
- O. Accounts Payable Report, 2/26/2026 - 3/11/2026

Information:

- P. Review Willmar Municipal Utilities Commission Applicant
- Q. Director Reports
- R. WMU Financial Report for January 2026
- S. Finance Report for February 2026
- T. Monthly Building Report February 2026
- U. Monthly Building Report for January 2026

A motion was made by Council Member Gilbertson to **Approve Consent Agenda Items as presented**. Council Member Shuldes seconded the motion, which carried on a roll call vote of Ayes 7, Noes 0.

Ayes Council Member Ask, Council Member Nelsen, Council Member Gilbertson, Council Member Gardner, Council Member Fagerlie, Council Member Davis, Council Member Shuldes

Noes None

**REGULAR BUSINESS**

**A. Willmar Civic Center-Blue Line Arena Roof Project**

Parks and Rec Director Rob Baumgarn gave an overview of the condition of the original roof on the Blue Line Arena and the need for replacement. Council Member Fagerlie made a motion to **Adopt Resolution No. 2026-033 accepting the proposal from The Jamar Company for the replacement of the Blue Line Arena roof in the amount of \$263,797**. Council Member Gilbertson seconded the motion, which carried on a roll call vote of Ayes 7, Noes 0.

Ayes Council Member Ask, Council Member Nelsen, Council Member Gilbertson, Council Member Gardner, Council Member Fagerlie, Council Member Davis, Council Member Shuldes

Noes None

**B. Iverson Park Lift Station Bid Award**

City Engineer Jared Voge presented the staff report regarding the Iverson Park lift station project including the bids received for that project. He recommended approval of the lowest bid from Duininck, Inc. A motion was made by Council Member Fagerlie to **Adopt Resolution No. 2026-034 awarding the Iverson Park Lift Station Reconstruction Project to Duininck, Inc. in the amount of \$548,673.25.** Council Member Gilbertson seconded the motion, which carried on a roll call vote of Ayes 6, Noes 0.

Ayes Council Member Ask, Council Member Nelsen, Council Member Gilbertson,  
Council Member Gardner, Council Member Fagerlie, Council Member Davis,  
Council Member Shuldes  
Noes None

Council Member Gilbertson made a motion to **Adopt Resolution No. 2026-035 Approving the as-bid budget for the Iverson Park Lift Station Reconstruction Project in the amount of \$887,749.** Council Member Shuldes seconded the motion, which carried on a roll call vote of Ayes 6, Noes 0.

Ayes Council Member Ask, Council Member Nelsen, Council Member Gilbertson,  
Council Member Gardner, Council Member Fagerlie, Council Member Davis,  
Council Member Shuldes  
Noes None

**C. Approve Plans & Specifications, Authorize Advertisement for Bids Project No. 2601-A 4th St SW Reconstruction**

City Engineer Jared Voge gave a summary of the 4<sup>th</sup> Street SW Reconstruction project plans and specifications. Council Member Shuldes moved to **Adopt Resolution No. 2026-036 Approving Plans and Specifications and Authorizing Advertisement for Bids on Project No. 2601-A 4th Street SW Reconstruction.** Council Member Gilbertson seconded the motion, which carried on a roll call vote of Ayes 7, Noes 0.

Ayes Council Member Ask, Council Member Nelsen, Council Member Gilbertson,  
Council Member Gardner, Council Member Fagerlie, Council Member Davis,  
Council Member Shuldes  
Noes None

**D. Purchase & Replacement of Public Works Plow Truck**

Public Works Director Shane Stefanick detailed the need for a replacement of a current dump truck with snow removal equipment. It was noted that there is a need to budget for replacement of dump trucks at a rate of one per year based on their life expectancy. A motion was made by Council Member Gardner to **Adopt Resolution No. 2026-037 Approving the Purchase and Replacement of a 2027 International HV507 dump truck in the amount of \$119,915.02 plus tax and license, and snow removal equipment in the amount of \$177,590.00; for a total of \$297,505.02.** Council Member Gilbertson seconded the motion, which carried on a roll call vote of Ayes 7, Noes 0.

Ayes Council Member Ask, Council Member Nelsen, Council Member Gilbertson,  
Council Member Gardner, Council Member Fagerlie, Council Member Davis,

Council Member Shuldes

Noes None

**E. Wastewater Professional Services Agreement with Donohue & Associates, Inc.**

Public Works Director Shane Stefanick provided an overview of the professional services agreement with Donohue and Associates, Inc. for the Jennie-O Turkey Store Nutrient Removal Project. Council Member Fagerlie moved to **Adopt Resolution No. 2026-038 entering into a Professional Services Agreement with Donohue and Associates, Inc. for the Jennie-O Turkey Store (JOTS) Nutrient Removal Project in the amount of \$99,755.** Council Member Shuldes seconded the motion, which carried on a roll call vote of Ayes 7, Noes 0.

Ayes Council Member Ask, Council Member Nelsen, Council Member Gilbertson, Council Member Gardner, Council Member Fagerlie, Council Member Davis, Council Member Shuldes

Noes None

**F. Approval of Bare Land Lease Agreement with Willmar RC Association Approve the lease of land and concept of the Remote Control Park.**

Planning and Development Director Christopher Corbett gave details of the proposed location and lease agreement with Willmar RC Association for an RC Park. Council Member Shuldes moved for **Approval of the Bare Land Lease Agreement with Willmar RC Association.** Council Member Fagerlie seconded the motion, which carried on a roll call vote of Ayes 7, Noes 0.

Ayes Council Member Ask, Council Member Nelsen, Council Member Gilbertson, Council Member Gardner, Council Member Fagerlie, Council Member Davis, Council Member Shuldes

Noes None

**G. License Agreement with City Line Towing Sales and Service, Inc.**

City Attorney Robert Scott outlined the proposed License Agreement with City Line Towing and Sales and Services, Inc. Council Member Fagerlie made a motion to Approve the **License Agreement with City Line Towing Sales and Service, Inc.** Council Member Ask seconded the motion, which carried on a roll call vote of Ayes 5, Noes 2.

Ayes Council Member Shuldes, Council Member Fagerlie, Council Member, Council Member Ask, Council Member Gardner, Council Member Gilbertson

Noes Council Member Davis, Council Member Nelsen

**H. Willmar Connect Phase 1 Construction Services Amendment No. 2**

Operations Director Kyle Box requested approval of Amendment No. 2 for the Willmar Connect Phase I fiber network project. After a lengthy discussion regarding the cost of the project, Council Member Davis made a motion to **Adopt Resolution No. 2026-039 Accepting Amendment No. 2 to the Professional Services Agreement with Bolton & Menk, Inc. for construction services for the Willmar Connect Phase I fiber network project in the amount of \$520,393.** Council Member Shuldes seconded the motion, which carried on a roll call vote of Ayes 5, Noes 2.

Ayes Council Member Ask, Council Member Nelsen, Council Member Gilbertson, Council Member Davis, Council Member Shuldes

Noes Council Member Gardner, Council Member Fagerlie

I. **Willmar Connect Phase 1 Professional Services with Hometown Fiber**

Operations Director Kyle Box requested approval to enter into a professional service agreement with Hometown Fiber. Council Member Gilbertson moved to **Approve Resolution No. 2026-040 Executing a Professional Services Agreement with Hometown Fiber for construction oversight, technical consulting, and Network Operations Center (NOC) planning services for the Willmar Connect Phase 1 fiber network project.** Council Member Shuldes seconded the motion, which carried on a roll call vote of Ayes 5, Noes 2.

Ayes Council Member Ask, Council Member Nelsen, Council Member Gilbertson,  
Council Member Davis, Council Member Shuldes

Noes Council Member Gardner, Council Member Fagerlie

**ANNOUNCEMENTS**

Mayor Reese shared that City Administrator Leslie Valiant announced her retirement effective January 8, 2027. He went on to thank her for her years of service and for providing the City Council with advanced notice, allowing them adequate time to establish a process for selecting the City’s next City Administrator and ensuring a smooth leadership transition.

Mayor Reese requested that the City Council designate city administrator transition designees to review and consider information relevant to the transition on an Ad Hoc basis and called for a motion to approve the Ad Hoc committee City Administrator transition designees, assigning Justin Ask, Tom Gilbertson, Vicki Davis and himself, Mayor Reese to the committee. Council Member Fagerlie motioned and Council Member Shuldes seconded the motion, which carried on a roll call vote of Ayes 7, Noes 0.

Ayes Council Member Ask, Council Member Nelsen, Council Member Gilbertson, Council  
Member Gardner, Council Member Fagerlie, Council Member Davis, Council Member  
Shuldes

Noes None

With no further business to discuss, Council Member Fagerlie moved to **Adjourn at 7:43 PM.** Council Member Gilbertson seconded the motion, which carried on a roll call vote of Ayes 7, Noes 0.

Ayes Council Member Ask, Council Member Nelsen, Council Member Gilbertson, Council  
Member Gardner, Council Member Fagerlie, Council Member Davis, Council Member  
Shuldes

Noes None

\_\_\_\_\_  
MAYOR

Attest:

\_\_\_\_\_  
CITY CLERK



Snow Removal Equipment Acquisition for the City of Willmar;

NOW THEREFORE BE IT RESOLVED by the City Council of the City of Willmar that:

Final plans and specifications are hereby approved, and publication of the advertisement for bids is herewith authorized. Bid packages will be publicly opened and read at the City Office Building, 333 Southwest Sixth Street, Willmar, Minnesota.

Dated this 16<sup>th</sup> day of March, 2026

/S/ Douglas E. Reese

Mayor

Attest:

/S/Vernae Larsen

City Clerk

CITY OF WILLMAR  
RESOLUTION NO. 2026-028

**APPROVING LABOR AGREEMENT AND MEMORANDUMS OF UNDERSTANDING  
BETWEEN THE CITY OF WILLMAR AND AFSCME PUBLIC WORKS UNIT**

WHEREAS, AFSCME Public Works Unit. is the exclusive representative for certain City of Willmar employees;

WHEREAS, the current labor agreement between the City of Willmar and AFSCME Public Works Unit expired on December 31, 2025;

WHEREAS, the City of Willmar and AFSCME Public Works Unit met and negotiated over the terms of the new labor agreement and memorandums of understanding for city health insurance contributions for 2026 and employee anniversary steps, respectively, between the parties;

WHEREAS, the parties reached a tentative agreement on the terms of the new labor agreement and memorandums of understanding; and

WHEREAS, the Public Employment Relations Act requires that the City of Willmar execute a labor agreement and memorandums of understanding and implement them in the form of a resolution.

NOW, THEREFORE, BE IT RESOLVED by the City Council of Willmar as follows:

1. The Labor Agreement between City of Willmar and AFSCME Public Works Unit for January 1, 2026 through December 31, 2028, which is attached hereto and incorporated herein by reference in its entirety, is approved.
2. The Memorandums of Understanding between City of Willmar and AFSCME Public Works Unit, which are attached hereto and incorporated herein by reference in their entirety, are approved.
3. The Mayor and City Administrator must execute the agreement and memorandums of

understanding.

4. The City of Willmar must implement the agreement and memorandums of understanding.

Voting in Favor: Council Member Ask, Council Member Nelsen, Council Member Gilbertson, Council Member Gardner, Council Member Fagerlie, Council Member Davis, Council Member Shuldes

Voting Against: None

Resolution duly seconded and passed this 16<sup>th</sup> day of March 2026

/S/Vernae Larsen  
City Clerk

/S/ Douglas E. Reese  
Mayor

**Resolution No. 2026-029**

**A RESOLUTION APPROVING THE ADVERTISING AGREEMENT WITH THE WILLMAR SOFTBALL ASSOCIATION FOR ADVERTISING RIGHTS AT THE WILLMAR CIVIC CENTER SOFTBALL FIELDS**

Motion By: Gilbertson Second By: Shuldes

BE IT RESOLVED by the City Council of the City of Willmar, a Municipal Corporation of the State of Minnesota, that the Mayor and City Administrator of the City of Willmar are hereby authorized to approve the agreement with the Willmar Softball Association for advertising rights at the Willmar Civic Center Softball Fields.

Dated this 16<sup>th</sup> Day of March, 2026

/S/ Douglas E. Reese  
Mayor

Attest:

/S/Vernae Larsen  
City Clerk

**Resolution No. 2026-030**

**A RESOLUTION APPROVING THE ADVERTISING AGREEMENT WITH THE WILLMAR HIGH SCHOOL SOFTBALL BOOSTERS FOR ADVERTISING RIGHTS AT THE WILLMAR CIVIC CENTER SOFTBALL FIELDS**

Motion By: Gilbertson Second By: Shuldes

BE IT RESOLVED by the City Council of the City of Willmar, a Municipal Corporation of the State of Minnesota, that the Mayor and City Administrator of the City of Willmar are hereby authorized to approve the agreement with the Willmar High School Softball Boosters for advertising rights at the Willmar Civic Center Softball Fields.

Dated this 16<sup>th</sup> Day of March, 2026

/S/ Douglas E. Reese

\_\_\_\_\_  
Mayor

Attest:

/S/Vernae Larsen

City Clerk

**RESOLUTION NO. 2026-031**

**RESOLUTION APPROVING THE CONCESSION STAND AGREEMENT WITH THE WILLMAR HIGH SCHOOL  
SOFTBALL BOOSTERS**

Motion By: Gilbertson      Second By: Shuldes

BE IT RESOLVED by the City Council of the City of Willmar to approve the concession stand agreement with the Willmar High School Softball Boosters.

Dated this 16<sup>th</sup> day of March, 2026

/S/ Douglas E. Reese

Douglas E. Reese, Mayor

Attest:

/S/Vernae Larsen

CITY CLERK

**RESOLUTION NO. 2026-032**

**RESOLUTION APPROVING THE CONCESSION STAND AGREEMENT WITH THE WILLMAR SOFTBALL  
ASSOCIATION**

Motion By: Gilbertson      Second By: Shuldes

BE IT RESOLVED by the City Council of the City of Willmar to approve the concession stand agreement with the Willmar Softball Association.

Dated this 16<sup>th</sup> day of March, 2026

/S/ Douglas E. Reese

Douglas E. Reese, Mayor

Attest:

/S/Vernae Larsen

CITY CLERK

**RESOLUTION NO. 2026-033**

**RESOLUTION APPROVING TO ADOPT A RESOLUTION ACCEPTING THE PROPOSAL FROM THE JAMAR**

**COMPANY FOR THE REPLACEMENT OF THE BLUE LINE ARENA**

Motion By: Fagerlie Second By: Gilbertson

BE IT RESOLVED by the City Council of the City of Willmar to adopt a resolution accepting the proposal from The Jamar Company for the replacement of the Blue Line Arena roof in the amount of \$263,797.

Dated this 16th day of March 2026

/S/ Douglas E. Reese  
Douglas E. Reese, Mayor

Attest:

/S/Vernae Larsen  
CITY CLERK

**Resolution No. 2026-034**

**A RESOLUTION AWARDING THE IVERSON PARK LIFT STATION RECONSTRUCTION PROJECT TO DUININCK, INC. IN THE AMOUNT OF \$548,673.25.**

Motion By: Fagerlie Second By: Gilbertson

BE IT RESOLVED by the City Council of the City of Willmar, a Municipal Corporation of the State of Minnesota, that the bid of Duininck, Inc. of Prinsburg, MN for the Iverson Park Lift Station Reconstruction Project is accepted, and be it further resolved that the Mayor and City Administrator of the City of Willmar are hereby authorized to enter into an agreement with the bidder for the terms and consideration of the contract in the amount of \$548,673.25 .

Dated this 16<sup>th</sup> day of March, 2026

/S/ Douglas E. Reese  
Mayor

Attest:

/S/Vernae Larsen  
City Clerk

**RESOLUTION NO. 2026-035  
IVERSON PARK LIFT STATION RECONSTRUCTION AS-BID BUDGET  
TOTAL COST \$887,749**

\*Budget Amounts are Essential

Motion By: Gilbertson Second By: Shuldes

Code

**PERSONNEL SERVICES**

- 10\* Salaries Reg. Employees
- 11\* Overtime Reg. Employees
- 12\* Salaries Temp. Employees
- 13\* Employer Pension Contr.

**RECEIVABLES**

- Assessments Prop Owners \$0
- Community Investment/Levy \$0
- MSA \$0
- MUC \$0

14* Employer Ins. Contr.		WTP	\$887,748.25
<b>TOTAL</b>	<b>\$0.00</b>	LOST	\$0

**TOTAL \$887,748.25**

**SUPPLIES**

20* Office Supplies	
21* Small Tools	
22* Motor Fuels & Lubricants	
23* Postage	
24 Mtce. of Equipment	
25 Mtce. of Structures	
26 Mtce. of Other Improvements	
27 Subsistence of Persons	
28 Cleaning & Waste Removal	
29* General Supplies	
<b>TOTAL</b>	<b>\$0.00</b>

**FINANCING**

GENERAL	\$0
LOST	\$0
MSA	\$0
WTP	\$887,748.25
MUC	\$0

**TOTAL \$887,748.25**

**GRAND TOTAL \$887,748.25**

Dated this 16<sup>th</sup> day of March, 2026

**OTHER SERVICES**

33* Travel-Conf.-Schools	
34 Mtce. of Equipment	
35 Mtce. of Structures	
36* Mtce. of Other Impr.	\$548,673.25
37 Subsistence of Persons	
38 Cleaning & Waste Removal	
39* Other Services	\$82,000.00
<b>TOTAL</b>	<b>\$630,673.25</b>

\_\_\_\_\_  
/S/ Douglas E. Reese  
Mayor

**Attest:**

\_\_\_\_\_  
/S/Verna Larsen  
City Clerk

**OTHER CHARGES**

46* Prof. Serv.	\$257,075.00
49 Other Charges	
<b>TOTAL</b>	<b>\$257,075.00</b>
<b>GRAND TOTAL</b>	<b>\$887,748.25</b>

**RESOLUTION NO. 2026-036**

**A RESOLUTION APPROVING FINAL PLANS AND SPECIFICATIONS AND AUTHORIZING PUBLICATION OF THE ADVERTISEMENT FOR BIDS FOR PROJECT NO. 2601-A.**

Motion By: Shuldes Second By: Gilbertson

WHEREAS the City Engineer of the City of Willmar has presented to the City Council plans and specifications for Project No. 2601-A Reconstruction for the City of Willmar;

NOW THEREFORE BE IT RESOLVED by the City Council of the City of Willmar that:

Final plans and specifications are hereby approved, and publication of the advertisement for bids is herewith authorized. Bid packages will be publicly opened and read at the City Office Building, 333 Southwest Sixth Street, Willmar, Minnesota.

Dated this 16<sup>th</sup> day of March, 2026

\_\_\_\_\_  
/S/ Douglas E. Reese  
Mayor

Attest:

\_\_\_\_\_  
/S/Vernae Larsen  
City Clerk

**RESOLUTION NO. 2026-037**

**A RESOLUTION APPROVING THE PURCHASE OF A 2027 INTERNATIONAL DUMP TRUCK WITH SNOW REMOVAL EQUIPMENT IN THE AMOUNT OF \$297,505.02.**

Motion By: Gardner      Second By: Gilbertson

BE IT RESOLVED by the City Council of the City of Willmar, a Municipal Corporation of the State of Minnesota, the purchase of a 2027 International HV507 dump truck from North Central International of St. Cloud, LLC is accepted through State Contract No. 242589 in the amount of \$119,915.02, and snow removal equipment from Towmaster Truck Equipment, LLC through State Contract No. 267372 in the amount of \$177,590, and be it further resolved the Mayor and City Administrator of the City of Willmar are hereby authorized to enter into an agreement with the bidders for the terms and consideration of the contract in the total amount of \$297,505.02 with tax and license paid at a later date.

Dated this 16th day of March, 2026

\_\_\_\_\_  
/S/ Douglas E. Reese  
Mayor

Attest:

\_\_\_\_\_  
/S/Vernae Larsen  
City Clerk

**Resolution No. 2026-038**

**A RESOLUTION AWARDING THE WASTEWATER INDUSTRIAL BNR PROJECT PROFESSIONAL SERVICES TO DONOHUE & ASSOCIATES, INC. IN THE AMOUNT OF \$99,755.**

Motion By: Fagerlie      Second By: Gilbertson

BE IT RESOLVED by the City Council of the City of Willmar. A Municipal Corporation of the State of Minnesota, that the bid of Donohue & Associates, Inc. for the Industrial BNR Project professional services is accepted, and be it further resolved that the Mayor and City Administrator of the City of Willmar are hereby authorized to enter into an agreement with the bidder for the terms and consideration of the contract in the amount of \$99,755.

Dated this 16<sup>TH</sup> day of March, 2026

\_\_\_\_\_  
/S/ Douglas E. Reese  
Mayor

Attest:

\_\_\_\_\_  
/S/Vernae Larsen  
City Clerk

**RESOLUTION NO. 2026-039**

**A RESOLUTION AUTHORIZING THE CITY OF WILLMAR TO ENTER INTO A PROFESSIONAL SERVICES CONTRACT WITH BOLTON & MENK - AMENDMENT NO. 2**

Motion By:     Davis    

Second By:     Shuldes    

Whereas, the City Council of the City of Willmar, Minnesota, entered into a professional services contract with Bolton and Menk, Inc., on October 7, 2024, for the City of Willmar Proposed Phase 1 Fiber Infrastructure Project.

Whereas, the City Council of the City of Willmar, Minnesota, amended the professional services contract with Bolton and Menk, Inc., on April 21, 2025, to assist with right-of-way easements in specific areas within the project area.

Whereas, the City Council of the City of Willmar, Minnesota, has approved the bids for construction of Willmar Connect Phase 1 and requests that construction services be provided by Bolton and Menk for Willmar Connect Phase 1.

BE IT RESOLVED by the City Council of the City of Willmar, Minnesota, to authorize the Mayor and the City Administrator to enter into an Amended Professional Services Agreement with Bolton & Menk, Inc., for the Willmar Connect Phase 1 Fiber Infrastructure Project in the amount not to exceed \$520,393.

Dated this 16<sup>th</sup> day of March 2026

    /S/ Douglas E. Reese      
MAYOR

Attest:

    /S/Vernae Larsen      
CITY CLERK

**RESOLUTION NO. 2026-040**

**A RESOLUTION AUTHORIZING THE CITY OF WILLMAR TO ENTER INTO A PROFESSIONAL SERVICES CONTRACT WITH HOMETOWN FIBER**

Motion By:     Gilbertson    

Second By:     Shuldes    

Whereas, the City Council of the City of Willmar, Minnesota, has approved the bids for construction of Willmar Connect Phase 1 and requests that technical construction services be provided by Hometown Fiber for Willmar Connect Phase 1 and the Network Operation Center.

BE IT RESOLVED by the City Council of the City of Willmar, Minnesota, to authorize the Mayor and the City Administrator to enter into a Professional Services Agreement with Hometown Fiber for the Willmar Connect Phase 1 Fiber Infrastructure Project in the amount not to exceed \$400,000.

Dated this 16<sup>th</sup> day of March 2026

    /S/ Douglas E. Reese      
MAYOR

Attest:

    /S/Vernae Larsen      
CITY CLERK

**PARKS AND RECREATION BOARD**  
**November 19, 2025, 1:30PM**  
**Willmar Civic Center-Community Room**

Members Present: Steve Tammen, Al Setrum, Doug Doering, Jeff Newberg  
Alissa Norsten, Stephanie Carlson

Staff Present: Rob Baumgarn, Rachel Centellas, Curt Hein, Kevin Strey,  
Anita Nelson

Council Members Present: Carl Shuldes, Steve Gardner

Jeff called the meeting to order and took roll call. He asked for any additions or deletions to the agenda, there were none.

Jeff asked for a motion to approve the September meeting minutes. Steve made a motion, Stephanie seconded. All were in favor. September meeting minutes approved.

There were no public comments.

The first item on the agenda was the 2026 fee schedule. Rob discussed the fees from last year for the department and discussed with the board about any increases that should be made. The board agreed all shelter rental fees should go up \$5. Discussion took place on the aquatic center fees, gym rentals, and the Civic Center. The board also talked about any fees for the outdoor rink. Stephanie made a motion to approve increasing shelter rental fees by \$5, Steve seconded. All were in favor, motion approved.

The next item for discussion was the Willmar skate park. A group had approached Rob about naming rights for the skate park. Rob discussed how the City is currently working with a company for naming rights as a possible revenue source. Discussion took place.

Rob talked about how there has been some controversy with pickleball at the REC center. Some people bring their children and it creates a safety hazard. A schedule has been put in place for adult only time, but that is not always followed. There have been complaints from other participants and staff is trying to figure out the best way to address their concerns. Discussion took place on pickleball programming.

The next item for discussion was the advertisement and concession stand agreements for the Civic Center baseball/softball complex. Currently the Velocity softball group has the rights, but the High School softball association would like to take this over. They would take over the concession stand and rights for banners for 2 of the fields, and Velocity would keep 2 fields. Discussion took place on the agreement.

For board recruitment Steve has accepted his second term and will be coming back.

Kevin discussed his programs that are currently running and gave an update on more winter program planning.

There were no board announcements.

Stephanie made a motion to adjourn the meeting, Steve seconded. All were in favor.  
Meeting adjourned.

The Willmar Municipal Utilities Commission met on Monday, March 23, 2026, at 11:45 a.m. in the WMU Auditorium. Commissioners present were President Shawn Mueske, Steve Ammerman, Carol Laumer, Patricia Elizondo, and John Kennedy. Commissioner Brad Michelson was absent.

Staff present included Director of Administration Janell Johnson; Finance and Office Services Supervisor Andrea Prekker; Information Systems Coordinator Mike Sangren; Executive Secretary Abby Ahrendt; and City Council Liaison Tom Gilbertson. Additional attendees included City Attorney Robert Scott (via teleconference) and Jennifer Kotila of the *West Central Tribune*. General Manager Jeron Smith was absent.

President Mueske called the meeting to order, followed by the Pledge of Allegiance. With no requested changes to the agenda, President Mueske proceeded to the Consent Agenda. Director of Administration Johnson highlighted items related to the payment of bills. Following review, Commissioner Ammerman made a motion, seconded by Commissioner Elizondo, to adopt **Resolution No. 12**, which carried by roll call vote of five ayes and zero noes.

Janel Bitzan, CPA, from BerganKDV presented the 2025 Audit Presentation. Bitzan reported that the audit resulted in an unmodified opinion, indicating a clean audit with the financial statements fairly represented in all material respects. She noted one internal control finding related to segregation of accounting duties due to staffing limitations, with no compliance findings. Bitzan also provided an overview of the Commission's financial performance and operations for the year. Commissioner Ammerman made a motion, seconded by Commissioner Laumer, to adopt **Resolution No. 13**, which carried by roll call vote of five ayes and zero noes.

Director of Administration Johnson presented a request to change the consultant from the 2026 Approved Consultant Listing for the 2027-29 Water Rate Study. Johnson was notified that due to time commitments, the proposed consultant is unable to complete the study in a timely manner. It is requested to reassign the task to Dave Berg Consulting to complete the 3-year study within the budgeted allocation. Following discussion, Commissioner Laumer made a motion, seconded by Commissioner Kennedy, to approve consultant change to Dave Berg Consulting for the 2027-29 Water Rate Study, which carried by roll call vote of five ayes and zero noes.

Director of Administration Johnson announced that Willmar Municipal Utilities received the 2025 Minnesota Safety Council Governors Workplace Safety Award, Silver Achievement, which will be presented in May.

**Upcoming Events:**

- ❖ Joint Council and Commission Work Session – April 13, 2026 | 1:00 – 4:00 p.m. | Heritage Bank
- ❖ Employee Recognition Staff Luncheon – April 14, 2026 | 12:00 – 1:00 p.m. | WMU Auditorium
- ❖ MRES Annual Meeting – May 6-7, 2026 | Sioux Falls Convention Center, Sioux Falls, SD
- ❖ APPA 2026 National Conference – June 26-July 1, 2026 | Boston, Massachusetts
- ❖ MMUA Summer Conference – August 17-19, 2026 | St. Cloud, MN

President Mueske asked for any additional discussion. Hearing none, Commissioner Kennedy moved to adjourn, seconded by Commissioner Ammerman. Motion carried by a 5–0 vote. The meeting adjourned at 12:03 p.m.

Respectfully submitted,  
WILLMAR MUNICIPAL UTILITIES

---

Abby Ahrendt, Executive Secretary

ATTEST:

---

Secretary

**RESOLUTION NO. 12**

BE IT RESOLVED by the Municipal Utilities Commission of the City of Willmar, Minnesota, that the Consent Agenda be approved as presented, including the following:

- ❖ Minutes from the March 9, 2026, MUC Meeting
- ❖ Bills represented by vouchers No. 20260331 through No. 20260390, including associated wire transfers, totaling \$1,668,742.56.

Dated this 23<sup>rd</sup> day of March, 2026.

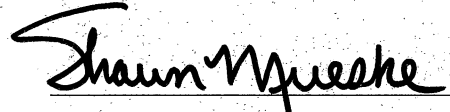
  
President

Attest:

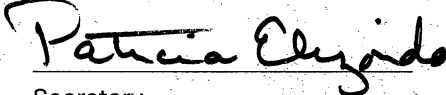
  
Secretary

**RESOLUTION NO. 13**

BE IT RESOLVED that the Willmar Municipal Utilities Commission hereby approves and accepts the 2025 audit for the year ended December 31, 2025, as presented by BerganKDV.

Dated this 23rd day of March, 2026.

\_\_\_\_\_  
President

Attest:

\_\_\_\_\_  
Secretary



### City Council Action Request

<b>Council Meeting Date:</b>	April 6, 2026	<b>Agenda Item Number:</b>	5.D.
<b>Agenda Section:</b>	Consent Items	<b>Originating Department:</b>	Administration
<b>Resolution:</b>	No	<b>Prepared By:</b>	Allie Paulsen, Administrative Assistant
<b>Ordinance:</b>	No	<b>Presented By:</b>	Leslie Valiant, City Administrator
<b>Item:</b>	Willmar Municipal Utilities Commission Applicant		

**RECOMMENDED ACTION:**

Approve Jennie-O representative, Doug Muzik to the Willmar Municipal Utilities Commission.

**OVERVIEW:**

Mayor Reese has approved forwarding Willmar Municipal Utilities Commission applicant Doug Muzik.

**BUDGETARY/FISCAL ISSUES:**

**ALTERNATIVES TO CONSIDER:**

**ATTACHMENTS:**

1. Muzik, Doug Municipal Utilities Commission

# APPLICATION FOR APPOINTMENT TO CITY BOARD/COMMITTEE/COMMISSION ('22)

[Print](#) [Del](#)

**Submitted by:** Doug Muzik

**Submitted On:** 2026-03-02 14:29:32

**Submission IP:** 198.245.13.4, 165.225.56.233 (172.31.22.38)  
proxy-IP (raw-IP)

**Status:** Open

**Priority:** Normal

**Assigned To:** Allie Paulsen

**Due Date:** Open



## APPLICATION FOR APPOINTMENT TO CITY BOARD/COMMITTEE/COMMISSION

333 Southwest 6th Street, Willmar, MN 56201 | 320-235-8311 | Fax: 320-235-4917

Please indicate the Board/Committee(s)/Commission(s) to which you are interested in being appointed. You may select more than one.

\* Please indicate the Board/Committee(s)/Commission(s) to which you are interested in being appointed. You may select more than one.

- Airport Commission (meets monthly)
- Cable Advisory Board (meets as needed)
- Charter Commission (meets as needed)
- Park and Recreation Board
- City/County Economic Development Operations Board (meets monthly)
- Human Rights Commission (meets as needed)
- Municipal Utilities Commission (meets bi-monthly)
- Pioneerland Library System Board (meets monthly)
- Planning Commission (meets bi-monthly)
- Police Civil Service Commission (meets first Monday in February each year and on as-needed basis thereafter)
- Willmar Convention and Visitors Bureau
- Ad hoc Task Forces (will be posted and will meet on an as-needed basis)
- Zoning Appeals Board
- Downtown Willmar (DTW)

If you are currently in this Board/Committee/Commission, are you applying for reappointment to serve another term?

- Yes
- No, I have not served this Board/Committee/Commission

### APPLICANT INFORMATION

Date	* First Name	* Last Name
03/02/2026	Doug	Muzik

Format: MM/DD/YYYY

**\* Address**

1504A LOWER TRENTWOOD CIRCLE N

**\* City**

WILLMAR

---

**\* Phone**

5076020963

Phone

**\* Email**

dlmuzik@j-ots.com

Email

---

**\* What prompted you to make application for a citizen committee?**

I work for Jennie-O Turkey Store. My understanding is that we've had a representative on the Utilities commission for several years and I was asked if I would like to serve now that our current representative, Dave Baumgart, is retiring.

---

**\* Briefly tell us why you want to serve on this Board/Committee/Commission:**

I want to serve on the utility commission because reliable, affordable utilities are essential to our community's quality of life and local economic growth. I'm committed to responsible oversight, long term planning, and making decisions that keep rates fair while maintaining strong infrastructure for the future.

---

**\* List any special background or experience you have which would be helpful to this Board/Committee/Commission:**

Jennie-O Turkey Store/Hormel Foods employee for 24+ years and have worked in several locations and different processing plants.

---

**\* List your educational background**

High school graduate from Detroit Lakes, MN high school in 1997. Attended Concordia College and graduated in 2001 with my bachelors degree in Business.

---

**\* List any social, fraternal, patriotic, governmental, or service organizations, which you have or currently are serving on:**

None

---

**\* If you are employed, please provide the name and address of your employer and your position:**

Jennie-O Turkey Store 2505 Willmar Ave SW Willmar, MN 56201 I am currently the Plant Manager and have held this role since April of 2025.

---



### City Council Action Request

<b>Council Meeting Date:</b>	April 6, 2026	<b>Agenda Item Number:</b>	5.E.
<b>Agenda Section:</b>	Consent Items	<b>Originating Department:</b>	Public Works
<b>Resolution:</b>	Yes	<b>Prepared By:</b>	Kelsi Delbosque, Administrative Assistant
<b>Ordinance:</b>	No	<b>Presented By:</b>	Jared Voge, City Engineer
<b>Item:</b>	Project No. 2608 Seal Coat/Crack Seal Improvements Plans & Specs., Authorize Ad for Bids		

**RECOMMENDED ACTION:**

Adopt the resolution approving plans and specifications and authorizing advertisement for bids on Project No. 2608 Seal Coat and Crack Seal Improvements.

**OVERVIEW:**

Project No. 2608 includes the crack seal and seal coat improvements identified in the attached figure as part of the 2026 street and other improvements. Bids are scheduled to be opened on April 22nd at 1:15 p.m.

**BUDGETARY/FISCAL ISSUES:**

The project is to be funded by the Public Works operating budget.

**ALTERNATIVES TO CONSIDER:**

**ATTACHMENTS:**

1. Resolution- Approve Specs & Adv. For Bids Project No. 2608
2. Project No. 2608 Location Figure

RESOLUTION NO. \_\_\_\_\_

**A RESOLUTION APPROVING FINAL PLANS AND SPECIFICATIONS AND AUTHORIZING  
PUBLICATION OF THE ADVERTISEMENT FOR BIDS FOR PROJECT NO. 2608.**

Motion By: \_\_\_\_\_ Second By: \_\_\_\_\_

WHEREAS the City Engineer of the City of Willmar has presented to the City Council plans and specifications for Project No. 2608 Crack Seal/Seal Coat for the City of Willmar;

NOW THEREFORE BE IT RESOLVED by the City Council of the City of Willmar that:

Final plans and specifications are hereby approved, and publication of the advertisement for bids is herewith authorized. Bid packages will be publicly opened and read at the City Office Building, 333 Southwest Sixth Street, Willmar, Minnesota.

Dated this 6<sup>th</sup> day of April, 2026

\_\_\_\_\_  
Mayor

Attest:

\_\_\_\_\_  
City Clerk

**NOTES:**

1. THE CONTRACTOR SHALL MEET ONSITE WITH THE ENGINEER TO REVIEW ALL STREETS PRIOR TO COMMENCING SEAL COAT OPERATIONS.
2. THE CONTRACTOR SHALL NOTIFY THE ENGINEER, ALL PROPERTY OWNERS, AND BUSINESSES AFFECTED BY THE PROJECT A MINIMUM OF 48 HOURS IN ADVANCE PRIOR TO COMMENCING ANY WORK PERTAINING TO THE PROJECT. ANY WORK COMPLETED WITHOUT FIRST NOTIFYING THE ENGINEER WILL BE CONSIDERED UNAUTHORIZED WORK AND WILL NOT BE PAID.
3. THE CONTRACTOR SHALL BE SOLELY RESPONSIBLE FOR PLACING AND REMOVING "NO PARKING" THROUGHOUT THE PROJECT AREA, WHICH SHALL BE CONSIDERED INCIDENTAL TO CONSTRUCTION.
4. SURPLUS SEAL COAT AGGREGATE IS THE PROPERTY OF THE CONTRACTOR AND THE CONTRACTOR SHALL PROMPTLY REMOVE AND DISPOSE OF IT IN AN APPROPRIATE MANNER.

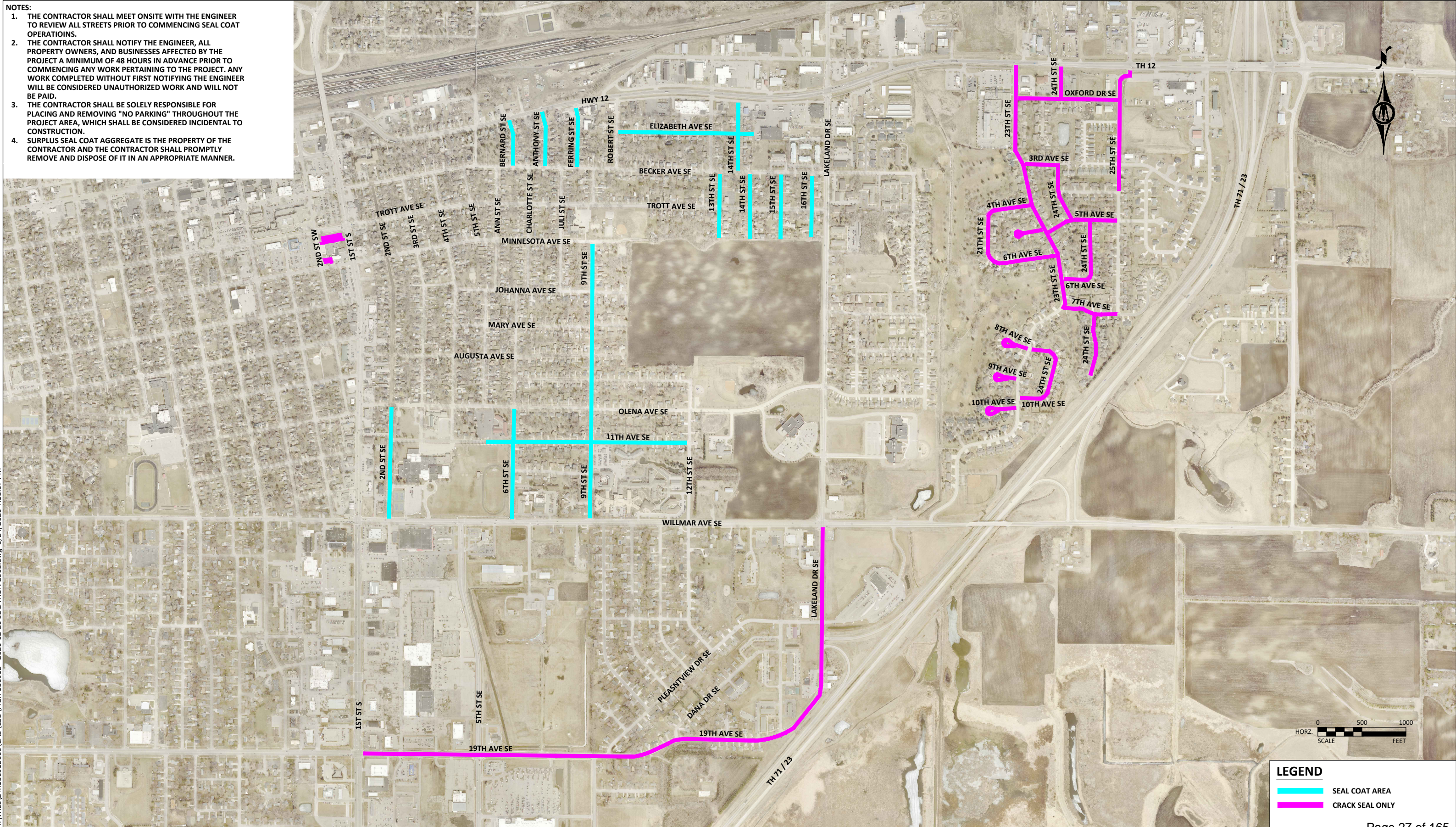

H:\WILL\24X136912000\CAD\C3D\FIGR-136912 - 2026-02-26 LOCATION 2608.dwg 3/24/2026 4:18:57 PM

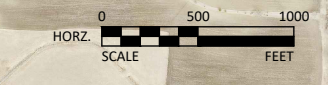

**LEGEND**

<span style="color: cyan;">—</span>	SEAL COAT AREA
<span style="color: magenta;">—</span>	CRACK SEAL ONLY



### City Council Action Request

<b>Council Meeting Date:</b>	April 6, 2026	<b>Agenda Item Number:</b>	5.F.
<b>Agenda Section:</b>	Consent Items	<b>Originating Department:</b>	Public Works
<b>Resolution:</b>	Yes	<b>Prepared By:</b>	Kelsi Delbosque, Administrative Assistant
<b>Ordinance:</b>	No	<b>Presented By:</b>	Jared Voge, City Engineer
<b>Item:</b>	Project No. 2605-B Stormwater Capital Improvements Plans & Specs., Authorize Solicitation of Quotes		

**RECOMMENDED ACTION:**

Adopt the resolution approving plans and specifications for Project No. 2605-B and authorizing solicitation of quotes.

**OVERVIEW:**

Project No. 2605-B includes the stormwater capital improvements identified for construction as part of the City's Storm Sewer Capital Improvement Plan. Hydrodynamic Separator structures (HDS) are proposed to be installed near 23rd St SE and 8th Ave SE to address debris and sediment buildup in the storm sewers. To address the heaved roadway on Gorton Ave NW, the street surface will be repaired and polystyrene insulation installed between the street base material and the storm sewer pipe to reduce differential movement between soils and shallow utilities. A swale and berm will be constructed to address drainage concerns on High Avenue NE. Quotes for the project are scheduled to be due at 4:30 p.m. on April 23rd.

**BUDGETARY/FISCAL ISSUES:**

The project is to be paid from Local Option Sales Tax (LOST) funds.

**ALTERNATIVES TO CONSIDER:**

**ATTACHMENTS:**

1. Resolution- Approve Specs & Sol. for Quotes Project No. 2605-B
2. Project No. 2605-B Title Sheet

**RESOLUTION NO. \_\_\_\_\_**

**A RESOLUTION APPROVING FINAL PLANS AND SPECIFICATIONS AND AUTHORIZING  
PUBLICATION OF THE SOLICITATION FOR QUOTES FOR PROJECT NO. 2605-B.**

Motion By: \_\_\_\_\_ Second By: \_\_\_\_\_

WHEREAS the City Engineer of the City of Willmar has presented to the City Council plans and specifications for Project No. 2605-B Stormwater Capital Improvements for the City of Willmar;

NOW THEREFORE BE IT RESOLVED by the City Council of the City of Willmar that:

Final plans and specifications are hereby approved, and publication of the solicitation of quotes is herewith authorized. Quotes will be received at the City Office Building, 333 Southwest Sixth Street, Willmar, Minnesota.

Dated this 6<sup>th</sup> day of April, 2026

\_\_\_\_\_

Mayor

Attest:

\_\_\_\_\_

City Clerk

# CITY OF WILLMAR

## CONSTRUCTION PLANS FOR

# 2026 STORMWATER CAPITAL IMPROVEMENT PROJECT

SITE GRADING, PAVEMENT PATCHING, CASTING ADJUSTMENT, TURF ESTABLISHMENT  
CONCRETE CURB & GUTTER  
APRIL, 2026

NOTE: EXISTING UTILITY INFORMATION SHOWN ON THIS PLAN HAS BEEN PROVIDED BY THE UTILITY OWNER. THE CONTRACTOR SHALL FIELD VERIFY EXACT LOCATIONS PRIOR TO COMMENCING CONSTRUCTION AS REQUIRED BY STATE LAW. NOTIFY GOPHER STATE ONE CALL, 1-800-252-1166 OR 651-454-0002.

THE SUBSURFACE UTILITY INFORMATION IN THIS PLAN IS UTILITY QUALITY LEVEL "D". THIS UTILITY QUALITY LEVEL WAS DETERMINED ACCORDING TO THE GUIDELINES OF CI/ASCE 38-22, ENTITLED "STANDARD GUIDELINES FOR INVESTIGATING AND DOCUMENTING EXISTING UTILITIES."

MAP OF THE  
CITY OF WILLMAR  
KANDIYOHI COUNTY, MN

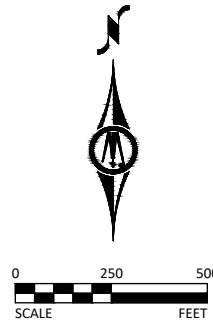

### MAP LEGEND

PROJECT LOCATION

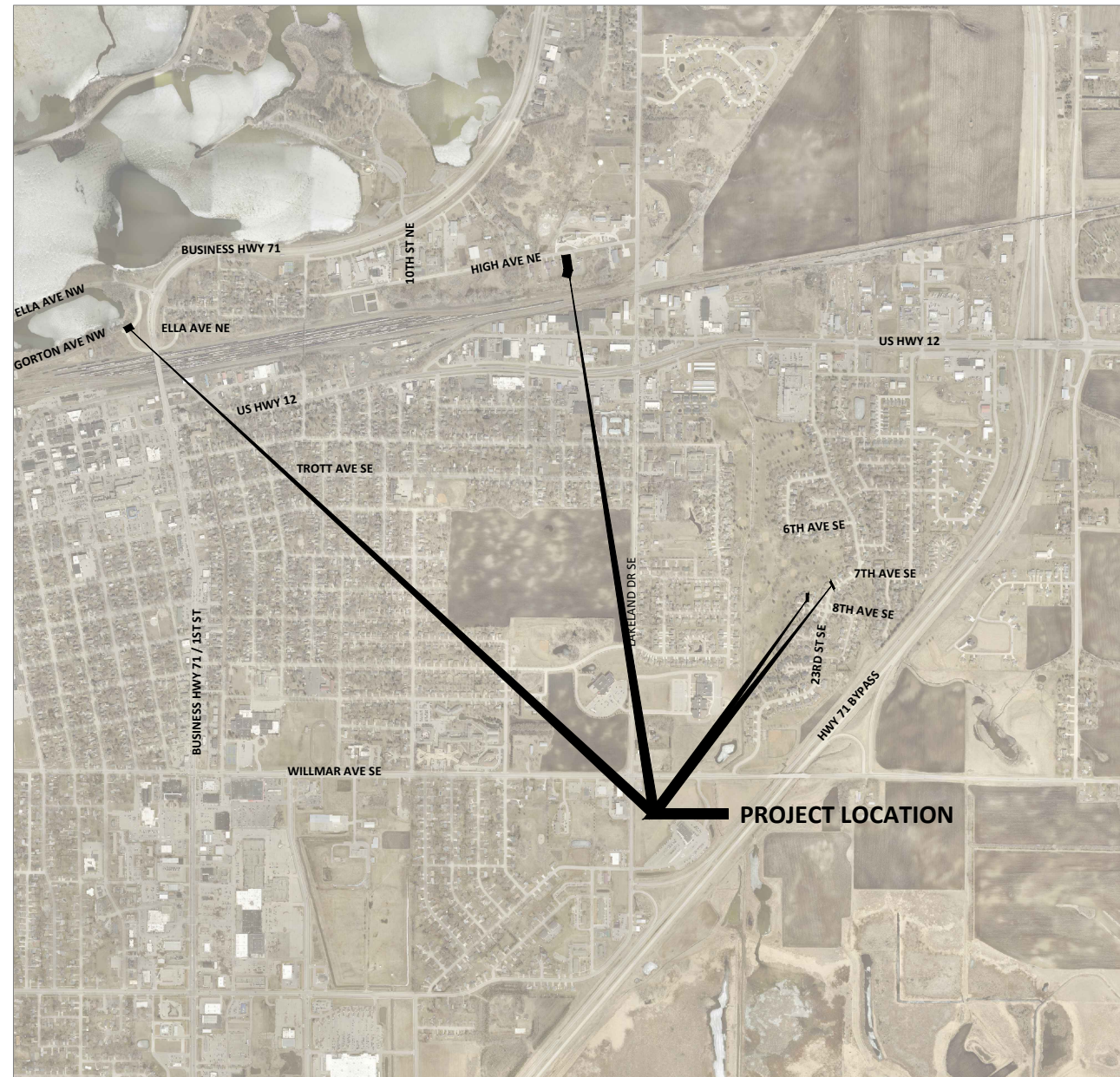

SHEET NUMBER	SHEET TITLE
GENERAL	
G0.01 - G0.03	TITLE SHEET, LEGEND, GENERAL NOTES
G1.01	STATEMENT OF ESTIMATED QUANTITIES
G2.01 - G2.03	LOCATION PLAN
CIVIL	
C0.01 - C0.03	EXISTING CONDITIONS, REMOVALS PLAN
C1.01 - C1.06	TABLES, DETAILS, TYPICAL SECTIONS, PHASING PLAN
C2.01 - C2.03	EROSION CONTROL PLAN, SWPPP
C3.01	GRADING PLAN
C5.01 - C5.03	STORM SEWER PLAN & PROFILE
C6.01 - C6.03	STREET & GRADING PLAN & PROFILE
C7.01 - C7.03	TRAFFIC CONTROL PLAN
C8.01 - C8.02	CROSS SECTIONS

THIS PLAN SET CONTAINS 31 SHEETS.

⚡ BM=XXXX.XX DESCRIPTION STATION LOCATION	PROJECT DATUM:
	HORIZONTAL: VERTICAL:

© Bolton & Menk, Inc. 2026. All Rights Reserved. A:\WILL\252414\252414\_252414\_252414.dwg 3/24/2026 12:47 PM Plotted by: Dalton Lindstrand

I HEREBY CERTIFY THAT THIS PLAN, SPECIFICATION, OR REPORT WAS PREPARED BY ME OR UNDER MY DIRECT SUPERVISION AND THAT I AM A DULY LICENSED PROFESSIONAL ENGINEER UNDER THE LAWS OF THE STATE OF MINNESOTA.

*Joshua J. Halvorson*  
 JOSHUA J. HALVORSON  
 LIC. NO. 46291 DATE 04/06/2026



2040 HIGHWAY 12 EAST  
 WILLMAR, MN 56201  
 Phone: (320) 231-3956  
 Email: Willmar@bolton-menk.com  
 www.bolton-menk.com

DESIGNED	NO.	ISSUED FOR	DATE
SJJ			
DRAWN			
DML			
CHECKED			
SJJ - JJH			
CLIENT PROJ. NO.			
25K-141969 / 2605-B			

CITY OF WILLMAR, MINNESOTA		SHEET
2026 STORMWATER CAPITAL IMPROVEMENT PROJECT		G0.01
TITLE		



### City Council Action Request

<b>Council Meeting Date:</b>	April 6, 2026	<b>Agenda Item Number:</b>	5.G.
<b>Agenda Section:</b>	Consent Items	<b>Originating Department:</b>	Public Works
<b>Resolution:</b>	Yes	<b>Prepared By:</b>	Kelsi Delbosque, Administrative Assistant
<b>Ordinance:</b>	No	<b>Presented By:</b>	Jared Voge, City Engineer
<b>Item:</b>	Business 71 Bridge Maintenance Project Plans & Specs., Authorize Ad for Bids		

**RECOMMENDED ACTION:**

Adopt the resolution approving plans and specifications for the Business 71 Bridge Maintenance Project, and authorizing advertisement for bids.

**OVERVIEW:**

The 1st Street/Business Highway 71 Bridge has been identified as requiring maintenance. Although the bridge remains in generally good condition, routine maintenance is needed to address several emerging deficiencies. The maintenance will consist of end treatment improvements, substandard guardrail replacement, sealing cracks, and repairing joints. Bids are scheduled to be opened on April 22nd at 1:30 p.m.

**BUDGETARY/FISCAL ISSUES:**

The project is to be paid from State Aid funds.

**ALTERNATIVES TO CONSIDER:**

**ATTACHMENTS:**

1. Resolution- Approve Specs & Adv. For Bids Business 71 Bridge Maint. Project
2. Business 71 Bridge Maint Title Sheet

RESOLUTION NO. \_\_\_\_\_

**A RESOLUTION APPROVING FINAL PLANS AND SPECIFICATIONS AND AUTHORIZING PUBLICATION OF THE ADVERTISEMENT FOR BIDS FOR THE BUSINESS 71 BRIDGE MAINTENANCE PROJECT.**

Motion By: \_\_\_\_\_ Second By: \_\_\_\_\_

WHEREAS the City Engineer of the City of Willmar has presented to the City Council plans and specifications for the Business 71 Bridge Maintenance Project for the City of Willmar;

NOW THEREFORE BE IT RESOLVED by the City Council of the City of Willmar that:

Final plans and specifications are hereby approved, and publication of the advertisement for bids is herewith authorized. Bid packages will be publicly opened and read at the City Office Building, 333 Southwest Sixth Street, Willmar, Minnesota.

Dated this 6<sup>th</sup> day of April, 2026

\_\_\_\_\_  
Mayor

Attest:

\_\_\_\_\_  
City Clerk

# MINNESOTA DEPARTMENT OF TRANSPORTATION CITY OF WILLMAR KANDIYOHI COUNTY, MINNESOTA BUSINESS HIGHWAY 71 BRIDGE MAINTENANCE

--- GOVERNING SPECIFICATIONS ---  
THE 2025 EDITION OF THE MINNESOTA DEPARTMENT OF TRANSPORTATION  
"STANDARD SPECIFICATION FOR CONSTRUCTION" SHALL GOVERN.

ALL TRAFFIC CONTROL DEVICES AND SIGNING SHALL CONFORM AND BE INSTALLED IN  
ACCORDANCE WITH THE LATEST "MINNESOTA MANUAL ON UNIFORM TRAFFIC CONTROL DEVICES"  
(MN MUTCD), INCLUDING THE LATEST "FIELD MANUAL" FOR TEMPORARY TRAFFIC CONTROL ZONE  
LAYOUTS.

CONSTRUCTION PLAN FOR: PARTIAL DEPTH REPAIR, CRACK SEAL, RECONSTRUCTION OF EXPANSION JOINT

SAP 175-153-025 LOCATED ON BUSINESS HIGHWAY 71 FROM INTERSECTION OF LITCHFIELD AVE SW TO 500' SOUTH OF ELLA AVE NW (GEOGRAPHICAL DESCRIPTION)

FROM THE NORTHEAST CORNER OF SECTION 15, T119N, R35W TO THE SOUTH LINE OF SECTION 10, T119N, R35W (LEGAL DESCRIPTION)

**BUSINESS HIGHWAY 71 (SAP 175-153-025)**

GROSS LENGTH	985 FEET	0.19 MILES
BRIDGE LENGTH	985 FEET	0.19 MILES
EXCEPTION LENGTH	N/A FEET	N/A MILES
NET LENGTH	985 FEET	0.19 MILES

LENGTH AND DESCRIPTION BASED UPON  
PROPOSED BUSINESS HIGHWAY 71 CENTERLINE

SHEET NUMBER	SHEET TITLE
1	TITLE SHEET
2 - 3	GENERAL PLAN AND ELEVATION
4 - 5	TRANSVERSE SECTION
6	DETAILS
7	TRAFFIC CONTROL

THIS PLAN SET CONTAINS 7 SHEETS.

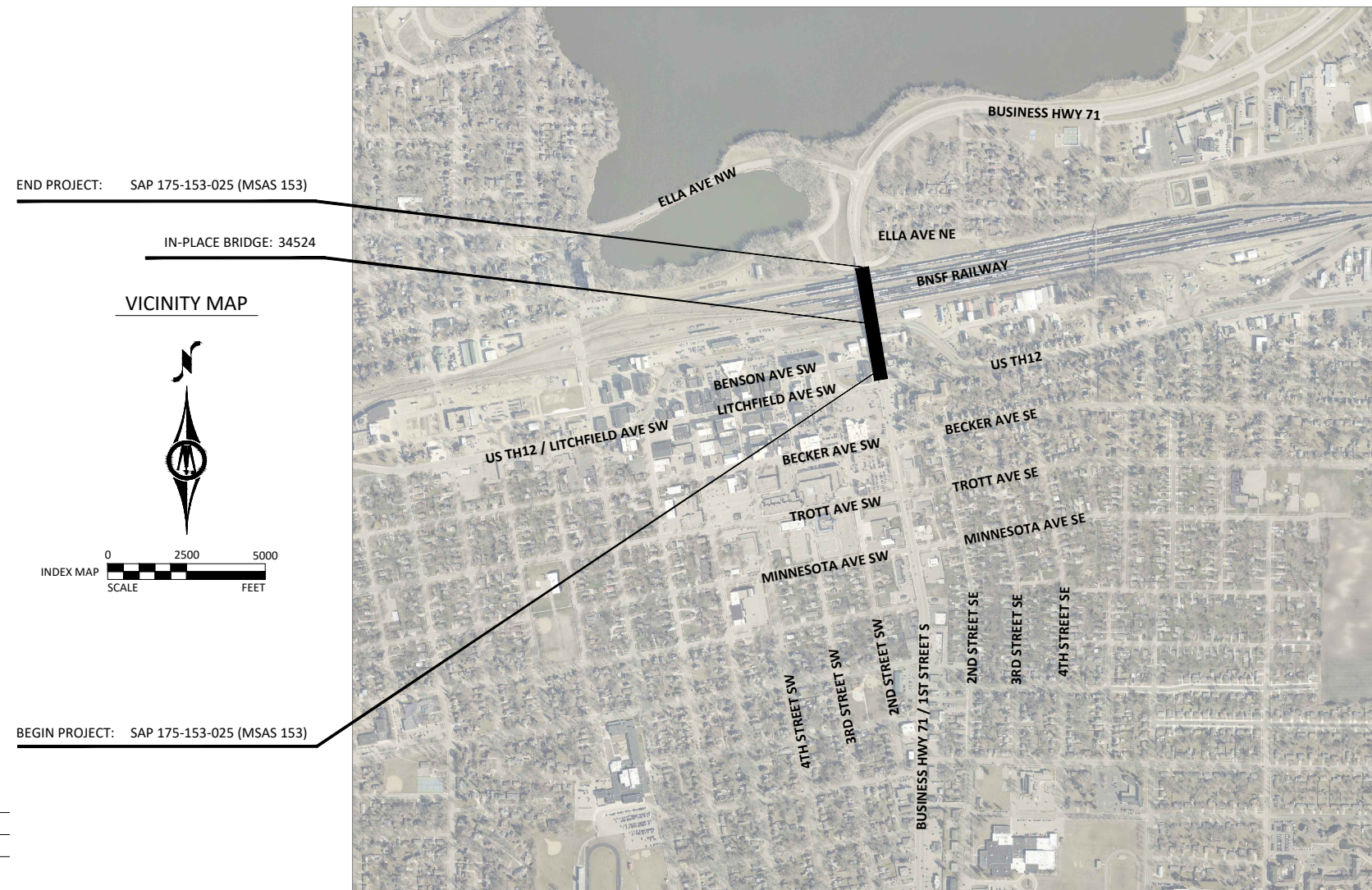

END PROJECT: SAP 175-153-025 (MSAS 153)

IN-PLACE BRIDGE: 34524

**VICINITY MAP**



TYPICAL PLAN SCALE  
UNLESS OTHERWISE NOTED:



**PROJECT LOCATION**

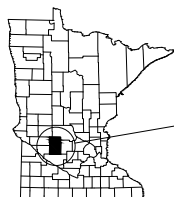

CITY: WILLMAR  
COUNTY: KANDIYOHI  
DISTRICT: 8

BEGIN PROJECT: SAP 175-153-025 (MSAS 153)

THE SUBSURFACE UTILITY INFORMATION IN THIS PLAN IS UTILITY QUALITY LEVEL "D". THIS UTILITY QUALITY LEVEL WAS DETERMINED ACCORDING TO THE GUIDELINES OF C/ASCE 38-22, ENTITLED "STANDARD GUIDELINES FOR INVESTIGATING AND DOCUMENTING EXISTING UTILITIES."

Thomas J. Doherty, P.E.  
Design Engineer: I hereby certify that this plan was prepared by me or under my direct supervision, and that I am a duly Licensed Professional Engineer under the laws of the State of Minnesota.

Date 04/06/2026 License Number 64635

Approved: Date 04/06/2026  
City of Willmar Engineer

District State Aid Engineer:  
Reviewed for compliance with State Aid Rules/Policy

Approved for State Aid Funding: State Aid Engineer



2040 HIGHWAY 12 EAST  
WILLMAR, MN 56201  
Phone: (320) 231-3956  
Email: Willmar@bolton-menk.com  
www.bolton-menk.com

DESIGNED	NO.	ISSUED FOR	DATE
TJD			
DRAWN			
TJD			
CHECKED			
JDA			
CLIENT PROJ. NO.			
25X-141967-000 / 2605-A			

CITY OF WILLMAR, MINNESOTA		SHEET 1 OF 7
1ST STREET BUSINESS HIGHWAY 71 BRIDGE MAINTENANCE PROJECT		
STATE AID PROJECT NO.	175-153-025	



### City Council Action Request

<b>Council Meeting Date:</b>	April 6, 2026	<b>Agenda Item Number:</b>	5.H.
<b>Agenda Section:</b>	Consent Items	<b>Originating Department:</b>	Public Works
<b>Resolution:</b>	Yes	<b>Prepared By:</b>	Kelsi Delbosque, Administrative Assistant
<b>Ordinance:</b>	No	<b>Presented By:</b>	Jared Voge, City Engineer
<b>Item:</b>	TH 40 Turnlane Project Plans & Specs., Authorize Ad for Bids		

**RECOMMENDED ACTION:**

Adopt the resolution approving plans and specifications for the TH 40 Turnlane Project and authorize advertisement for bids.

**OVERVIEW:**

The TH 40 Turnlane project includes the new City road connection to facilitate an anticipated railroad freight facility. The turnlane improvements will allow safe turning movement for heavy freight vehicles on and off TH 40. The bid opening date is to be determined subject to MnDOT approval.

**BUDGETARY/FISCAL ISSUES:**

The funding source for the project is a Transportation Economic Development (TED) grant \$900,000.

**ALTERNATIVES TO CONSIDER:**

**ATTACHMENTS:**

1. Resolution- Approve Specs & Adv. For Bids TH 40 Turnlane Project
2. TH 40 Turnlane Title Sheet

**RESOLUTION NO. \_\_\_\_\_**

**A RESOLUTION APPROVING FINAL PLANS AND SPECIFICATIONS AND AUTHORIZING PUBLICATION OF THE ADVERTISEMENT FOR BIDS FOR THE TH 40 TURNLANE PROJECT.**

Motion By: \_\_\_\_\_ Second By: \_\_\_\_\_

WHEREAS the City Engineer of the City of Willmar has presented to the City Council plans and specifications for the TH 40 Turnlane Project for the City of Willmar;

NOW THEREFORE BE IT RESOLVED by the City Council of the City of Willmar that:

Final plans and specifications are hereby approved, and publication of the advertisement for bids is herewith authorized. Bid packages will be publicly opened and read at the City Office Building, 333 Southwest Sixth Street, Willmar, Minnesota.

Dated this 6<sup>th</sup> day of April, 2026

\_\_\_\_\_

Mayor

Attest:

\_\_\_\_\_

City Clerk

# MINNESOTA DEPARTMENT OF TRANSPORTATION KANDIYOHI COUNTY, CITY OF WILLMAR

CONSTRUCTION PLAN FOR GRADING, BITUMINOUS PAVEMENT & LIGHTING

LOCATED ON TH 40 FROM 1300' EAST OF CSAH 55 TO 1500' WEST OF CSAH 5

STATE PROJ. NO. 3409-23  
GROSS LENGTH 2536 FEET 0.480 MILES  
BRIDGES-LENGTH FEET MILES  
EXCEPTIONS-LENGTH FEET MILES  
NET LENGTH 2536 FEET 0.480 MILES  
REF. POINT 71+00.950 TO REF. POINT 72+00.491

NOTE: LENGTH AND DESCRIPTION BASED ON TH 40 ALIGNMENT

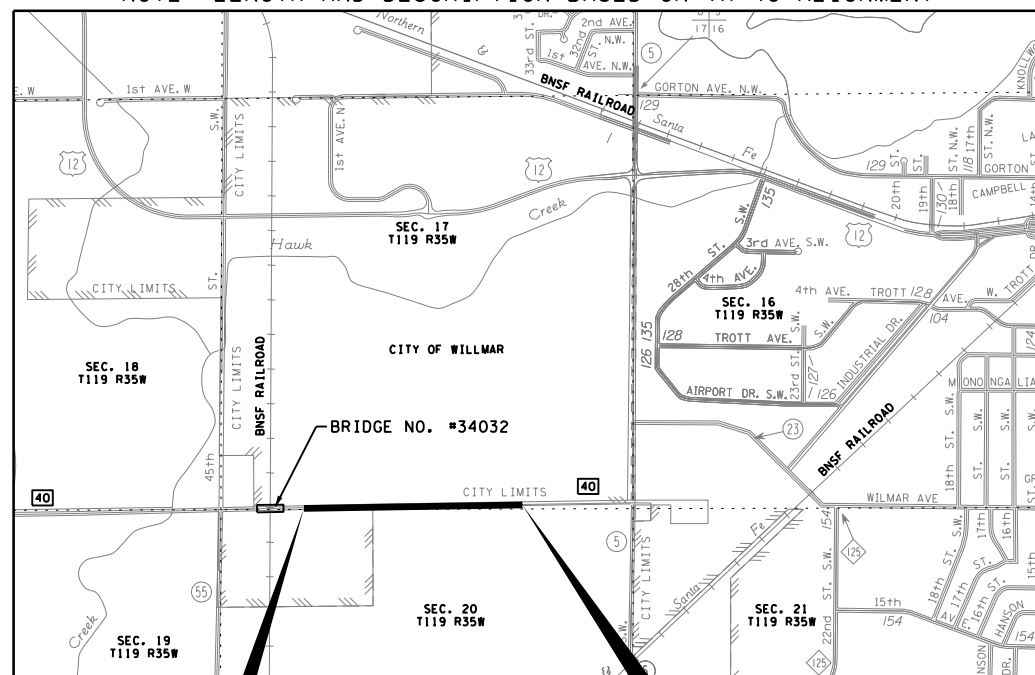

**WARNING:**  
PROJECT CONTAINS HIGH  
PRESSURIZED GAS PIPELINE

BEGIN CONSTRUCTION  
BEGIN S.P. 3409-23  
TH 40  
STA 432+38.00  
R.P. 71+00.950

END CONSTRUCTION  
END S.P. 3409-23  
TH 40  
STA. 457+74.00  
R.P. 72+00.491

AGREEMENT NO. 1061341  
CITY OF WILLMAR  
S.P. 3409-23 (TH 40 = 145)  
STATE FUNDS  
DISTRICT D8

### TH 40 DESIGN DESIGNATION S.P. 3409-23

DESIGN ESALS	2023	=	464,500
ADT (Current Year)	2023	=	1,835
ADT (Future Year) (2043)		=	1,930
Design Strength		=	10-TON
D (Directional Distr.)		=	50/50 %
T (Heavy Commercial)		=	7.2 %
DESIGN SPEED:			60 MPH
BASED ON:			STOPPING SIGHT DISTANCE
HEIGHT OF EYE:	3.5'	HEIGHT OF OBJECT:	2.0'

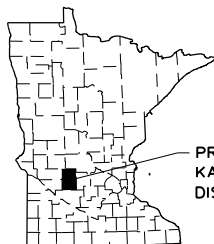

FOR PLANS AND UTILITIES  
SYMBOLS SEE TECHNICAL MANUAL  
STATE PROJ. NO.  
3409-23  
CHARGE IDENTIFIER

CITY OF WILLMAR PROJ. NO. 2505-A

FED. PROJ. NO. STATE FUNDS

GOVERNING SPECIFICATIONS  
THE 2020 EDITION OF THE MINNESOTA DEPARTMENT OF TRANSPORTATION 'STANDARD SPECIFICATIONS FOR CONSTRUCTION' SHALL GOVERN.

ALL TRAFFIC CONTROL DEVICES SHALL CONFORM TO THE MOST RECENT EDITION OF THE 'MINNESOTA MANUAL ON UNIFORM CONTROL DEVICES' (MN MUTCD), INCLUDING 'FIELD MANUAL FOR TEMPORARY TRAFFIC CONTROL ZONE LAYOUTS'.

SHEET NO.	INDEX
1	TITLE SHEET
2	GENERAL LAYOUT
3-4	ESTIMATED QUANTITIES
5	STANDARD PLATES
6	EARTHWORK TABULATIONS & SUMMARY
7	SOILS & CONSTRUCTION NOTES
8-10	TABULATIONS
11-14	TYPICAL SECTIONS
15-18	DESIGN DETAILS
19-37	STANDARD PLANS
38-42	INPLACE TOPOGRAPHY & UTILITY PLAN
43-46	REMOVAL PLAN
47-50	CONSTRUCTION PLAN
51	PROFILES
52-55	CONTOUR PLAN
56-59	DRAINAGE PLAN
60	DRAINAGE PROFILES & TABULATIONS
61-62	ENVIRONMENTAL MANAGEMENT PLAN
63-65	STORMWATER POLLUTION PREVENTION PLAN (SWPPP)
66-69	EROSION CONTROL & TURF ESTABLISHMENT PLAN
70-73	TRAFFIC CONTROL PLAN
74-78	LIGHTING PLAN
79-91	SIGNING & STRIPING PLAN
92	CROSS SECTION MATCHLINE LAYOUT
XS1-XS20	CROSS SECTIONS

THIS PLAN CONTAINS 112 SHEETS



12224 NICOLLET AVENUE  
BURNSVILLE, MINNESOTA 55337  
Phone: (952) 890-0509  
Email: burns@bolton-menk.com  
www.bolton-menk.com

I HEREBY CERTIFY THAT THIS PLAN WAS PREPARED BY ME OR UNDER MY DIRECT SUPERVISION AND THAT I AM A DULY LICENSED PROFESSIONAL ENGINEER UNDER THE LAWS OF THE STATE OF MINNESOTA.

PRINT NAME: DEREK J ARENS LICENSE # 52673

DATE: 03-09-2026 SIGNATURE:

OFFICE OF LAND MANAGEMENT APPROVAL DIRECTOR, LAND MANAGEMENT 20

APPROVED 20 STATE DESIGN ENGINEER

CITY OF WILLMAR PROJ. NO. 2505-A S.P. NO. 3409-23 (TH 40 = 145) SHEET NO. 1 OF 92

nolan.shanahan pdf-B and W.pltcfgr 3/9/2026  
 H:\WILL\0W1131141\CAD\MS\plans\Misc\cd340923\_1001.sth.dgn

PLAN REVISIONS		
DATE	SHEET NO.	APPROVED BY

INDEX MAP	0'	1500'
GENERAL LAYOUT	0'	150'
PLAN	0'	25'
PROFILE	0'	HORIZ. 25'
	0'	VERT. 5'
CROSS-SECTION	0'	HORIZ. 10'
	0'	VERT. 10'



## City Council Action Request

<b>Council Meeting Date:</b>	April 6, 2026	<b>Agenda Item Number:</b>	5.I.
<b>Agenda Section:</b>	Consent Items	<b>Originating Department:</b>	Recreation
<b>Resolution:</b>	Yes	<b>Prepared By:</b>	Rob Baumgarn, Recreation Director
<b>Ordinance:</b>	No	<b>Presented By:</b>	Kyle Box, City Operations Director
<b>Item:</b>	Subaward Agreement with the Connected Communities Project — Bethesda Foundation		

**RECOMMENDED ACTION:**

Adopt a resolution approving an agreement with the Bethesda Foundation as part of the LeadingAge Minnesota Connected Communities initiative in the amount of \$25,240.

**OVERVIEW:**

Bethesda Foundation has been awarded a grant through Leading Age Minnesota as part of the Connected Communities initiative, which supports rural communities in helping older adults age well. The grant runs through May 28, 2027, and focuses on reducing isolation, strengthening community connections, improving access to services, and developing culturally responsive outreach to better engage diverse populations. This effort builds on a statewide model designed to address gaps in the coordination of physical, social, and emotional support for aging residents in rural areas.

The Bethesda Foundation reached out to City staff regarding this opportunity, and through this partnership, the Willmar Community Center will receive \$25,240 in one-time funding as a subaward to support both expanded and existing senior programming. Funds will be used for activities such as senior trips, entertainment, and program staffing—enhancing current offerings without creating ongoing obligations. The intent is to provide meaningful, accessible experiences that many seniors may not otherwise pursue independently, while strengthening community connections and increasing engagement among older adults.

**BUDGETARY/FISCAL ISSUES:**

Funding will come from the Bethesda Foundation as part of the Leading Age Minnesota-Connected Community initiatives (\$25,240).

**ALTERNATIVES TO CONSIDER:**

Don't approve the agreement.

**ATTACHMENTS:**

1. Resolution for Bethesda Connected Communities Initiative
2. WCC - CC sub-agreement - April 2 2026

**RESOLUTION NO. \_\_\_\_**

**RESOLUTION APPROVING AN AGREEMENT WITH THE BETHESDA FOUNDATION AS PART OF THE  
LEADINGAGE MINNESOTA CONNECTED COMMUNITIES INITIATIVE**

Motion By: \_\_\_\_\_ Second By: \_\_\_\_\_

BE IT RESOLVED by the City Council of the City of Willmar to adopt a resolution approving an agreement with the Bethesda Foundation as part of the LeadingAge Minnesota Connected Communities initiative in the amount of \$25,240.

Dated this 6th day of April 2026

\_\_\_\_\_  
Douglas E. Reese, Mayor

Attest:

\_\_\_\_\_  
CITY CLERK

## **SUBAWARD AGREEMENT**

*Between*

**The Connected Communities Project**

*and*

**The City of Willmar**

This is a Subaward agreement between the Connected Communities Project (CC) under the Bethesda Foundation of Willmar, a 501(c)(3) non-profit organization located at 901 Willmar Ave., SE, Willmar, MN, 56201, and the City of Willmar (“Sub-grantee”) through the Willmar Community Center, a multifaceted facility providing social, educational, and recreational services with a special focus on connecting generations, located at 624 US-71 BUS, Willmar, Minnesota 56201. The total project cost of this Subaward will not exceed **\$25,240** without prior written authorization from CC.

### **1. PURPOSE OF THE SUB-GRANT**

- 1.1. The purpose, goals and objectives of this award (“Sub-grant”) to the Sub-grantee is to fund programs and events for seniors in the Community of Willmar. The programs and events include, but are not limited to, entertainment events, bus trips to locations and events of interest by the aging community, trips to local restaurants, motivational speakers, and speakers on topics of interest, recurring social activities, and physical games and exercise programs.
- 1.2. This Sub-grant is issued to the Sub-grantee on the expressed condition that project activities and funds will be carried-out and administered in accordance with the terms and conditions as hereby set forth in this agreement and all its attachments. All attachments and appendices are incorporated herein and made a part of this Sub-grant Agreement.

### **2. PERIOD OF SUB-GRANT AGREEMENT**

- 2.1. This sub grant Agreement becomes effective on the date of signing and shall apply to commitments made by the Sub-grantee in furtherance of program objectives through December 31, 2026.
- 2.2. All expenditures made with funds provided under this Sub-grant shall be for allowable program expenditures incurred during the period of this sub-grant.

### **3. ORIGINATING SOURCE OF FUNDING**

- 3.1. The originating source of the grant funds is LeadingAge Minnesota.
- 3.2. The originating grant period between the Connected Communities project and Leading Age Minnesota is from November 1, 2024, to May 28, 2027.

### **4. AMOUNT OF SUB-GRANT AND PAYMENT**

- 4.1. CC will pay Sub-grantee a total of \$25,240 for the successful completion of services provided under this Sub-grant.
- 4.2. It is anticipated that the amount obligated will be sufficient to cover project activities through the completion date. CC shall not be liable for reimbursing the Sub-grantee for any costs in

excess of the amount obligated or in excess of what is specifically and explicitly agreed to in this Sub-grant agreement.

4.3. Payment will be made to Sub-grantee according to the following schedule:

<b>Timeframe</b>	<b>Amount Disbursed</b>
Upon signing of agreement	\$13,970
Following 75% expenditure of initial disbursement	Remaining of subgrant

4.4. CC reserves the right to withhold cash payment for any of the following:

- Sub-grantee failure to make satisfactory progress towards the goals and objectives set forth in the purpose of this sub-grant.
- Sub-grantee default of or otherwise inability to adhere to the conditions or provisions of this agreement.
- Sub-grantee inability to submit reliable and/or timely reports or other deliverables as described in this agreement.

4.5. CC reserves the right to withhold 10% of the Sub-grant amount from final payment until after all required final project reports are received and accepted by CC.

4.6. All payments to Sub-grantee will be made by check to City of Willmar.

## **5. VENUE**

5.1. Programmatic activities under this agreement will be conducted in Kandiyohi County, Minnesota.

5.2. The CC office located at 901 Willmar Ave., SE, Willmar, will have administrative and programmatic oversight over the implementation of and compliance with the terms of this agreement.

## **6. COST SHARE REQUIREMENTS**

No cost share is required for the agreement.

## **7. SUB-GRANT MODIFICATIONS**

The following modifications require written approval from CC:

- To change the scope of the project objectives and/or activities.
- To change the location.
- To change the required funding amounts necessary to fulfill the stated project objectives.
- To change or temporarily replace key project staff.
- To reallocate between budget lines items an amount greater than 10 percent of the total Sub-grant award.
- To add a line item to the budget.
- To Sub-grant or contract any portion of this award to a third party.
- To change the effective period of the agreement.
- To hire a consultant not included in the budget.

## **8. REPORTING**

Financial Reporting

- 8.1. Sub-grantee shall maintain adequate records that clearly support the charges and expenditures incurred under this project. If requested by CC, Sub-grantee may be required to send the supporting documentation to support claims made on the Financial Report. CC may, at its discretion, request modification of any invoice or report when unallowable expenditures are incurred or charged to the Sub-grant, amend the schedule for reporting requirements, and/or require additional supporting documentation from the Sub-grantee as necessary.
- 8.2. Sub-grantee shall prepare financial reports on a bi-monthly basis (every two months) throughout the project period, with the first report due after two months of signing the sub-grant agreement.
- 8.3. Financial reports shall include at a minimum the following information:
  - Expense detail for period.
  - An accounting of year-to-date expenses, indicating cumulative *actuals versus budget*.
  - Grant balance remaining as of reporting period.
  - Any Cost Share progress report for period.
  - Supporting documentation, upon request.

#### Programmatic Reporting

- 8.4. Sub-grantee shall prepare written programmatic reports on a bi-monthly basis (every two months) throughout the project period, with the first report due after two months of signing the sub-grant agreement.
- 8.5. Programmatic reports should include the following information:
  - Major activities, program highlights, and accomplishments during this period.
  - Challenges faced and issues encountered, including any deviations or departures from the original project plan.
  - Corrective action planned to resolve implementation problems and the effect of these problems on the remaining schedule for achieving the project goals.
  - Significant findings and events.
  - Planned activities for the following quarter.
  - Administrative and logistical changes or constraints.
- 8.6. A final programmatic report under this Sub-grant must be provided to CC no later than one month after the sub-grant end date.
- 8.7. All required reports should be submitted to the CC Project Director, or his designee, according to the timetables indicated in this Agreement.

### **9. SUB-AWARDS**

No funds or other support provided hereunder to Sub-grantee may be subsequently passed on to any other entity in the form of a Sub-grant or contract without prior written approval from CC.

### **10. DOMICILE**

CC provides the following addresses as the *primary point of contact* in respect to any notice which may arise out of or in connection with this Sub-grant:

Name and Title:	John Shumlansky, Connected Communities Project Manager
Organization:	Bethesda
Street Name and Number:	901 Willmar Ave., SE
City, State and Zip:	Willmar, MN 56201
Telephone Number:	320-403-5641
Email Address:	<a href="mailto:John.shumlansky@bethesdaliving.org">John.shumlansky@bethesdaliving.org</a>

The **Sub-grantee** provides the following as the *primary point of contact* in respect to any notice that may arise out of or in connection with this Sub-grant:

Name and Title:	Britta Diem, Community Center Manager
Organization:	Willmar Community Center (City of Willmar)
Street Name and Number:	624 US-71 BUS
City, State and Zip:	Willmar, MN 56201
Telephone Number:	320-262-5288
Email Address	<a href="mailto:bdiem@willmarmn.gov">bdiem@willmarmn.gov</a>

**11. REPRESENTATIONS AND WARRANTIES**

11.1. Nothing herein shall be construed or implied to mean the establishment or existence of a partnership or joint venture between the parties, nor shall any party herein be construed to be employees, agents, or principals of the other party.

11.2. By signing this Agreement, all parties certify that the terms of conditions defined in this Agreement are accepted; that the Grantee and the Sub-Grantee are proper business entities permitted to do business; and that the individuals signing are competent parties authorized to enter into this Agreement on behalf of their respective agencies.

**12. SAFEGUARDING OF VULNERABLE ADULTS AND CHILDREN**

12.1. The subgrantee must immediately report to CC any credible allegations involving abuse or exploitation that relate to the project or staff funded by CC, and allegations that are not directly related to the project or staff funded by CC, but could be reasonably expected to impact the relationship between the subgrantee and CC or the reputation of the subgrantee or CC.

**Acknowledged and Accepted:**

By: \_\_\_\_\_  
 Leslie Valiant  
 City Administrator

By: \_\_\_\_\_  
 John Shumlansky, Project Manager  
 Connected Communities Project

Date: \_\_\_\_\_

Date: \_\_\_\_\_

Attachment: Detailed Budget

**Detailed Budget**

<b>Description</b>	<b>Rate</b>	<b>Freq.</b>	<b>Per</b>	<b>Total</b>
<b>National Senior Citizen Day - Elvis Band</b>	<b>\$ 600</b>	<b>1</b>	<b>Day</b>	<b>\$ 600</b>
<b>Bus Trips</b>				
Bus Rental	\$ 1,300	5	Trips	\$ 6,500
Jason Show staff	\$ 30	11	hrs	\$ 330
Twins Game Staff	\$ 30	10	hrs	\$ 300
State Fair Staff	\$ 30	12	hrs	\$ 360
State Fair Staff	\$ 30	12	hrs	\$ 360
Vikings Game Staff	\$ 30	10	hrs	\$ 300
<b>TOTAL</b>				<b>\$ 8,150</b>
<b>Senior Lunch Tours</b>	<b>\$ 1,000</b>	<b>5</b>	<b>buses</b>	<b>\$ 5,000</b>
Alexandria Trip Staff	\$ 30	5	hour	\$ 150
Joseph Trip Staff	\$ 30	6	hour	\$ 180
Glenwood Trip Staff	\$ 30	6	hour	\$ 180
Glenwood Trip Staff	\$ 30	6	hour	\$ 180
Waite Park Trip Staff	\$ 30	6	hour	\$ 180
Paynesville Trip Staff	\$ 30	4	hour	\$ 120
Hutchinson Trip Staff	\$ 30	5	hour	\$ 150
<b>TOTAL</b>				<b>\$ 6,140</b>
Newsletter Distribution	\$ 200	12	Newsletters	\$ 2,400
Shipping to WCT Warehouse	\$ 50	12	Mailings	\$ 600
<b>TOTAL</b>				<b>\$ 3,000</b>
<b>Community Coffee Speakers</b>				
Weather Meteorologists	\$ 750	1	session	\$ 750
Motivational Speaker	\$ 500	1	session	\$ 500
Book Author	\$ 500	1	session	\$ 500
Other	\$ 200	1	session	\$ 200
<b>TOTAL</b>				<b>\$ 1,950</b>
<b>Veterans Coffee - coffee and rolls</b>	<b>\$ 50</b>	<b>20</b>	<b>months</b>	<b>\$ 1,000</b>
<b>SwingStreet Big Band</b>	<b>\$ 2,600</b>	<b>1</b>	<b>session</b>	<b>\$ 2,600</b>
Swing Street Event Staff	\$ 30	5	hours	\$ 150
Swing Street Event Staff	\$ 30	5	hours	\$ 150
Swing Street Event Staff	\$ 30	5	hours	\$ 150
Swing Street Event Staff	\$ 30	5	hours	\$ 150
<b>TOTAL</b>				<b>\$ 3,200</b>
<b>Summer Leagues for Seniors - staff costs</b>	<b>\$ 200</b>	<b>6</b>	<b>months</b>	<b>\$ 1,200</b>
<b>TOTAL</b>				<b>\$ 25,240</b>



**City Council Action Request**

<b>Council Meeting Date:</b>	April 6, 2026	<b>Agenda Item Number:</b>	5.J.
<b>Agenda Section:</b>	Consent Items	<b>Originating Department:</b>	City Clerk
<b>Resolution:</b>	No	<b>Prepared By:</b>	Deborah Stulen, Administrative Assistant
<b>Ordinance:</b>	No	<b>Presented By:</b>	Vernae Larsen, City Clerk
<b>Item:</b>	Willmar Community Theatre Lawful Gambling Application		

**RECOMMENDED ACTION:**

Approve Willmar Community Theatre Lawful Gambling Application

**OVERVIEW:**

**BUDGETARY/FISCAL ISSUES:**

**ALTERNATIVES TO CONSIDER:**

**ATTACHMENTS:**

1. Willmar Community Theatre Lawful Gambling Application

LG220 Application for Exempt Permit

An exempt permit may be issued to a nonprofit organization that:
• conducts lawful gambling on five or fewer days, and
• awards less than \$50,000 in prizes during a calendar year.
If total raffle prize value for the calendar year will be \$1,500 or less, contact the Licensing Specialist assigned to your county by calling 651-539-1900.

Application Fee (non-refundable)

Applications are processed in the order received. If the application is postmarked or received 30 days or more before the event, the application fee is \$100; otherwise the fee is \$150.

Due to the high volume of exempt applications, payment of additional fees prior to 30 days before your event will not expedite service, nor are telephone requests for expedited service accepted.

ORGANIZATION INFORMATION

Organization Name: Willmar Community theatre DBA The Barn Theatre
Previous Gambling Permit Number: X-92274-18-007
Minnesota Tax ID Number, if any: 9694468
Federal Employer ID Number (FEIN), if any: 41-1357711
Mailing Address: P.O. Box 342
City: Willmar State: MN Zip: 56201 County: Kandiyohi
Name of Chief Executive Officer (CEO): Robbert A. Stone
CEO Daytime Phone: 3202359500 CEO Email: business@thebarntheatre.com
Email permit to (if other than the CEO):

NONPROFIT STATUS

Type of Nonprofit Organization (check one):
[ ] Fraternal [ ] Religious [ ] Veterans [x] Other Nonprofit Organization

Attach a copy of one of the following showing proof of nonprofit status:

(DO NOT attach a sales tax exempt status or federal employer ID number, as they are not proof of nonprofit status.)
[ ] A current calendar year Certificate of Good Standing
[ ] IRS income tax exemption (501(c)) letter in your organization's name
[ ] IRS - Affiliate of national, statewide, or international parent nonprofit organization (charter)

GAMBLING PREMISES INFORMATION

Name of premises where the gambling event will be conducted: Willmar Community theatre DBA The Barn Theatre
Physical Address (do not use P.O. box): 321 4th St SW
Check one:
[x] City: Willmar Zip: 56201 County: Kandiyohi
[ ] Township: Zip: County:
Date(s) of activity (for raffles, indicate the date of the drawing):
Check each type of gambling activity that your organization will conduct:
[ ] Bingo [ ] Paddlewheels [ ] Pull-Tabs [ ] Tipboards [x] Raffle

Gambling equipment for bingo paper, bingo boards, raffle boards, paddlewheels, pull-tabs, and tipboards must be obtained from a distributor licensed by the Minnesota Gambling Control Board. EXCEPTION: Bingo hard cards and bingo ball selection devices may be borrowed from another organization authorized to conduct bingo. To find a licensed distributor, go to www.mn.gov/gcb and click on Distributors under the List of Licensees tab, or call 651-539-1900.





**City Council Action Request**

<b>Council Meeting Date:</b>	April 6, 2026	<b>Agenda Item Number:</b>	5.K.
<b>Agenda Section:</b>	Consent Items	<b>Originating Department:</b>	City Clerk
<b>Resolution:</b>	No	<b>Prepared By:</b>	Deborah Stulen, Administrative Assistant
<b>Ordinance:</b>	No	<b>Presented By:</b>	Vernae Larsen, City Clerk
<b>Item:</b>	Willmar Firefighters Association Lawful Gambling Application		

**RECOMMENDED ACTION:**

Approve Willmar Firefighter Association Lawful Gambling Application

**OVERVIEW:**

**BUDGETARY/FISCAL ISSUES:**

**ALTERNATIVES TO CONSIDER:**

**ATTACHMENTS:**

1. Willmar Firefighter Association Lawful Gambling Application

LG220 Application for Exempt Permit

An exempt permit may be issued to a nonprofit organization that:
• conducts lawful gambling on five or fewer days, and
• awards less than \$50,000 in prizes during a calendar year.
If total raffle prize value for the calendar year will be \$1,500 or less, contact the Licensing Specialist assigned to your county by calling 651-539-1900.

Application Fee (non-refundable)

Applications are processed in the order received. If the application is postmarked or received 30 days or more before the event, the application fee is \$100; otherwise the fee is \$150.

Due to the high volume of exempt applications, payment of additional fees prior to 30 days before your event will not expedite service, nor are telephone requests for expedited service accepted.

ORGANIZATION INFORMATION

Organization Name: Willmar Firefighters Association
Previous Gambling Permit Number: X-92418-25-010
Minnesota Tax ID Number, if any:
Federal Employer ID Number (FEIN), if any: 20-0428826
Mailing Address: 515 2nd St SW
City: Willmar State: MN Zip: 56201 County: Kandiyohi
Name of Chief Executive Officer (CEO): Chad Robertson
CEO Daytime Phone: 320-444-4071 CEO Email: crobertson@willmarmn.gov
Email permit to (if other than the CEO): fhanson@willmarmn.gov

NONPROFIT STATUS

Type of Nonprofit Organization (check one):
[ ] Fraternal [ ] Religious [ ] Veterans [x] Other Nonprofit Organization

Attach a copy of one of the following showing proof of nonprofit status:

(DO NOT attach a sales tax exempt status or federal employer ID number, as they are not proof of nonprofit status.)

[ ] A current calendar year Certificate of Good Standing
Don't have a copy? Obtain this certificate from:
MN Secretary of State, Business Services Division
60 Empire Drive, Suite 100
St. Paul, MN 55103
Secretary of State website, phone numbers:
www.sos.state.mn.us
651-296-2803, or toll free 1-877-551-6767
[x] IRS income tax exemption (501(c)) letter in your organization's name
Don't have a copy? To obtain a copy of your federal income tax exempt letter, have an organization officer contact the IRS toll free at 1-877-829-5500.
[ ] IRS - Affiliate of national, statewide, or international parent nonprofit organization (charter)
If your organization falls under a parent organization, attach copies of both of the following:
1. IRS letter showing your parent organization is a nonprofit 501(c) organization with a group ruling; and
2. the charter or letter from your parent organization recognizing your organization as a subordinate.

GAMBLING PREMISES INFORMATION

Name of premises where the gambling event will be conducted (for raffles, list the site where the drawing will take place): Willmar Fire Station
Physical Address (do not use P.O. box): 515 2nd St SW
Check one:
[x] City: Willmar Zip: 56201 County: Kandiyohi
[ ] Township: Zip: County:
Date(s) of activity (for raffles, indicate the date of the drawing): 10-06-2026

Check each type of gambling activity that your organization will conduct:
[ ] Bingo [ ] Paddlewheels [ ] Pull-Tabs [ ] Tipboards [x] Raffle
Gambling equipment for bingo paper, bingo boards, raffle boards, paddlewheels, pull-tabs, and tipboards must be obtained from a distributor licensed by the Minnesota Gambling Control Board. EXCEPTION: Bingo hard cards and bingo ball selection devices may be borrowed from another organization authorized to conduct bingo. To find a licensed distributor, go to www.mn.gov/gcb and click on Distributors under the List of Licensees tab, or call 651-539-1900.

**LG220 Application for Exempt Permit**

**LOCAL UNIT OF GOVERNMENT ACKNOWLEDGMENT (required before submitting application to the Minnesota Gambling Control Board)**

**CITY APPROVAL  
for a gambling premises  
located within city limits**

The application is acknowledged with no waiting period.

The application is acknowledged with a 30-day waiting period, and allows the Board to issue a permit after 30 days (60 days for a 1st class city).

The application is denied.

Print City Name: City of Willmar

Signature of City Personnel: 

Title: City Clerk Date: 3/27/26

**The city or county must sign before submitting application to the Gambling Control Board.**

**COUNTY APPROVAL  
for a gambling premises  
located in a township**

The application is acknowledged with no waiting period.

The application is acknowledged with a 30-day waiting period, and allows the Board to issue a permit after 30 days.

The application is denied.

Print County Name: \_\_\_\_\_

Signature of County Personnel: \_\_\_\_\_

Title: \_\_\_\_\_ Date: \_\_\_\_\_

**TOWNSHIP (if required by the county)**  
On behalf of the township, I acknowledge that the organization is applying for exempted gambling activity within the township limits. (A township has no statutory authority to approve or deny an application, per Minn. Statutes, section 349.213.)

Print Township Name: \_\_\_\_\_

Signature of Township Officer: \_\_\_\_\_

Title: \_\_\_\_\_ Date: \_\_\_\_\_

**CHIEF EXECUTIVE OFFICER'S SIGNATURE (required)**

The information provided in this application is complete and accurate to the best of my knowledge. I acknowledge that the financial report will be completed and returned to the Board within 30 days of the event date.

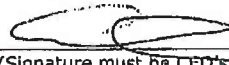
Chief Executive Officer's Signature:  Date: 03-25-2026

(Signature must be CEO's signature; designee may not sign)

Print Name: Chad Robertson

**REQUIREMENTS**

**Complete a separate application for:**

- all gambling conducted on two or more consecutive days; or
- all gambling conducted on one day.

Only one application is required if one or more raffle drawings are conducted on the same day.

**Financial report to be completed within 30 days after the gambling activity is done:**  
A financial report form will be mailed with your permit. Complete and return the financial report form to the Gambling Control Board.

Your organization must keep all exempt records and reports for 3-1/2 years (Minn. Statutes, section 349.166, subd. 2(f)).

**MAIL APPLICATION AND ATTACHMENTS**

**Mail application with:**

- \_\_\_\_\_ a copy of your proof of nonprofit status; and
- \_\_\_\_\_ application fee (non-refundable). If the application is postmarked or received 30 days or more before the event, the application fee is **\$100**; otherwise the fee is **\$150**. Make check payable to **State of Minnesota**.

**To:** Minnesota Gambling Control Board  
1711 West County Road B, Suite 300 South  
Roseville, MN 55113

**Questions?**  
Call the Licensing Section of the Gambling Control Board at 651-539-1900.

**Data privacy notice:** The information requested on this form (and any attachments) will be used by the Gambling Control Board (Board) to determine your organization's qualifications to be involved in lawful gambling activities in Minnesota. Your organization has the right to refuse to supply the information; however, if your organization refuses to supply this information, the Board may not be able to determine your organization's qualifications and, as a consequence, may refuse to issue a permit. If your organization supplies the information requested, the Board will be able to process the application. Your organization's name and address will be public information when received by the Board. All other information provided will be private data about your organization until the Board issues the permit. When the Board issues the permit, all information provided will become public. If the Board does not issue a permit, all information provided remains private, with the exception of your organization's name and address which will remain public. Private data about your organization are available to Board members, Board staff whose work requires access to the information; Minnesota's Department of Public Safety; Attorney General; Commissioners of Administration, Minnesota Management & Budget, and Revenue; Legislative Auditor, national, and international gambling regulatory agencies; anyone pursuant to court order; other individuals and agencies specifically authorized by state or federal law to have access to the information; individuals and agencies for which law or legal order authorizes a new use or sharing of information after this notice was given; and anyone with your written consent.

This form will be made available in alternative format (i.e. large print, braille) upon request.

*An equal opportunity employer*



### City Council Action Request

<b>Council Meeting Date:</b>	April 6, 2026	<b>Agenda Item Number:</b>	5.L.
<b>Agenda Section:</b>	Consent Items	<b>Originating Department:</b>	Finance
<b>Resolution:</b>	No	<b>Prepared By:</b>	Tom Odens, Finance Director
<b>Ordinance:</b>	No	<b>Presented By:</b>	Vernae Larsen, City Clerk
<b>Item:</b>	Accounts Payable Report, 3/12/2026 - 4/2/2026		

**RECOMMENDED ACTION:**

Review and Approve Accounts Payable Listing

**OVERVIEW:**

**BUDGETARY/FISCAL ISSUES:**

Reduction of Departmental Budgets by amounts approved.

**ALTERNATIVES TO CONSIDER:**

**ATTACHMENTS:**

1. 03.12.26 thru 04.02.26
2. EFT CK 646-649

# Vendor Payment Listing

March 12, 2026 Through April 2, 2026



VENDOR	VENDOR NAME	ACCOUNT	AMOUNT	CHECK NO	INVOICE	INVOICE DESCRIPTION
103800	AFLAC	101801 5075	\$ 319.76	76987	418029	Premiums withheld from employees 3/20
102336	CANON FINANCIAL SERV	101809 5420	\$ 140.23	76988	42824485	291358-1
102336	CANON FINANCIAL SERV	101809 5420	\$ 127.77	76988	42824486	291358-2
102336	CANON FINANCIAL SERV	101809 5420	\$ 134.15	76988	42824487	291358-3
102336	CANON FINANCIAL SERV	101809 5420	\$ 72.11	76988	42824488	291358-4
102336	CANON FINANCIAL SERV	651890 5420	\$ 74.96	76988	42824489	291358-5
100222	DUIININCK INC	425830 5320	\$ 447,533.59	76989	Appl #4 2503-C	Project No. 2503-C Final Pay Application
103410	HMD PHOTOGRAPHY LLC	101809 5460	\$ 225.75	76990	5823	S. Stefanick candid
100375	KANDIYOHI CO-OP ELEC	101830 5350	\$ 390.69	76991	STMT/03-26	Kandi Co-Op Electric
100375	KANDIYOHI CO-OP ELEC	651892 5350	\$ 39.00	76991	STMT/03-26	Kandi Co-Op Electric
100375	KANDIYOHI CO-OP ELEC	651893 5350	\$ 1,541.00	76991	STMT/03-26	Kandi Co-Op Electric
103143	US BANK EQUIPMENT FI	101809 5420	\$ 751.80	76992	578187767	500-0664928-000/001
102915	VERIZON WIRELESS	101809 5290	\$ 2,135.45	76993	6138084871	Verizon Mar/Apr
102915	VERIZON WIRELESS	101841 5290	\$ 38.41	76993	6138084871	Verizon Mar/Apr
102915	VERIZON WIRELESS	651893 5290	\$ 80.08	76993	6138084871	Verizon Mar/Apr
103111	ACCESS LIFTS	101845 5450	\$ 1,003.00		M4103SA-14	Contract Renewal
104324	Adrianna Rodriguez	208850 5370	\$ 2.90		03112026	CVB-Mileage Reimb and parking
104324	Adrianna Rodriguez	208851 5472	\$ 153.40		03112026	CVB-Mileage Reimb and parking
102061	ALEX AIR APPARATUS 2	424821 5220	\$ 3,061.00		INV-54066	Vent Fan for new truck
103557	AMAZON CAPITAL SERVI	101803 5200	\$ 110.60		1RRL-Q944-73X1	Paper towels
103557	AMAZON CAPITAL SERVI	101803 5210	\$ 227.11		1XMW-KWRH-M44P	Binders and Tabs
103557	AMAZON CAPITAL SERVI	101809 5220	\$ 139.90		1F63-9NYL-GWXP	Additional access point for CvC Cardinal Arena
103557	AMAZON CAPITAL SERVI	101809 5220	\$ 79.90		1PQT-139R-7Q7K	(10) Speck iPhone 16 case
103557	AMAZON CAPITAL SERVI	101809 5300	\$ 349.00		1HXN-6HYG-FJY1	Replacement battery for P.D. UPS
103557	AMAZON CAPITAL SERVI	101809 5490	\$ 51.41		14QW-JKRW-MXPC	WLLMR CNNCT - Access Point for NOC
103557	AMAZON CAPITAL SERVI	101809 5490	\$ 69.29		1Y9L-NLMT-PQTL	WLLMR CNNCT - NOC temp. fiber connection gear
103557	AMAZON CAPITAL SERVI	101820 5220	\$ 9.99		143F-1PYP-796H	Two Point and Tradtl Rifle Sling
103557	AMAZON CAPITAL SERVI	101821 5220	\$ 339.90		16DF-3DHD-WT6N	Traffic control signs
103557	AMAZON CAPITAL SERVI	101830 5200	\$ 61.94		1C4H-KL9R-G6JN	Label maker refills, Basketball hoop nets
103557	AMAZON CAPITAL SERVI	101844 5200	\$ 129.97		1HNY-N3K6-W6RG	Battery for drone
103557	AMAZON CAPITAL SERVI	101844 5200	\$ 408.53		1JHD-C3XD-96L3	DOAC supplies, park and rec supplies, first aid
103557	AMAZON CAPITAL SERVI	101845 5220	\$ 533.00		16FR-7GND-C4YN	Small Tool- Blade, Brake and Plate
103557	AMAZON CAPITAL SERVI	101845 5220	\$ 13.30		1MJL-C3PR-FK4Y	Locks
103557	AMAZON CAPITAL SERVI	101845 5300	\$ 268.30		13XH-WCV4-G9JY	Urinal Parts and tubes
103557	AMAZON CAPITAL SERVI	101847 5200	\$ (9.99)		11V1-VWD1-RCH	puzzle return
103557	AMAZON CAPITAL SERVI	101847 5200	\$ 32.10		13DM-3C44-6Q9V	daddy daughter
103557	AMAZON CAPITAL SERVI	101847 5200	\$ 64.93		197X-WGQX-NDFR	Marbles
103557	AMAZON CAPITAL SERVI	101847 5200	\$ 40.98		1FRG-RL76-NLWM	Hair Clips-Marbles-Daddy Daughter
103557	AMAZON CAPITAL SERVI	101847 5200	\$ (19.98)		1HNY-N3K6-N9GM	puzzle return
103557	AMAZON CAPITAL SERVI	101847 5200	\$ 31.98		1J9Q-7HVV-Y7MR	Daddy Daughter and Egg hunt items
103557	AMAZON CAPITAL SERVI	101847 5200	\$ 48.42		1MFF-97DD-7HK7	Candy for daddy daughter
103557	AMAZON CAPITAL SERVI	101847 5200	\$ (35.91)		1MND-Y6HQ-336V	return of puzzles
103557	AMAZON CAPITAL SERVI	101847 5200	\$ 28.48		1NNX-YLMA-LJXX	Daddy Daughter
103557	AMAZON CAPITAL SERVI	101847 5200	\$ 111.01		1TVJ-XCWL-4TGW	Daddy Daughter Formal
103557	AMAZON CAPITAL SERVI	101848 5200	\$ 202.09		1JHD-C3XD-96L3	DOAC supplies, park and rec supplies, first aid
103557	AMAZON CAPITAL SERVI	651890 5200	\$ 64.74		1NNX-YLMA-J97X	General supplies
100057	AMERICAN WELDING & G	101845 5460	\$ 630.19		0011538274	Fire Extinguishers Check
100057	AMERICAN WELDING & G	651890 5300	\$ 42.80		0011538966	Welder tip
100057	AMERICAN WELDING & G	651890 5420	\$ 38.68		0011503859	Cylinder rent
102954	ANDERSON LAW OFFICES	101807 5275	\$ 112.50		2882	City Legal Services March 2026
102954	ANDERSON LAW OFFICES	101820 5275	\$ 26,588.03		2882	City Legal Services March 2026
103008	ASPEN MILLS	101820 5080	\$ 199.95		373182	Boots for Officer Maschino
100075	AT&T MOBILITY	101809 5290	\$ 2,139.39		87296610156X04032026	FirstNet Feb/Mar
103843	ATWATER FESTIVAL COM	208851 5474	\$ 500.00		031726	CVB - Atwater Festival Days Sponsorship
103610	AUSTIN INCORPORATED	230838 5360	\$ 120.00		51972	Septic Pumping
103610	AUSTIN INCORPORATED	230838 5360	\$ 120.00		52058	Septic Pumping
103610	AUSTIN INCORPORATED	230838 5360	\$ 120.00		52132	Septic Pumping
103838	BAKER/DEREK	651890 5080	\$ 159.99		020426	Safety boot reimbursement Baker
102860	BATTERY WHOLESale IN	651891 5300	\$ 42.18		285103WIL	Radio LS UPS
100096	BEACON ATHLETICS LLC	455845 5600	\$ 5,157.00		0629759-IN	Batting Cage Nets
100097	BECKER ARENA PRODUCT	101845 5320	\$ 1,979.04		618840	Seamless Glass
103377	BENSON LAUNDRY	101845 5460	\$ 94.61		437859	Towel Service
103377	BENSON LAUNDRY	101845 5460	\$ 94.61		438649	Towel Service

# Vendor Payment Listing

March 12, 2026 Through April 2, 2026



VENDOR	VENDOR NAME	ACCOUNT	AMOUNT	CHECK NO	INVOICE	INVOICE DESCRIPTION
104299	BFirst Industrial	101830 5220	\$ 107.82		80032714-00	M12 Batteries
104299	BFirst Industrial	651890 5300	\$ 77.62		80032356-00	Plant exhaust fan repair
104458	Blake Giles	101821 5370	\$ 75.00		031526	Reimbursement for overnight training expenses
101010	BOLTON & MENK INC	101831 5460	\$ 18,731.00		0390260	2026 Prof. Services 1-31 thru 2-27-26
101010	BOLTON & MENK INC	101831 5460	\$ 4,085.00		0390266	City Engineer 1-31 thru 2-27-26
101010	BOLTON & MENK INC	205807 5460	\$ 6,618.00		0390268	Fiber Network
101010	BOLTON & MENK INC	205830 5460	\$ 592.00		0390272	TH 40 Turn Lanes Prof. Svcs
101010	BOLTON & MENK INC	420833 5460	\$ 5,693.00		0390265	Project No. 2605-B Prof Svcs
101010	BOLTON & MENK INC	420845 5460	\$ 1,410.00		0390269	Outdoor Covered Rink
101010	BOLTON & MENK INC	425830 5460	\$ 0.50		0379819-2	2503-E 2025 County Improvements
101010	BOLTON & MENK INC	425830 5460	\$ 1,181.00		0390259	Project No. 2503-D Prof. Services
101010	BOLTON & MENK INC	425830 5460	\$ 6,946.00		0390262	Project No. 2504-B Prof Svcs
101010	BOLTON & MENK INC	425830 5460	\$ 8,962.99		0390271	Project No. 2503-C Prof Svcs
101010	BOLTON & MENK INC	426830 5460	\$ 92,572.00		0390261	Project No. 2501-B Prof. Services
101010	BOLTON & MENK INC	426830 5460	\$ 854.50		0390264	Project No. 2605-A Prof Services
101010	BOLTON & MENK INC	427830 5460	\$ 1,278.50		0390263	Project No. 2604-B Prof Svcs
101010	BOLTON & MENK INC	430838 5460	\$ 5,000.00		0391287	Acquisition of SRE for Airport
101010	BOLTON & MENK INC	430838 5460	\$ 5,000.00		0391289	AIG Funded Runway 13/31 NAVAIDS, Beacon
101010	BOLTON & MENK INC	432891 5460	\$ 18,570.99		0390274	Iverson Park LS Prof. Services
101010	BOLTON & MENK INC	432893 5460	\$ 1,368.00		0390267	ELLS 7, 8 & 9 Prof. Svcs
101010	BOLTON & MENK INC	454844 5460	\$ 4,911.00		0390270	Robbins Island Amphitheater
103733	BOX/KYLE	101801 5380	\$ 202.09		03122026	LMC Day on the Hill Reimbursements
103733	BOX/KYLE	101801 5380	\$ 207.73		033126	Reimbursement for CGMC Legislative Action Day
103820	BRECZINSKI/BRENT	101821 5370	\$ 75.00		031426	Reimbursement for overnight training expenses
101980	BSE	101830 5310	\$ 341.40		932150270	T8 Lamps
101980	BSE	101830 5310	\$ 68.67		932190145	Outlet
101980	BSE	101844 5220	\$ 47.55		932159526	Zip Ties for Soccer Nets
104250	Carlson & Stewart	101845 5300	\$ 8,052.93		76117	Compressor Maintenance
102542	CARRANZA/NORMA I	101820 5460	\$ 150.00		303	Interpreting Services for Officer
102542	CARRANZA/NORMA I	101820 5460	\$ 150.00		304	Interpreting services for Officer
103390	CENTRACARE	101820 5460	\$ 65.00		RMH811	Blood Draws
104030	Chad Campbell	101844 5460	\$ 1,925.00		040126	Rec Basketball Official( 35 Games)
104444	Chad Robertson	101821 5260	\$ 20.00		031426	Reimbursements for overnight training expenses
104444	Chad Robertson	101821 5370	\$ 75.00		031426	Reimbursements for overnight training expenses
100156	CHAPPELL CENTRAL INC	101821 5460	\$ 257.84		SVC-129531	Time delay relay, service work
100156	CHAPPELL CENTRAL INC	101847 5300	\$ 3,857.92		SVC-129598	Replaced heat exchanger and parts
100156	CHAPPELL CENTRAL INC	651890 5300	\$ 725.60		SVC-129557	HVAC repair
100156	CHAPPELL CENTRAL INC	651890 5490	\$ 1,565.66		SVC-129626	Plant boiler repair
100156	CHAPPELL CENTRAL INC	651891 5300	\$ 1,191.02		SVC-129563	JOTS 1 HVAC repair
100736	CHARTER COMMUNICATIO	101841 5290	\$ 94.64		175505001032126	Mar/Apr TV
101708	CINTAS CORPORATION	101845 5460	\$ 228.73		5323793418	First Aid Kits
102157	CLARKE MOSQUITO CONT	101830 5200	\$ 12,958.00		005115418	Mosquito larva tablets
104070	Column Software PBC	101807 5330	\$ 70.36		B15E1683-0137	Vaxxinoa Annexation Public Notice
103677	COORDINATED BUSINESS	208850 5460	\$ 351.40		TNA126663	CVB- Managed IT
104205	Courtland Waste	432892 5620	\$ 225,235.75		01-45187	Biosolids Trailer
103979	DONAHOE/THOMAS	101844 5460	\$ 90.00		040126	Adult Volleyball Official (3 Gams)
102293	DONOHUE & ASSOCIATES	651890 5460	\$ 1,348.50		14714-05	JOT's BNR phase 1 completion
100212	DOOLEY'S PETROLEUM I	101 1350	\$ 26,019.96		848832	Unleaded and diesel fuel
100212	DOOLEY'S PETROLEUM I	101844 5350	\$ 521.74		410999	Propane for 4-Seasons
100212	DOOLEY'S PETROLEUM I	101844 5350	\$ 260.16		481917	Propane
100212	DOOLEY'S PETROLEUM I	101844 5350	\$ 260.36		481962	Propane
100222	DUININCK INC	101830 5320	\$ 2,617.90		568992	Cold Mix
100810	FERGUSON ENTERPRISES	101845 5220	\$ 25.52		2504896	Plumbing supplies
900163	FIELDTURF INC.	455845 5600	\$ 6,852.94		000738280	Turf for batting cages
102973	FLEETPRIDE	101 1350	\$ 600.90		132971540	filters
102973	FLEETPRIDE	101 1350	\$ 20.16		132994481	Filter
102973	FLEETPRIDE	101 1350	\$ 8.33		132994482	Filter
102973	FLEETPRIDE	101 1350	\$ 31.35		133002042	Filters
102973	FLEETPRIDE	101 1350	\$ 83.92		133002913	Filter
102973	FLEETPRIDE	101 1350	\$ 26.33		133077039	Filters
101791	FP MAILING SOLUTIONS	101820 5270	\$ 188.16		RI107136508	Postal Machine 3mo Rent 03/03-06/02/26
100293	GENERAL MAILING SERV	101803 5270	\$ 34.72		76442	Postage 02/23-02/27/2026
100293	GENERAL MAILING SERV	101803 5270	\$ 113.60		76580	Postage 03/02-03/06/2026

# Vendor Payment Listing

March 12, 2026 Through April 2, 2026



VENDOR	VENDOR NAME	ACCOUNT	AMOUNT	CHECK NO	INVOICE	INVOICE DESCRIPTION
100293	GENERAL MAILING SERV	101803 5270	\$ 51.77		76624	Postage 03/09-03/13/2026
100293	GENERAL MAILING SERV	101820 5270	\$ 38.63		76571	Mailing Services
100293	GENERAL MAILING SERV	101821 5270	\$ 4.65		76442	Postage 02/23-02/27/2026
100293	GENERAL MAILING SERV	101821 5270	\$ 3.72		76580	Postage 03/02-03/06/2026
100293	GENERAL MAILING SERV	101821 5270	\$ 3.72		76624	Postage 03/09-03/13/2026
100293	GENERAL MAILING SERV	651890 5270	\$ 1.86		76624	Postage 03/09-03/13/2026
102835	GOODIN COMPANY	651890 5300	\$ 364.29		5537517-00	Town flush valve
100786	GRAINGER INC	101845 5300	\$ 110.80		9826303787	vacuum hose for shop vac
100786	GRAINGER INC	101845 5300	\$ 88.72		9836494634	wheel for cart
100786	GRAINGER INC	651890 5080	\$ 48.26		9837981191	Safety signs
100786	GRAINGER INC	651890 5080	\$ 78.25		9840317326	Safety signs
100786	GRAINGER INC	651890 5200	\$ 28.77		9818182108	General supplies
100786	GRAINGER INC	651890 5200	\$ 460.77		9843058596	RWW pump fuses
100786	GRAINGER INC	651890 5200	\$ 106.53		9851282526	Plant supplies
100786	GRAINGER INC	651890 5300	\$ 116.36		9845257592	Exhaust fan motor
101887	GRAND RENTAL STATION	101830 5200	\$ 15.00		1-589118	Propane
104457	Granite City Roofing	651890 5310	\$ 8,150.00		TM0404	Ind. selector roof repair
103466	GREAT PLACES MINNESO	208851 5472	\$ 500.00		15514	CVB-Advertising
100316	HACH COMPANY	651890 5300	\$ 251.05		14931067	Sensor cap
103184	HANSON *PETTY CASH/F	101821 5380	\$ 90.00		03172026	County Chiefs & Lake Region Mtgs.,
101486	HANSON/FRANK	101821 5200	\$ 132.86		032026	Coffee for the fire sation
102608	HARTLAND OFFICIALS A	101844 5460	\$ 740.00		022626	Adult Rec Official 27 nights
103980	HARTLEY/JOHN	101844 5460	\$ 1,410.00		040126	Rec Volleyball Official (47 Games)
100324	HAUG IMPLEMENT CO -	101830 5300	\$ 141.36		546736	Hyd. Filter
100324	HAUG IMPLEMENT CO -	101830 5300	\$ (84.66)		STMT/02-26	Credit on Account
100325	HAWKINS INC	651890 5200	\$ 155.30		7354924	Antifoam
100325	HAWKINS INC	651890 5200	\$ 10,965.00		7371275	Ind. ferric
102036	HEGLUND CATERING	101811 5470	\$ 350.59		17181	Latino Service Providers Network Meal
100330	HEIMAN FIRE EQUIPMEN	424821 5220	\$ 1,368.52		0953568-IN	Tool Brackets for new Truck
103650	HIGHLAND PRODUCTS GR	101844 5220	\$ 855.00		310045376	Park Benches
100333	HILLYARD\HUTCHINSON	101830 5360	\$ 2,419.30		90085501	Gloves, Kleenex, Glass Cleaner, Toilet Paper
100333	HILLYARD\HUTCHINSON	101830 5360	\$ 554.45		90088820	Foaming hand soap
100333	HILLYARD\HUTCHINSON	101830 5360	\$ (476.41)		90091981	Hand Soap return
100333	HILLYARD\HUTCHINSON	101845 5300	\$ 50.83		90080672	Access Door
100333	HILLYARD\HUTCHINSON	101845 5300	\$ 64.95		90080674	Brush Strip
104463	Holiday Inn Indianap	101821 5370	\$ 2,583.36		1001	FDIC Hotel
103760	HOMETOWN FIBER	205807 5460	\$ 19,615.00		5489	Willmar Connect Work - Feb 2026
102486	IN CONTROL INC	651890 5490	\$ 1,640.50		S-INV03507	Generator control board diagnostics
103023	INNOVATIVE OFFICE SO	101803 5210	\$ 34.13		INS073537	casters
103355	JOHANNECK WTR CONDIT	101803 5420	\$ 46.00		ER1801-3-099	Water cooler rental
103355	JOHANNECK WTR CONDIT	101830 5200	\$ 28.00		146741	Softener salt
103355	JOHANNECK WTR CONDIT	651890 5200	\$ 25.00		146678	Lab water
103355	JOHANNECK WTR CONDIT	651890 5200	\$ 25.00		146967	Lab water
103355	JOHANNECK WTR CONDIT	651890 5200	\$ 11.00		146968	Lab water
103355	JOHANNECK WTR CONDIT	651890 5200	\$ 25.00		147211	Lab water
103355	JOHANNECK WTR CONDIT	651890 5200	\$ 25.00		147475	Lab water
103355	JOHANNECK WTR CONDIT	651890 5200	\$ 11.00		147477	Lab water
103355	JOHANNECK WTR CONDIT	651890 5420	\$ 1.00		CR1711-3-212	Cooler rent
103355	JOHANNECK WTR CONDIT	651890 5420	\$ 2.00		CR1711-3-224	Cooler rent
104464	Jon Larson	101844 5310	\$ 1,880.00		040126	Fence Repair at Orange Field
100867	KANDI STEEL AND FAB	101830 5200	\$ 11.62		8104	Flat Aluminum for plaques on benches
101465	KANDIYOHI CO & CITY	101801 5370	\$ 70.00		03132026	Annual Governor's International Trade Awards
101465	KANDIYOHI CO & CITY	101802 5370	\$ 500.60		03132026	Annual Governor's International Trade Awards
101465	KANDIYOHI CO & CITY	101807 5370	\$ 70.00		03132026	Annual Governor's International Trade Awards
100376	KANDIYOHI CO AUDITOR	101803 5490	\$ 150.00		Assess #4393	Assess for Unpaid Invoices #4393
100376	KANDIYOHI CO AUDITOR	101821 5490	\$ 30.00		Assess #4393	Assess for Unpaid Invoices #4393
100376	KANDIYOHI CO AUDITOR	101830 5320	\$ 11,703.53		032326	Annual Drainage Assessments
100376	KANDIYOHI CO AUDITOR	101830 5490	\$ 20.00		Assess #4393	Assess for Unpaid Invoices #4393
100376	KANDIYOHI CO AUDITOR	101833 5320	\$ 3,502.29		032326	Annual Drainage Assessments
100376	KANDIYOHI CO AUDITOR	230838 5320	\$ 1,770.21		032326	Annual Drainage Assessments
100376	KANDIYOHI CO AUDITOR	425830 5490	\$ 13,070.00		Assess Cards 3.23.26	Special Assess Cards Roll #465 Project #2501
100376	KANDIYOHI CO AUDITOR	651890 5320	\$ 871.31		032326	Annual Drainage Assessments
100376	KANDIYOHI CO AUDITOR	651893 5490	\$ 696.00		ELLS Usage Fees	Eagle Lake Sewer Usage Fees

# Vendor Payment Listing

March 12, 2026 Through April 2, 2026



VENDOR	VENDOR NAME	ACCOUNT	AMOUNT	CHECK NO	INVOICE	INVOICE DESCRIPTION
102296	KANDIYOHI CO RECYCLI	101843 5360	\$ 16.00		1027	Light bulb disposal
102296	KANDIYOHI CO RECYCLI	101845 5360	\$ 162.00		1017	Light bulb disposal
103138	KING'S ELECTRIC LLC	101843 5310	\$ 1,088.60		3662	Replace & repair lights in Auditorium
103579	KLAVETTER/JORDAN	101807 5480	\$ 85.70		031926	Reimbursement for Flashlight used on inspections
103825	LAWTON/JAY	101844 5460	\$ 900.00		040126	Rec Volleyball Official ( 30 GAMES)
103129	LIEBL/JEFFREY	101820 5080	\$ 204.00		040126	Safety Boot Reimbursement
102380	LIVINGOOD/ROSS	101820 5380	\$ 359.08		031326	Meal & Gas Reimbursement while at Training
103376	LLOYD SECURITY INC	101830 5310	\$ 431.88		1000009374	Annual fire alarm charges
103226	LOCAL GOV'T INFORMAT	101809 5400	\$ 461.00		153677	LOGIS SIEM hosting
102593	LOFFLER COMPANIES	101809 5420	\$ 268.74		578491664	500-0757297-000
100427	MACQUEEN EQUIPMENT I	101830 5300	\$ 730.68		P70858	Corner Window
101121	MAGNUSON SHEET METAL	101821 5300	\$ 7,533.00		1031	Co-Ray-Vac burner assembly replacement
101121	MAGNUSON SHEET METAL	101821 5300	\$ 342.65		1032	Redo gas lines
100446	MCMMASTER-CARR SUPPLY	651890 5300	\$ 81.37		59382738	Boiler fitting's
100449	MENARDS	101803 5200	\$ 19.28		07832	Electric tape, Heat shrink terminal kit
100449	MENARDS	101821 5200	\$ 6.98		07392	door stop, kickdown, wiper blade, premix, brake cl
100449	MENARDS	101821 5210	\$ 78.96		07703	(12) bags of soft salt & (3) 4lb headblow hammers
100449	MENARDS	101821 5220	\$ 14.87		07392	door stop, kickdown, wiper blade, premix, brake cl
100449	MENARDS	101821 5220	\$ 38.97		07703	(12) bags of soft salt & (3) 4lb headblow hammers
100449	MENARDS	101821 5260	\$ 45.08		07392	door stop, kickdown, wiper blade, premix, brake cl
100449	MENARDS	101821 5300	\$ 13.98		07392	door stop, kickdown, wiper blade, premix, brake cl
100449	MENARDS	101830 5080	\$ 23.97		07878	Ladders, Safety Glasses
100449	MENARDS	101830 5200	\$ 31.98		07427	Ratchet Strap
100449	MENARDS	101830 5200	\$ 7.99		07444	Mounting Tape
100449	MENARDS	101830 5220	\$ 638.00		07878	Ladders, Safety Glasses
100449	MENARDS	101830 5300	\$ 21.91		07933	U-bolt, Nuts
100449	MENARDS	101843 5200	\$ 62.26		4825	Drill bit, tapcon, jigsaw blade
100449	MENARDS	101844 5210	\$ 70.30		07752	Office Supplies and Plumbing
100449	MENARDS	101844 5220	\$ 6.66		07441	Wall Divider
100449	MENARDS	101845 5220	\$ 31.74		06963	Small Tools
100449	MENARDS	101845 5220	\$ 115.11		07247	Ice Melt and Diamond cut wheel
100449	MENARDS	101845 5220	\$ 51.96		07346	Ice Melt
100449	MENARDS	101845 5220	\$ 110.02		07752	Office Supplies and Plumbing
100449	MENARDS	101847 5200	\$ 21.56		07983	DOWELS
100449	MENARDS	101847 5200	\$ 15.39		4879	PVC pipe
100449	MENARDS	101847 5300	\$ 5.98		07572	Caulk gun
100449	MENARDS	651890 5200	\$ 21.54		07655	General supplies
100449	MENARDS	651890 5200	\$ 99.98		08191	Extension cords
102699	MIKE'S SMALL ENGINE	101830 5080	\$ 149.99		36288	Chainsaw Chap
102699	MIKE'S SMALL ENGINE	101830 5220	\$ 549.99		36339	Backpack Blower
101805	MINI BIFF LLC	101844 5420	\$ 144.84		18863	Mini Biff Robbins Island
102565	MINNWEST TECHNOLOGY	208850 5420	\$ 469.33		3020460	CVB-Utilities 01/22-02/28/26
102565	MINNWEST TECHNOLOGY	208850 5420	\$ 800.00		3020511	CVB - April Rent
100499	MN ELEVATOR INC	101803 5310	\$ 204.52		1180408	Bi-monthly elevator service
101064	MN POLLUTION CONTROL	101830 5450	\$ 345.00		10000226014	Water Permit Annual Fees
102916	MN SECRETARY OF STAT	101820 5450	\$ 120.00		040126	Notary for Melissa Jambor
100424	M-R SIGN CO INC	101830 5320	\$ 506.36		230668	Traffic signal signs
103756	MR. CLEAN WILLMAR CL	101844 5460	\$ 693.00		STMT/01-26	Shelter Cleaning January 2026
100541	MUNICIPAL UTILITIES	101821 5350	\$ 739.97		STMT/02-2026	Municipal Utilities Feb 2026
100541	MUNICIPAL UTILITIES	101830 5350	\$ 1,444.52		STMT/02-2026	Municipal Utilities Feb 2026
100541	MUNICIPAL UTILITIES	230838 5350	\$ 2,519.03		STMT/02-2026	Municipal Utilities Feb 2026
100541	MUNICIPAL UTILITIES	651890 5350	\$ 47,808.83		STMT/02-2026	Municipal Utilities Feb 2026
100541	MUNICIPAL UTILITIES	651891 5350	\$ 286.13		STMT/02-2026	Municipal Utilities Feb 2026
100544	MVTL LABORATORIES IN	651890 5460	\$ 576.00		1348925	Lab test's
100544	MVTL LABORATORIES IN	651890 5460	\$ 87.25		1349598	Lab test's
100544	MVTL LABORATORIES IN	651890 5460	\$ 63.25		1350522	Lab test
103502	NELSON SANITATION &	651891 5490	\$ 10,155.04		INV/2026/2421	Downtown televising grant project
103502	NELSON SANITATION &	651891 5490	\$ 60,576.33		INV/2026/2422	Downtown televising grant project
103502	NELSON SANITATION &	651891 5490	\$ 1,800.00		INV/2026/2423	Becker Ave. televising
103502	NELSON SANITATION &	651891 5490	\$ 1,209.30		INV/2026/2424	Becker Ave. root removal
102547	Noe Carranza	101820 5460	\$ 150.00		306	Interpreting services for ICR 26002910
102547	Noe Carranza	101820 5460	\$ 225.00		307	Interpreting services for WPD
103605	NORTH CENTRAL INTERN	101821 5300	\$ 608.87		X201154397:01	Air dryer #5276/062633

# Vendor Payment Listing

March 12, 2026 Through April 2, 2026



VENDOR	VENDOR NAME	ACCOUNT	AMOUNT	CHECK NO	INVOICE	INVOICE DESCRIPTION
103605	NORTH CENTRAL INTERN	101821 5300	\$ (250.00)		X201154432:01	Air Dryer core return
103605	NORTH CENTRAL INTERN	101830 5300	\$ 87.40		X201154726:01	Quick Release Valve
103605	NORTH CENTRAL INTERN	101830 5300	\$ (45.05)		X201154727:01	exchange for the correct release valve
104456	North Star Training	101821 5370	\$ 895.00		622	Instructor 1 Certification
103945	ODENS/THOMAS	101806 5370	\$ 191.93		040126	Reimbursement for CGMC Legislative Action Day
102329	O'MALLEY & KRON LAND	101802 5460	\$ 400.00		14050	Certificate of Survey for Additional Property
900120	ON THE RUN PROMOTION	208851 5474	\$ 1,000.00		02172026	CVB - Sponsorship
103667	OVERHEAD HOIST & CRA	651890 5300	\$ 1,050.75		4311	Hoist repair
104404	Pam Bruining	101847 5200	\$ 59.00		033126	reissue check 76153 Mahjong Set
101968	PEST PRO II	101847 5360	\$ 41.50		26828	pest pros service Jan 2026
100614	PIONEERLAND LIBRARY	101842 5490	\$ 124,167.25		03132026	1st Qtr Request 2026
100620	PLUNKETT'S PEST CONT	101803 5310	\$ 450.93		10437231	Pest control
100342	POWER PLAN OIB	101830 5300	\$ 1,287.67		P0443311	Brake Pedal Assemblies.
100342	POWER PLAN OIB	101830 5300	\$ 510.39		P0461811	OHV filter housing
104252	PreCise MRM LLC	101830 5400	\$ 400.00		IN200-2012147	Precise location services
100374	PREMIUM WATERS INC	101821 5200	\$ 14.99		300705066	water
100374	PREMIUM WATERS INC	101821 5200	\$ 14.99		330702975	water
100374	PREMIUM WATERS INC	101821 5200	\$ 8.00		330706989	water
100374	PREMIUM WATERS INC	101847 5200	\$ 59.47		330709457	water
100374	PREMIUM WATERS INC	101847 5200	\$ 10.99		330712171	water
100624	PRINT MASTERS	101809 5490	\$ 147.00		94712	Business Cards - Johnson
103529	PRO WATER SOLUTIONS	101845 5300	\$ 661.50		16133	Solar Salt
104459	Quality Appliance	101821 5220	\$ 539.00		102031	Amana Dryer
100639	RAMBOW INC	101844 5200	\$ 98.00		670235	work polos
103870	RAMBOW/JON	101844 5460	\$ 1,925.00		040126	basketball official (35 games)
103867	RS AMERICAS INC	651891 5300	\$ 756.42		9021900131	24vdc power supply
102142	SCHUELER/ALLEN	651890 5370	\$ 1,039.97		030226	MRWA conference
100685	SERVICE CENTER/CITY	101807 5260	\$ 316.60		STMT/02-2026	UNLEADED AND DIESEL FUEL FEB 2026
100685	SERVICE CENTER/CITY	101820 5260	\$ 5,009.93		STMT/02-2026	UNLEADED AND DIESEL FUEL FEB 2026
100685	SERVICE CENTER/CITY	101820 5300	\$ 474.50		STMT/02-26	February 2026 Equipment Repair parts
100685	SERVICE CENTER/CITY	101821 5260	\$ 466.05		STMT/02-2026	UNLEADED AND DIESEL FUEL FEB 2026
100685	SERVICE CENTER/CITY	101821 5300	\$ 16.39		STMT/02-26	February 2026 Equipment Repair parts
100685	SERVICE CENTER/CITY	101830 5260	\$ 10,632.33		STMT/02-2026	UNLEADED AND DIESEL FUEL FEB 2026
100685	SERVICE CENTER/CITY	101830 5300	\$ 3,011.99		STMT/02-26	February 2026 Equipment Repair parts
100685	SERVICE CENTER/CITY	101845 5260	\$ 316.08		STMT/02-2026	UNLEADED AND DIESEL FUEL FEB 2026
100685	SERVICE CENTER/CITY	101847 5300	\$ 31.52		STMT/02-26	February 2026 Equipment Repair parts
100685	SERVICE CENTER/CITY	651890 5260	\$ 559.16		STMT/02-2026	UNLEADED AND DIESEL FUEL FEB 2026
100685	SERVICE CENTER/CITY	651890 5300	\$ 81.00		STMT/02-26	February 2026 Equipment Repair parts
103730	SIGN SOLUTIONS USA	101830 5320	\$ 754.86		422269	Sign parts
104461	Skandisk	208851 5472	\$ 213.60		014800	CVB-Promotional Items
104460	Snow Wheel System	101830 5300	\$ 2,686.00		10390	Snow Go Wheels
104308	Society of Governmen	208 1370	\$ 133.34		8772	CVB - SGMP Renewal (04/23/26-04/23/27)
104308	Society of Governmen	208851 5471	\$ 266.66		8772	CVB - SGMP Renewal (04/23/26-04/23/27)
103481	STERICYCLE INC	651890 5360	\$ 241.44		8013733573	Lab recycling
100188	STERLING WATER-MINNE	101803 5420	\$ 19.45		315X04496807	Water softener rental
100728	SURPLUS WAREHOUSE IN	101845 5360	\$ 110.00		09890	recycling
100728	SURPLUS WAREHOUSE IN	651890 5360	\$ 10.00		10106	DISHWASHER SCRAP
103656	SWANSON RENTAL LLC	101830 5300	\$ 250.50		48199	Pressure washer parts and hoses
104462	Swanson's Equipment	101830 5220	\$ 288.40		48206	pressure washer repairs
104462	Swanson's Equipment	101830 5300	\$ 250.50		48199	Pressure washer parts and hoses
103801	TECH CHECK,LLC	101809 5220	\$ 3,095.74		64753	FY26 Aruba gear
103801	TECH CHECK,LLC	101809 5220	\$ 10.13		64787	Airport/Swansson Fields cameras
103801	TECH CHECK,LLC	101809 5300	\$ 2,583.17		64753	FY26 Aruba gear
103801	TECH CHECK,LLC	101809 5310	\$ 113.30		64753	FY26 Aruba gear
103801	TECH CHECK,LLC	651890 5320	\$ 3,995.46		64752	Cameras for old Wastewater Plant
101406	TEMPLER/THOMAS	651890 5080	\$ 250.00		033026	Safety boot reimbursement TT
100165	ULTIMATE SAFETY CONC	101821 5200	\$ 275.82		218216	Cal gas
100165	ULTIMATE SAFETY CONC	101821 5370	\$ 300.00		221729	Monitor service training and travel
103660	VALIANT/LESLIE	101801 5370	\$ 58.00		03132026	LMC City Day on the Hill Reimbursements
104447	Vehicle Response	101821 5370	\$ 900.00		2131	EV Training
100951	VIGIL/RUDY	101841 5370	\$ 387.36		032426	Reimbursement for MACTA Meeting
100777	VIKING COCA-COLA BOT	101845 5200	\$ 803.00		3816820	Concessions
100798	WEST CENTRAL ELECTRI	651890 5200	\$ 26.90		1304679-0001-01	Fuses

# Vendor Payment Listing

March 12, 2026 Through April 2, 2026



VENDOR	VENDOR NAME	ACCOUNT	AMOUNT	CHECK NO	INVOICE	INVOICE DESCRIPTION
100798	WEST CENTRAL ELECTRI	651890 5300	\$ 194.82		1304837-0001-01	RWW 3 fuses
100808	WEST CENTRAL TROPHIE	101809 5490	\$ 25.00		10718	Name Tags - J. Johnson
102689	WILLMAR AUTO VALUE	101 1350	\$ 392.43		22601244	battery's
102689	WILLMAR AUTO VALUE	101 1350	\$ 10.98		22601264	Light Bulb
102689	WILLMAR AUTO VALUE	101 1350	\$ 23.96		22601482	H3 Bulbs
102689	WILLMAR AUTO VALUE	101 1350	\$ 17.98		22602750	Light Bulb, zip ties
102689	WILLMAR AUTO VALUE	101 1350	\$ 201.46		22602961	Battery, Brake line
102689	WILLMAR AUTO VALUE	101 1350	\$ 268.99		22603841	Fuel pump
102689	WILLMAR AUTO VALUE	101807 5300	\$ 297.06		22601523	Front Brake caliper, pads, rotors
102689	WILLMAR AUTO VALUE	101807 5300	\$ (74.08)		22601654	Core Return
102689	WILLMAR AUTO VALUE	101820 5300	\$ 115.43		22604327	Alternator
102689	WILLMAR AUTO VALUE	101830 5200	\$ 3.79		22602750	Light Bulb, zip ties
102689	WILLMAR AUTO VALUE	101830 5300	\$ 9.29		22596241	Fuel Filter
102689	WILLMAR AUTO VALUE	101830 5300	\$ 37.75		22602047	Air Filter
102689	WILLMAR AUTO VALUE	101830 5300	\$ 10.55		22602961	Battery, Brake line
102689	WILLMAR AUTO VALUE	101830 5300	\$ 44.93		22603331	Light, pigtail, zipties
102689	WILLMAR AUTO VALUE	101830 5300	\$ 69.99		22603655	Fuel pressure sensor
102689	WILLMAR AUTO VALUE	101845 5220	\$ 40.96		22603486	Washers and Fastners
102689	WILLMAR AUTO VALUE	101845 5220	\$ 43.96		22603797	Parts
102689	WILLMAR AUTO VALUE	101845 5300	\$ 27.96		22603709	Bearing
102689	WILLMAR AUTO VALUE	651890 5200	\$ 6.49		22601691	Fuses
100812	WILLMAR CHAMBER OF C	208850 5200	\$ 17.72		59764	CVB-Credit Card Jan 2026
100812	WILLMAR CHAMBER OF C	208850 5200	\$ 37.73		59765	CVB-Credit Card Feb 2026
100812	WILLMAR CHAMBER OF C	208850 5210	\$ 32.23		59764	CVB-Credit Card Jan 2026
100812	WILLMAR CHAMBER OF C	208850 5210	\$ 42.02		59765	CVB-Credit Card Feb 2026
100812	WILLMAR CHAMBER OF C	208850 5270	\$ 40.00		59761	CVB- January rent, mail, cleaning
100812	WILLMAR CHAMBER OF C	208850 5270	\$ 40.00		59762	CVB- Rent/Mail/Monthly Cleaning
100812	WILLMAR CHAMBER OF C	208850 5290	\$ 51.90		010326	CVB-Credit Card Dec 2025
100812	WILLMAR CHAMBER OF C	208850 5290	\$ 52.50		59761	CVB- January rent, mail, cleaning
100812	WILLMAR CHAMBER OF C	208850 5290	\$ 52.50		59762	CVB- Rent/Mail/Monthly Cleaning
100812	WILLMAR CHAMBER OF C	208850 5290	\$ 20.00		59764	CVB-Credit Card Jan 2026
100812	WILLMAR CHAMBER OF C	208850 5290	\$ 20.00		59765	CVB-Credit Card Feb 2026
100812	WILLMAR CHAMBER OF C	208850 5360	\$ 111.47		59761	CVB- January rent, mail, cleaning
100812	WILLMAR CHAMBER OF C	208850 5360	\$ 111.47		59762	CVB- Rent/Mail/Monthly Cleaning
100812	WILLMAR CHAMBER OF C	208850 5370	\$ 53.80		59764	CVB-Credit Card Jan 2026
100812	WILLMAR CHAMBER OF C	208850 5370	\$ 335.10		59765	CVB-Credit Card Feb 2026
100812	WILLMAR CHAMBER OF C	208850 5380	\$ 291.55		59764	CVB-Credit Card Jan 2026
100812	WILLMAR CHAMBER OF C	208850 5400	\$ 247.80		010326	CVB-Credit Card Dec 2025
100812	WILLMAR CHAMBER OF C	208850 5400	\$ 363.89		59764	CVB-Credit Card Jan 2026
100812	WILLMAR CHAMBER OF C	208850 5400	\$ 139.99		59765	CVB-Credit Card Feb 2026
100812	WILLMAR CHAMBER OF C	208850 5610	\$ 37.69		010326	CVB-Credit Card Dec 2025
100812	WILLMAR CHAMBER OF C	208850 5610	\$ 732.45		59764	CVB-Credit Card Jan 2026
100812	WILLMAR CHAMBER OF C	208851 5471	\$ 29.00		010326	CVB-Credit Card Dec 2025
100812	WILLMAR CHAMBER OF C	208851 5471	\$ 18.30		59765	CVB-Credit Card Feb 2026
100812	WILLMAR CHAMBER OF C	208851 5472	\$ 200.00		010326	CVB-Credit Card Dec 2025
100812	WILLMAR CHAMBER OF C	208851 5472	\$ 908.86		59764	CVB-Credit Card Jan 2026
100812	WILLMAR CHAMBER OF C	208851 5472	\$ 1,720.28		59765	CVB-Credit Card Feb 2026
103454	WILLMAR ROTARY CLUB	208851 5474	\$ 2,000.00		02172026	Explore Willmar Lakes Area - RR Sponsorship
		Total	\$ 1,398,340.51			

# Vendor Payment Listing

March 12, 2026 Thorough April 2, 2026



VENDOR	NAME	INVOICE	CHECK NO	INVOICE NET	INVOICE DESCRIPTION
102365	CARDMEMBER SERVICE	STMT/02-26	646	15,829.74	Old National Bank Credit Card STMT February
100467	CENTERPOINT ENERGY	STMT/02-26	647	35,142.84	Natural Gas February 2026
100492	MN DEPT OF REVENUE	STMT/03-26	648	2,983.93	Sales and Fuel Tax
100467	CENTERPOINT ENERGY	STMT/02-2026	649	16,740.34	NATURAL GAS FEB 2026
			Total	70,696.85	



**City Council Action Request**

<b>Council Meeting Date:</b>	April 6, 2026	<b>Agenda Item Number:</b>	5.M.
<b>Agenda Section:</b>	Consent Items	<b>Originating Department:</b>	Administration
<b>Resolution:</b>	No	<b>Prepared By:</b>	Allie Paulsen, Administrative Assistant
<b>Ordinance:</b>	No	<b>Presented By:</b>	Leslie Valiant, City Administrator
<b>Item:</b>	Airport Commission and Human Rights Commission Applicants		

**RECOMMENDED ACTION:**

For Council consideration: Ron Buchanan’s application to the Airport Commission, and the applications of Sarah Vasquez and Sarah Kretschmann to the Human Rights Commission.

**OVERVIEW:**

Mayor Reese has put forth the application of Ron Buchanan for the Airport Commission, along with the applications of Sarah Vasquez and Sarah Kretschmann for the Human Rights Commission, for Council review.

**BUDGETARY/FISCAL ISSUES:**

**ALTERNATIVES TO CONSIDER:**

**ATTACHMENTS:**

1. Buchanan, Ron Airport Commission
2. Vasquez, Sarah HRC
3. Kretschmann, Sarah HRC

# APPLICATION FOR APPOINTMENT TO CITY BOARD/COMMITTEE/COMMISSION ('22)

[Print](#) [Del](#)

**Submitted by:** Ron Buchanan

**Submitted On:** 2026-03-23 11:33:41

**Submission IP:** 173.40.41.191 (172.31.23.70)  
proxy-IP (raw-IP)

**Status:** Open

**Priority:** Normal

**Assigned To:** Allie Paulsen

**Due Date:** Open



## APPLICATION FOR APPOINTMENT TO CITY BOARD/COMMITTEE/COMMISSION

333 Southwest 6th Street, Willmar, MN 56201 | 320-235-8311 | Fax: 320-235-4917

Please indicate the Board/Committee(s)/Commission(s) to which you are interested in being appointed. You may select more than one.

\* Please indicate the Board/Committee(s)/Commission(s) to which you are interested in being appointed. You may select more than one.

- Airport Commission (meets monthly)
- Cable Advisory Board (meets as needed)
- Charter Commission (meets as needed)
- Park and Recreation Board
- City/County Economic Development Operations Board (meets monthly)
- Human Rights Commission (meets as needed)
- Municipal Utilities Commission (meets bi-monthly)
- Pioneerland Library System Board (meets monthly)
- Planning Commission (meets bi-monthly)
- Police Civil Service Commission (meets first Monday in February each year and on as-needed basis thereafter)
- Willmar Convention and Visitors Bureau
- Ad hoc Task Forces (will be posted and will meet on an as-needed basis)
- Zoning Appeals Board
- Downtown Willmar (DTW)

If you are currently in this Board/Committee/Commission, are you applying for reappointment to serve another term?

- Yes
- No, I have not served this Board/Committee/Commission

### APPLICANT INFORMATION

Date	* First Name	* Last Name
03/23/2026	Ron	Buchanan

Format: MM/DD/YYYY

**\* Address**

412 13th Street Southeast

**\* City**

Willmar

---

**\* Phone**

816-806-4670

**\* Email**

rbuchanan1945@gmail.com

---

Phone

Email

**\* What prompted you to make application for a citizen committee?**

I have been a pilot for 35 years. I thought I may be of some help to this commission based on the number of years I have been in the aviation industry

---

**\* Briefly tell us why you want to serve on this Board/Committee/Commission:**

See above answer

---

**\* List any special background or experience you have which would be helpful to this Board/Committee/Commission:**

I have been a commercial pilot for 35 years. Most of those years I have been based here in Willmar

---

**\* List your educational background**

2 years of college

---

**\* List any social, fraternal, patriotic, governmental, or service organizations, which you have or currently are serving on:**

None

---

**\* If you are employed, please provide the name and address of your employer and your position:**

Retired

---

# APPLICATION FOR APPOINTMENT TO CITY BOARD/COMMITTEE/COMMISSION ('22)

[Print](#) [Del](#)

**Submitted by:** Sarah Vasquez

**Submitted On:** 2026-03-26 14:35:07

**Submission IP:** 172.59.188.228 (172.31.64.91)  
proxy-IP (raw-IP)

**Status:** Open

**Priority:** Normal

**Assigned To:** Allie Paulsen

**Due Date:** Open



## APPLICATION FOR APPOINTMENT TO CITY BOARD/COMMITTEE/COMMISSION

333 Southwest 6th Street, Willmar, MN 56201 | 320-235-8311 | Fax: 320-235-4917

Please indicate the Board/Committee(s)/Commission(s) to which you are interested in being appointed. You may select more than one.

\* Please indicate the Board/Committee(s)/Commission(s) to which you are interested in being appointed. You may select more than one.

- Airport Commission (meets monthly)
- Cable Advisory Board (meets as needed)
- Charter Commission (meets as needed)
- Park and Recreation Board
- City/County Economic Development Operations Board (meets monthly)
- Human Rights Commission (meets as needed)
- Municipal Utilities Commission (meets bi-monthly)
- Pioneerland Library System Board (meets monthly)
- Planning Commission (meets bi-monthly)
- Police Civil Service Commission (meets first Monday in February each year and on as-needed basis thereafter)
- Willmar Convention and Visitors Bureau
- Ad hoc Task Forces (will be posted and will meet on an as-needed basis)
- Zoning Appeals Board
- Downtown Willmar (DTW)

If you are currently in this Board/Committee/Commission, are you applying for reappointment to serve another term?

- Yes
- No, I have not served this Board/Committee/Commission

### APPLICANT INFORMATION

Date	* First Name	* Last Name
03/26/2026	Sarah	Vasquez

Format: MM/DD/YYYY

**\* Address**

1337 24th St NW

**\* City**

Willmar

---

**\* Phone**

(320) 522-3906

Phone

**\* Email**

sarah.vasquez@go.ridgewater.edu

Email

---

**\* What prompted you to make application for a citizen committee?**

I understand that a board vacancy may be opening up in the near future.

---

**\* Briefly tell us why you want to serve on this Board/Committee/Commission:**

I would consider it a privilege to serve as a voice for my community. Furthermore, I view this as an invaluable opportunity to grow as a leader while contributing to the commission's mission.

---

**\* List any special background or experience you have which would be helpful to this Board/Committee/Commission:**

I believe my experience as the Multicultural Club President at Ridgewater College makes me well-prepared to serve as a voice for our community on this board.

---

**\* List your educational background**

I am currently set to graduate this spring and will immediately begin pursuing my bachelor's degree.

---

**\* List any social, fraternal, patriotic, governmental, or service organizations, which you have or currently are serving on:**

Multicultural Club at Ridgewater College.

---

**\* If you are employed, please provide the name and address of your employer and your position:**

I am a full time student and am not employed.

---

# APPLICATION FOR APPOINTMENT TO CITY BOARD/COMMITTEE/COMMISSION ('22)

[Print](#) [Del](#)

**Submitted by:** Sarah Kretschmann

**Submitted On:** 2026-04-02 14:37:07

**Submission IP:** 173.40.41.93 (172.31.27.33)  
proxy-IP (raw-IP)

**Status:** Open

**Priority:** Normal

**Assigned To:** Allie Paulsen

**Due Date:** Open



## APPLICATION FOR APPOINTMENT TO CITY BOARD/COMMITTEE/COMMISSION

333 Southwest 6th Street, Willmar, MN 56201 | 320-235-8311 | Fax: 320-235-4917

Please indicate the Board/Committee(s)/Commission(s) to which you are interested in being appointed. You may select more than one.

\* Please indicate the Board/Committee(s)/Commission(s) to which you are interested in being appointed. You may select more than one.

- Airport Commission (meets monthly)
- Cable Advisory Board (meets as needed)
- Charter Commission (meets as needed)
- Park and Recreation Board
- City/County Economic Development Operations Board (meets monthly)
- Human Rights Commission (meets as needed)
- Municipal Utilities Commission (meets bi-monthly)
- Pioneerland Library System Board (meets monthly)
- Planning Commission (meets bi-monthly)
- Police Civil Service Commission (meets first Monday in February each year and on as-needed basis thereafter)
- Willmar Convention and Visitors Bureau
- Ad hoc Task Forces (will be posted and will meet on an as-needed basis)
- Zoning Appeals Board
- Downtown Willmar (DTW)

If you are currently in this Board/Committee/Commission, are you applying for reappointment to serve another term?

- Yes
- No, I have not served this Board/Committee/Commission

### APPLICANT INFORMATION

Date	* First Name	* Last Name
04/02/2026	Sarah	Kretschmann

Format: MM/DD/YYYY

**\* Address**

824 5th St SE

**\* City**

Willmar

---

**\* Phone**

608-333-2604

Phone

**\* Email**

smkretsc@gmail.com

Email

---

**\* What prompted you to make application for a citizen committee?**

Pablo Obregon and Peggy Karsten encouraged me to apply to be a part of the Human Rights Commission.

---

**\* Briefly tell us why you want to serve on this Board/Committee/Commission:**

After being prompted to apply, I looked into the Human Rights Commission and was compelled by the mission to facilitate equal opportunity and improve human relations for all citizens in the City of Willmar. This work is more important than ever in light of the recent rights violations experienced by members of our community during increased immigration enforcement. I would be grateful for the opportunity

---

**\* List any special background or experience you have which would be helpful to this Board/Committee/Commission:**

My work with refugee resettlement, international development and social service non-profits in marketing, development and community engagement has prepared me to support initiatives like this one that empower community leaders to improve human relations for all citizens. My experience includes: Strategic Program Leadership: Proven ability to design and implement programs that equip organizations with best practices in resource management, ensuring long-term viability and mission alignment. Stakeholder Engagement & Collaboration: Skilled in building partnerships across sectors to foster knowledge-sharing and strengthen networks of support. Resource Development & Training: Experienced in developing resources, workshops, and guidance to assist in community engagement and education.

---

**\* List your educational background**

Master of Divinity Luther Seminary Focus: Interfaith Engagement and Ecotheology Bachelor of Arts St. Olaf College Sociology/ Anthropology & Environmental Studies

---

**\* List any social, fraternal, patriotic, governmental, or service organizations, which you have or currently are serving on:**

Ordained as Minister of Word & Service in the Evangelical Lutheran Church in America After four years of seminary education, fulfilling multiple contextual learning requirements, and completing the candidacy process in the ELCA, I was ordained in 2020 as a Deacon. Board Member • Clinton Street Community Center October 2021 - March 2023 Founding board member of the Clinton Street Community Center, an organization investing in the families of Highlandtown in Baltimore, Maryland offering high quality education to young people and supporting newly arrived families Building Inclusive Church Leader (LGBTQ+ Advocacy) Trained to lead churches toward the full welcome, inclusion, and equity of lesbian, gay, bisexual, transgender, queer, intersex and asexual/aromantic (LGBTQIA+) neighbors. Prepare & Enrich Facilitator (Marriage and Relationship Support) Completed Healthy Relationship facilitator training through Prepare & Enrich to provide counsel and support to couples in their pursuit of healthy relationships.

---

**\* If you are employed, please provide the name and address of your employer and your position:**

Communications Manager • Church Property Resource Hub - A Project of the ELCA • August 2025 - Present Evangelical Lutheran Church in America, 8765 W Higgins Rd Chicago, IL 60631 Key responsibilities - Manage the digital presence of the Church Property Resource Hub - Moderate, support and publicize the Resource Hub's support forum - Support collection and promotion of success stories, creation and curation of resources, and development of training and education opportunities for synod and congregational leaders.

---

# MOTHLY BUILDING REPORT MARCH 2026

Permit Number	Address	Permit Type	Permit Work Class	Permit Issue Date	Permit Valuation	Parcel Number
BLDR-2026-0329	2204 Williams Pkwy SWWillmar, MN 56201	Residential	Re-Roof	3/3/2026	\$14,000.00	95-715-1910
BLDR-2026-0328	308 Terrace Dr SWWillmar, MN 56201	Residential	Alteration/Remodel	3/3/2026	\$27,767.00	95-330-0340
MECH-2026-0020	1605 1st St SWWillmar, MN 56201	Commercial Mechanical	Mechanical	3/4/2026	\$10,200.00	95-923-8640
BLDC-2026-0073	1630 Hwy 12 EWillmar, MN 56201	Commercial	Alteration/Remodel	3/4/2026	\$300,000.00	95-913-1028
BLDR-2026-0331	812 14th Ave SWWillmar, MN 56201	Residential	Alteration/Remodel	3/6/2026	\$10,000.00	95-750-0700
BLDR-2026-0330	321 7th St SWWillmar, MN 56201	Residential	Deck	3/6/2026	\$1,876.90	95-003-4760
BLDC-2026-0077	1920 Hwy 12 EWillmar, MN 56201	Commercial	New	3/6/2026	\$4,220,000.00	95-913-0990
RMECH-2026-0145	511 19th St SEWillmar, MN 56201	Residential Mechanical	Mechanical	3/9/2026	\$9,355.00	95-095-0180
CPLUMB-2026-0020	1601 Hwy 12 EWillmar, MN 56201	Commercial Plumbing	Plumbing	3/9/2026	\$15,000.00	95-914-1650
BLDR-2026-0332	505 28th St SEWillmar, MN 56201	Residential	Single Family Dwelling	3/18/2026	\$375,000.00	95-882-0570
BLDC-2026-0079	3504 30th St NEWillmar, MN 56201	Commercial	Demolition	3/20/2026	\$296,000.00	95-936-9120
BLDR-2026-0334	716 Irene Ave SEWillmar, MN 56201	Residential	Re-Roof	3/20/2026	\$6,000.00	95-662-0060
BLDR-2026-0333	808 Irene Ave SEWillmar, MN 56201	Residential	Re-Roof	3/20/2026	\$4,250.00	95-662-0030
BLDR-2026-0339	2007 20th Ave SWWillmar, MN 56201	Residential	Re-Roof	3/31/2026	\$6,750.00	95-885-0010
BLDR-2026-0340	320 High Ave NEWillmar, MN 56201	Residential	Demolition	3/31/2026	\$100.00	95-730-0310

Permits                    15  
Valuation                    \$5,296,298.90



**City Council Action Request**

<b>Council Meeting Date:</b>	April 6, 2026	<b>Agenda Item Number:</b>	9.A.
<b>Agenda Section:</b>	Regular Business	<b>Originating Department:</b>	Administration
<b>Resolution:</b>	No	<b>Prepared By:</b>	
<b>Ordinance:</b>	No	<b>Presented By:</b>	
<b>Item:</b>	State of the City Address - Mayor Reese		

**RECOMMENDED ACTION:**

**OVERVIEW:**

**BUDGETARY/FISCAL ISSUES:**

**ALTERNATIVES TO CONSIDER:**

**ATTACHMENTS:**

None



### City Council Action Request

<b>Council Meeting Date:</b>	April 6, 2026	<b>Agenda Item Number:</b>	9.B.
<b>Agenda Section:</b>	Regular Business	<b>Originating Department:</b>	Administration
<b>Resolution:</b>	No	<b>Prepared By:</b>	Leslie Valiant, City Administrator
<b>Ordinance:</b>	No	<b>Presented By:</b>	Marv Calvin, KCED Interim Executive Director, Sheri Wegner, KCED Economic Development Manager
<b>Item:</b>	Kandiyohi County Economic Development Housing Study Introduction		

**RECOMMENDED ACTION:**  
Information

**OVERVIEW:**

The most recent Kandiyohi County housing study was completed in December 2022. At that time, a group of key stakeholders—including the Willmar Area Community Foundation, Kandiyohi County Economic Development, City of Willmar, Kandiyohi County, Jennie-O Turkey Store, Willmar Lakes Area Chamber of Commerce, and Mid-Minnesota Development—committed to contributing \$1,000 annually to the Kandiyohi County Horizons Fund.

The purpose of this commitment is to support local Census preparation efforts and to provide seed funding for ongoing housing studies (or other mutually agreed-upon critical data initiatives), ensuring that no single entity bears the burden of securing the full funding in any given budget year.

**BUDGETARY/FISCAL ISSUES:**  
N/A

**ALTERNATIVES TO CONSIDER:**

**ATTACHMENTS:**

1. 2026 Housing study Introduction presentation
2. Kandiyohi County - updated Comprehensive housing study proposal 2026



# KANDIYOHI COUNTY HOUSING STUDY 2026



KANDIYOHI COUNTY  
ECONOMIC DEVELOPMENT



## Housing Market Analysis for Willmar, Minnesota

Prepared for:

**Kandiyohi County and City of Willmar Economic Development Commission**

Prepared by:

**Viewpoint Consulting Group, Inc.**

Date:

**December 6, 2022**

The last  
comprehensive  
Housing Study  
was conducted  
in 2023



**MAKE CONNECTIONS. IMPACT YOUR COMMUNITY.**

The Willmar Lakes Area Vision 2040 connects the dreamers and the doers with the tools they need to make a difference in our communities. Making dreams a reality!

In Partnership with Vision 2040 we have initiated the 2026 Kandiyohi County Housing study with View Point Consulting group.

# Priorities for the study

Demographic Trends and Projections

Employment Trends

Housing Characteristics

For-Sale Market Analysis

Rental Market Analysis

Senior Housing Market Analysis

Disability Housing

# Questions being asked in the Communities

Are there any key housing issues that have been brought to your attention by board members or other people in the community that you have been in contact with?

# Questions being asked in the Communities

Who would be the best person to talk to regarding new businesses or business expansions that are being proposed in Willmar and elsewhere in the County that could lead to job growth?

# Questions being asked in the Communities

Besides Bethesda Stoneridge and The Crossings of Willmar, are there any new subdivisions, apartment developments, or senior housing that are being discussed to be built in the county?

# Questions being asked in the Communities

Regarding housing designated for people with disabilities, who would be good contacts to interview?

# Completed Study

The intention is a completed study before year end.

To create single page files for each community with a dashboard of needs in addition to the full report.



January 21, 2026

Sheri Wegner  
Economic Development Manager  
Kandiyohi County Economic Development  
1601 US-12  
Willmar, MN 56201

**Re: Contract/Proposal for a comprehensive housing needs analysis for Kandiyohi County, Minnesota**

This contract for professional services is made between Viewpoint Consulting Group, Inc. (“Viewpoint”) and the Kandiyohi County Economic Development (the “Client”). The professional service outlined in this contract is a comprehensive housing needs analysis. The analysis would update a previous countywide analysis completed in 2023 by Viewpoint Consulting Group, Inc. The updated analysis would examine demographic and employment trends and current housing market conditions in Kandiyohi County to determine the market potential for developing different types of owned and rented housing through 2035. The analysis would provide detailed recommendations on the housing types identified as being needed over the next five years. The housing study would be presented in one combined report that includes chapters for each community.

To complete the comprehensive housing needs analysis, primary and secondary data would be examined. Primary research includes surveys of existing owned and rented housing properties in the county and interviews with housing professionals and government agency staff familiar with local employment and housing issues. Secondary data is obtained from sources such as the Census Bureau, ESRI (national demographics provider), and MN Dept. of Employment and Economic Development.

A detailed Scope of Services on the following pages outlines the specific tasks that would be undertaken to conduct the comprehensive housing needs analysis.

**Scope of Services**

**A. Demographic Trends and Projections**

1. Compile and analyze information on population and household growth trends and projections (1990 to 2040) in the following communities in Kandiyohi County:

Atwater	Prinsburg
Blomkest	Raymond
Kandiyohi	Regal
Lake Lillian	Spicer
New London	Sunburg
Pennock	Willmar

2. Compile demographic information on Willmar and the remainder of the county on:
  - a. population age distribution
  - b. household incomes by age of householder
  - c. household tenure (owners/renters)
  - d. Household income by tenure
  - e. household type
  - f. household sizes
3. Examine student enrollment trends and projections at Ridgewater College.

**B. Employment Trends**

1. Examine county data on resident employment (based on place of residence).
2. Examine county data on covered employment (based on location of jobs).
3. Interview economic development specialists with the City of Willmar and Kandiyohi County regarding business growth trends, potential new businesses, and economic conditions.
4. Interview larger local employers regarding total number of employees, where employees live, and housing needs of employees.
5. Examine work commuting patterns for each of the communities in the county.

**C. Housing Characteristics**

1. Examine census data on age of housing stock in each community in the county.
2. Compile residential building permit data since 2010 in each community in the county.
3. Examine census data on housing cost burden by tenure in Willmar and the remainder of the county.
4. Examine census data on total housing units by tenure and structure type in each community in the county.
5. Interview housing professionals regarding housing conditions in each community in the county.

**D. For-Sale Market Analysis**

1. Analyze housing value trends in each community from data provided by the county assessors' office.
2. Analyze data on the inventory and list price of homes currently for sale; discuss the number of listings affordable to households of varying incomes.
3. Inventory actively marketed single-family subdivisions in the county; collect data on available lots, lot sizes, sale prices, lot absorption, and housing types.
4. Inventory for-sale townhome developments in the county; collect data on the number of units, year built, unit types, sale prices, and housing types.
5. Identify proposed for-sale housing developments in the county.
6. Interview real estate sales agents, developers, and other housing professionals regarding demand for additional housing in Willmar and other communities in the county, buyer profiles, desired housing types and price range, unmet market niches, and the physical condition of existing homes.

**E. Rental Market Analysis**

1. Examine census data on total units in Willmar and the remainder of the county by number of bedrooms and gross rent.
2. Inventory larger multifamily rental buildings in the county, including subsidized (e.g. Section 8), affordable (e.g. Section 42 Tax Credit), market rate buildings, and student-oriented buildings. Collect information on year built, number of units, rents, and occupancy rate.
3. Identify pending rental developments in the county.
4. Interview rental property owners and managers and other housing professionals regarding rental housing needs, and the level of demand for accessible units.

**F. Senior Housing Market Analysis**

1. Inventory senior housing developments in the county, including subsidized, affordable, and market rate developments. Collect information on Service level (active adult, independent, assisted living, memory care), year built, number of units, and occupancy rate.
2. Identify pending senior housing developments in the county.
3. Interview managers of senior housing developments and other professionals in the senior housing industry regarding senior housing needs in Willmar and other communities in the county.

**G. Disability Housing**

1. Examine census data on the number of people in the county with disabilities, including information on disabilities by age, type of disability, and work status.
2. Inventory homes in the county that provide housing to disabled populations, such as adult foster care, home and community-based services, and community residential facilities.
3. Interview staff at Kandiyohi County Health & Human Services and other organizations that provide disabled populations with service and housing to maintain their independence; discuss availability of housing, the need for additional housing, appropriate housing types, appropriate locations for housing, the level of need by type of disability.

**H. Conclusions and Recommendations**

1. Summarize key findings from the demographic, employment, and housing analysis sections and discuss the implications on housing demand throughout Kandiyohi County – including the affordability of existing and new construction homes for households at varying incomes.
2. Calculate housing demand for each community in the county through 2035, including owned and rental housing by various price/rent ranges, senior housing by service level, and housing for disabled individuals.
3. Recommend housing types (new development) to meet unmet demand in each community over the next five years; include information on number of lots/units, types of housing, prices/rents, accessibility, and other key housing features.
4. Discuss appropriate locations for housing for disabled people and seniors and the ability to age in place at the various recommended housing types.
5. Estimate the number of homes that would become available for purchase by moderate income households if the recommended number of for-sale and senior housing units are built.
6. Present the findings in a single report containing one-page summaries and chapters for each community in the county.

### **Meetings and Report Preparation**

Viewpoint Consulting Group, Inc. would begin the housing needs analysis with a “kick-off meeting” with the client by phone to discuss the objectives of the updated housing needs analysis, key information needed from the client, and timing of the analysis. Viewpoint Consulting Group would visit Kandiyohi County during the analysis. The housing needs analysis would be provided to the client in an electronic PDF copy.

### **Timing and Cost of Services**

The housing needs assessment outlined in the scope of services will be completed in draft form within 150 days of authorization to proceed. The cost for staff time to complete the scope of services will be Thirty-Nine Thousand Four Hundred Dollars (\$39,400.00). The contract amount is due within 15 days of receipt of an invoice showing completion of the analysis.

### **Disclaimer & Liability**

Certain information and statistics contained in Viewpoint’s report, which may be used as the basis for conclusions contained therein, will be furnished by other independent sources. While Viewpoint believes the information to be reliable, it has not been independently verified by Viewpoint and Viewpoint assumes no responsibility for its accuracy. The conclusions in Viewpoint's report are based on Viewpoint's best judgment and Viewpoint disclaims any express or implied warranty of assurance or representation that the projections or conclusions will be realized as stated. Results of any project may vary for any number of reasons including, but not limited to, changing market conditions, changes in the facts that were the basis of conclusions in Viewpoint's report, or other unforeseen circumstances.

Notwithstanding anything to the contrary herein, Viewpoint shall not be responsible for, and shall not pay, any amount of incidental, consequential or other indirect damages, whether based on lost revenue or otherwise, regardless of whether Viewpoint was advised of the possibility of such losses in advance. In no event shall Viewpoint's liability hereunder exceed the amount of fees paid by the Client, regardless of whether the Client's claim is based on contract, tort, strict liability, product liability or otherwise.

### **General Provisions**

If any provision of this Agreement is held unenforceable by a court of competent jurisdiction, that provision shall be severed and shall not affect the validity or enforceability of the remaining provisions.

This Agreement shall be governed by and construed in accordance with the internal laws (and not the laws of conflicts) of the State of Minnesota.

This Agreement constitutes the complete Agreement and sets forth the entire understanding and Agreement of the parties as to the subject matter of this Agreement and supersedes all prior discussions and understandings in respect to the subject of this Agreement, whether written or oral.

If there is any dispute or controversy between the parties arising out of or relating to this Agreement, the parties agree that such dispute or controversy will be arbitrated in accordance with proceedings

under American Arbitration Association rules, and such arbitration will be the exclusive dispute resolution method under this Agreement. The decision and award determined by such arbitration will be final and binding upon both parties. All costs and expenses, including reasonable attorney's fees and expert's fees, of all parties incurred in any dispute which is determined and/or settled by arbitration pursuant to this Agreement will be borne by the party determined to be liable in respect of such dispute; provided, however, that if complete liability is not assessed against only one party, the parties will share the total costs in proportion to their respective amounts of liability so determined. Except where clearly prevented by the area in dispute, both parties agree to continue performing their respective obligations under this Agreement until the dispute is resolved. Any arbitration necessary pursuant to this Agreement shall occur in the County of Hennepin, State of Minnesota.

The foregoing notwithstanding, in the event the Client fails to pay Viewpoint as provided for herein, Viewpoint may take action to recover amounts owing in Hennepin County District Court. The Client acknowledges that it will be responsible for all costs of collection including, but not limited to, court costs and attorneys fees.

No modification, termination or attempted waiver of this Agreement, or any provision thereof, shall be valid unless in writing signed by the party against whom the same is sought to be enforced.

If this proposal meets with your approval, please sign and return a copy to Viewpoint Consulting Group and we will begin working with you on this assignment.

Agreed to this \_\_\_\_\_ day of \_\_\_\_\_ 2026.

Viewpoint Consulting Group, Inc.



\_\_\_\_\_  
Jay Thompson  
President

Kandiyohi County Economic Development

\_\_\_\_\_  
By:  
Its:



## City Council Action Request

<b>Council Meeting Date:</b>	April 6, 2026	<b>Agenda Item Number:</b>	9.C.
<b>Agenda Section:</b>	Regular Business	<b>Originating Department:</b>	Recreation
<b>Resolution:</b>	Yes	<b>Prepared By:</b>	Rob Baumgarn, Recreation Director
<b>Ordinance:</b>	No	<b>Presented By:</b>	Shane Stefanick, Public Works Director
<b>Item:</b>	Approving the plans and specifications and authorizing advertisement for bids for the Robbins Island Amphitheater Project.		

**RECOMMENDED ACTION:**

Adopt a resolution approving the plans and specifications and authorizing advertisement for bids for the Robbins Island Amphitheater Project.

**OVERVIEW:**

In August 2023, the City of Willmar entered into an agreement with the Willmar Rotary Club for the development of an amphitheater (the “Project”) at Robbins Island Regional Park. The City has successfully secured two grants from the Greater Minnesota Regional Parks and Trails Commission (Legacy) totaling \$2,632,513 to support the Project.

Under the terms of the agreement, the Willmar Rotary Club is responsible for completing the architectural and engineering design, incorporating feedback and direction from the City into the final construction plans and bidding specifications. Upon completion of the design phase, the project will transition to the City for bidding and construction.

Engan Associates, Rotary representatives, and City staff have reviewed the plans, and it is the collective recommendation to present the Project to the City Council for approval to proceed with bidding.

**BUDGETARY/FISCAL ISSUES:**

Funding for the Project is provided through grants from the Greater Minnesota Regional Parks and Trails Commission (Legacy) and contributions from the Willmar Rotary Club.

**ALTERNATIVES TO CONSIDER:**

Don’t approve the plans for the project.

**ATTACHMENTS:**

1. Resolution for Bids for Robbins Island Amphitheater Project
2. Robbins Island Amphitheater Plans

**RESOLUTION NO. \_\_\_\_**

**RESOLUTION APPROVING TO ADOPT A RESOLUTION APPROVING THE PLANS AND SPECIFICATIONS AND AUTHORIZING ADVERTISEMENT FOR BIDS FOR THE ROBBINS ISLAND AMPHITHEATER PROJECT**

Motion By: \_\_\_\_\_ Second By: \_\_\_\_\_

BE IT RESOLVED by the City Council of the City of Willmar to adopt a resolution approving the plans and specifications and authorizing advertisement for bids for the Robbins Island Amphitheater Project.

Dated this 6th day of April 2026

\_\_\_\_\_  
Douglas E. Reese, Mayor

Attest:

\_\_\_\_\_  
CITY CLERK

# ROBBINS ISLAND AMPHITHEATER

## WILLMAR, MN



1 PROJECT LOCATION  
G-001 SCALE: N.T.S.

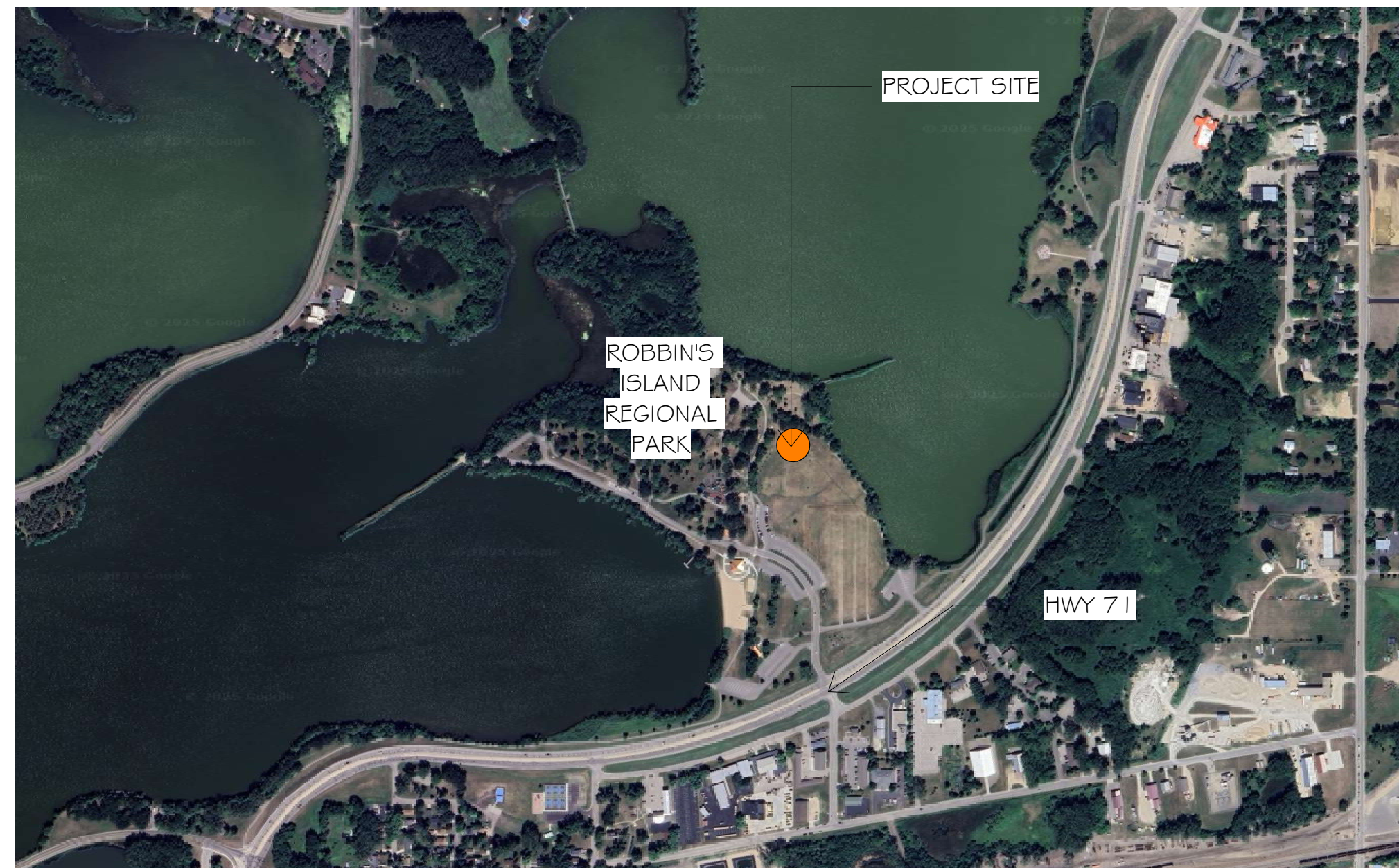

2 SITE MAP  
G-001 SCALE: N.T.S.

DRAWING INDEX		STATUS	DATE
Sheet Number	Sheet Name		
G-001	TITLE SHEET		
G-012	CODE REVIEW		
C-101	SURVEY		
C-121	SITE GRADING PLAN		
C-131	SITE IMPROVEMENT PLAN		
A-131	STAGE LEVEL		
A-134	STAGE LEVEL Copy 1		
A-135	STAGE LEVEL Copy 2		
A-151	ROOF PLAN & DETAILS		
A-161	REFLECTED CEILING PLANS -		
A-200	EXTERIOR ELEVATIONS		
A-201	EXTERIOR ELEVATIONS		
A-202	EXTERIOR PERSPECTIVES		
A-301	MAIN STAGE BUILDING SECTIONS		
A-302	AMPHITHEATRE SECTIONS		
A-311	WALL SECTIONS - EXTERIOR		
A-312	WALL SECTIONS		
A-401	INTERIOR ELEVATIONS		
A-402	INTERIOR ELEVATIONS		
A-501	INTERIOR DETAILS		
A-511	BUILDING DETAILS		
A-531	DOOR, FRAME AND WINDOW TYPES		
A-532	DOOR & WINDOW DETAILS		
A-551	ROOF DETAILS		
A-561	STAIR PLANS AND SECTIONS		
A-591	FIRE DETAILS		
S-1	Structural Sheet Template		
M-1	Mechanical Sheet Template		
E-1	Electrical Sheet Template		



**ENGAN ASSOCIATES**  
ARCHITECTS | INTERIOR DESIGNERS  
shared vision. innovative design.  
311 4th Street SW, P.O. Box 956, Willmar, MN 56201  
320-235-0860 FAX: 320-235-0861 | www.engan.com



Certification & Seal:  
**PRELIMINARY**  
**NOT FOR CONSTRUCTION**

PROJECT # XXX.XX DATE: --  
DRAWN BY: KW CHECKED BY: AME  
OWNER: CLIENT NAME

Revision | Date

ROBBINS ISLAND  
AMPHITHEATER

WILLMAR, MN

TITLE SHEET

G-001

# 2020 MINNESOTA BUILDING CODE REVIEW (IBC)

THE FOLLOWING AREA SOME BUILDING CODE REQUIREMENTS

## CHAPTER 3 USE AND OCCUPANCY CLASSIFICATION

303.6	ASSEMBLY - A-5
304.1	BUSINESS - B
311.3	STORAGE - S-2
CHAPTER 4 SPECIAL DETAILED REQUIREMENT BASED ON OCCUPANCY AND USE	
410	STAGES PLATFORMS AND TECHNICAL PRODUCTION AREAS
410.2	STAGES
410.2.1	STAGE CONSTRUCTION
410.2.1.	STAGE HEIGHT & AREA
410.2.2	TECHNICAL PRODUCTION AREAS: GALLERIES, GRIDIRONS AND CATWALKS
410.2.3	EXTERIOR STAGE DOORS
410.2.5	PROSCENIUM CURTAIN
410.2.6	SCENERY (OWNER INFO-NO SCENERY IS INCLUDED IN THIS PROJECT)
410.2.7	STAGE VENTILATION
410.3.1	TEMPORARY PLATFORM CONSTRUCTION (OWNER INFO)
410.4	DRESSING AND APPURTENANT ROOMS
410.4.1	SEPARATION FROM STAGE THE GREEN ROOM IS TO BE SEPARATED FROM THE STAGE BY A ONE HOUR FIRE BARRIER IN ACCORDANCE WITH 707. STORAGE SPACE IS SEPARATED FROM THE STAGE BY A ONE HOUR FIRE BARRIER.
410.4.2	SEPARATION FROM EACH OTHER THE GREEN ROOM AND STORAGE SPACE ARE NOT CONTIGOUS AND BOTH ARE SEPARATED FROM THE STAGE BY A 1 HR FIRE BARRIER
410.5	MEANS OF EGRESS
410.6	<b>AUTOMATIC SPRINKLER SYSTEMS</b> ARE NOT REQUIRED PER 903.1.1.1. EXEMPTIONS 3 & 4

## CHAPTER 5 GENERAL BUILDING HEIGHTS AND AREAS

### 504.3 ALLOWABLE HEIGHT OF BUILDING

OCCUPANCY CLASSIFICATION	TYPE OF CONST.	SPRINKLED	HEIGHT
A-5	VB	NS	40
S-2	VB	NS	40

### 504.4 ALLOWABLE NUMBER OF STORIES ABOVE GRADE

OCCUPANCY CLASSIFICATION	TYPE OF CONST.	SPRINKLED	NO. OF STORIES
A-5	V5	NS	UNLIMITED
S-2	VB	NS	2

## 506 BUILDING AREA

### 506.02 ALLOWABLE AREA FACTOR

OCCUPANCY CLASSIFICATION	TYPE OF CONST.	ALLOWABLE AREA FACTOR	ACTUAL AREA
A-5	VB	UNLIMITED	2,176
S-2	VB	13,500	741

50

## CHAPTER 6 TYPE OF CONSTRUCTION

### TABLE 601 FIRE RATING REQ.

STRUCTURAL FRAME	VB	- 0 HR
BEARING WALLS	- 0 HR	
NON BEARING WALLS	- 0 HR	
FLOOR CONSTRUCTION	- 0 HR	
ROOF CONSTRUCTION	- 0 HR	

## CHAPTER 8 INTERIOR FINISHES

803.1.2 CLASS A: FLAME SPREAD INDEX 0-25; SMOKEDEVELOPED INDEX 0-450  
CLASS B: FLAME SPREAD INDEX 26-75; SMOKEDEVELOPED INDEX 0-450  
CLASS C: FLAME SPREAD INDEX 75-200; SMOKEDEVELOPED INDEX 0-450

### 803.13 INTERIOR WALL AND CEILING FINISH UNSPRINKLED

VERTICAL EXITS AND EXIT PASSAGEWAYS	A
CORRIDOR	A
ROOMS	C
FLOORS	C

### 804.4.2 FLOORS CLASS III IN GROUPS A

## CHAPTER 9 FIRE PROTECTION SYSTEMS

### 903 AUTOMATIC SPRINKLING SYSTEMS

903.3.2. AN AUTOMATIC SPRINKLING SYSTEM IS NOT REQUIRED WITH OCCUPANCY LESS THAN 300.

### 906.3.1 MAX TRAVEL DISTANCE TO PORTABLE FIRE EXTINGUISHER 75 FEET

### 907 FIRE ALARM SYSTEM IS NOT REQUIRED??

## CHAPTER 10 MEANS OF EGRESS

### 1004.5.4 TABLE OCCUPANT LOAD

	TOTAL SF	RATING	OCCUPANCY	EXITS
STAGE 1	1,550	1.5 NET	104	
STAGE 2	626	1.5 NET	42	
STAGE CIRCULATION	171	-	-	
GREEN ROOM (B)	570	1.5 NET	31	
STORAGE/BACKSTAGE (S-2)	570	300 GROSS	2	

STAGE 1 AND STAGE 2 WILL NOT BE USED AT THE SAME TIME. GREEN ROOM OCCUPANTS WILL BE THE SAME PEOPLE OCCUPYING THE STAGE.

### 1011 STAIRWAYS 44 INCH MIN. CLEAR

### 1012 RAMPS 1:12 MAX SLOPE, 2% MAX CROSS SLOPE, 30" MAX RISE BETWEEN LANDINGS

### 1014 HANDRAILS

### 1015 GUARDS

### 1015.2 EXCEPTION 2 NOT REQUIRED AT STAGE

### 1017 TRAVEL DISTANCE TO EXIT

### TABLE 1017.2 A-5 OCCUPANCY 200'-0" MAX W/OUT SPRINKLER

### 1019 EXIT ACCESS STAIRS & RAMPS

### 1019.2 STAIR NOT REQUIRED TO BE CLOSED

## CHAPTER 14 EXTERIOR WALLS

## CHAPTER 15 ROOF ASSEMBLY

### 1502 ROOF DRAINAGE

## CHAPTER 16 STRUCTURAL DESIGN

## CHAPTER 29 PLUMBING

**STORAGE/BACKSTAGE  
OCCUPANCY S-2  
AREA = 540 SF**

**AMPHITHEATRE  
OCCUPANCY A-5  
AREA=600 SF**

**GREEN ROOM  
OCCUPANCY A-5  
(APPURTENANT)  
AREA = 540 SF**

**MAINSTAGE  
OCCUPANCY A-5  
AREA = 1531 SF**

### 2 CODE PLAN STAGE LEVEL

SCALE: 1/8" = 1'-0"

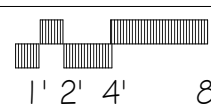

**BUILDING OCCUPANCY & USAGE NARRATIVE:**

- REGULARLY UNOCCUPIED AND SEASONAL: THE GENERAL PUBLIC IS NOT ALLOWED FREE ACCESS INTO THE INTERIOR SPACES OF THE BUILDING ON A DAY TO DAY BASIS. DOORS TO THE INTERIOR SPACES WILL BE LOCKED AND ONLY OPENED FOR SCHEDULED EVENTS. LOCKING THE INTERIOR SPACE DOES NOT ELIMINATE EGRESS FROM THE OPEN AIR STAGES.
  - STAIRS TO STAGE PLATFORM: A LOCKABLE GATE COULD BE PROVIDED FOR THE STAIRWAYS BUT IT WOULD NOT ELIMINATE THE ABILITY OF SOMEONE TO CLIMB THE STAGE AND WOULD ELIMINATE THE SAFEST EGRESS ROUTE FROM THE STAGE.
- CATEGORIES OF USE OF THE BUILDING: WHILE THE BUILDING IS REGULARLY UNOCCUPIED, THE PRIMARY FUNCTION OF THE BUILDING IS ASSEMBLY FOR SCHEDULED EVENTS. THESE EVENTS INHERENTLY WILL FALL INTO TWO CATEGORIES:
  - CATEGORY A: ASSEMBLY OF OCCUPANTS OUTSIDE OF BUILDING PERIMETER.**
    - THE VENUE COULD ATTRACT UP TO 10,000 PEOPLE FOR LARGE CONCERT EVENTS. IN THIS CASE, NO PUBLIC ACCESS TO THE BUILDING IS ALLOWED FOR THE DURATION OF THE EVENT.
    - EVENTS LIKE THESE WILL REQUIRE SECURITY BARRIERS, STAFF, AND/OR OTHER FORMS OF SECURITY AND CROWD CONTROL THAT WILL BE THE RESPONSIBILITY OF THE RENTER OF THE VENUE.
  - CATEGORY B: ASSEMBLY OF OCCUPANTS INSIDE BUILDING PERIMETER.**
    - THE BUILDING CAN BE RENTED AS A VENUE FOR EVENTS LIKE MEETINGS, RELIGIOUS SERVICES, REUNIONS, GRADUATION PARTIES, AND OTHER "SMALLER" GROUP EVENTS.
    - ATTENDANCE FOR CATEGORY B EVENTS IS LIMITED TO OCCUPANCY NUMBER IDENTIFIED IN THE CODE SUMMARY.
      - OCCUPANCY SIGNS SHALL BE INSTALLED IN ALL ROOMS OF THE STRUCTURE.

### FIRE PLAN LEGEND

1 HOUR WALL



**ENGAN ASSOCIATES**  
ARCHITECTS | INTERIOR DESIGNERS  
shared vision. innovative design.  
311 4th Street SW, P.O. Box 956, Willmar, MN 56201  
320-235-0860 FAX: 320-235-0861 | www.engan.com



Certification # Seal:

**PRELIMINARY  
NOT FOR CONSTRUCTION**

PROJECT # XXX,XX DATE: -

DRAWN BY: ??? CHECKED BY: ???

OWNER: CLIENT NAME

Revision Date

ROBBINS ISLAND  
AMPHITHEATER

WILLMAR, MN

CODE REVIEW

G-011



H:\WILL\25X140092\000\CAD\C3D\140092\_C CORR\_F1.dwg 3/25/2026 3:30:05 PM

GRADING LEGEND	
	EXISTING CONTOUR MINOR
	EXISTING CONTOUR MAJOR
	PROPOSED CONTOUR MINOR
	PROPOSED CONTOUR MAJOR

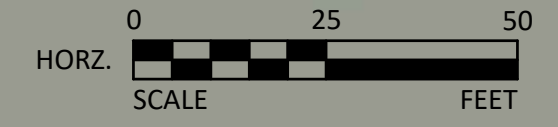

**ENGAN ASSOCIATES**  
 ARCHITECTS | INTERIOR DESIGNERS  
 shared vision. innovative design.  
 311 4th Street SW, P.O. Box 956, Willmar, MN 56201  
 320-235-0860 FAX: 320-235-0861 | www.engan.com



STRUCTURAL ENGINEER  
 Alexandria, MN  
 320.808.4146 | www.AsceEngineering.com

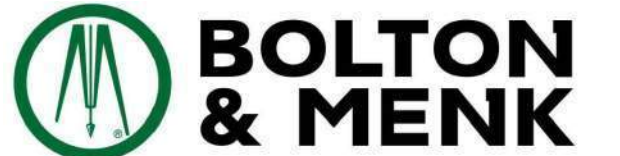

Real People. Real Solutions.



Electrical Consulting Engineers  
 Minneapolis, MN  
 763.486.0965  
 jeff@jbelectricaldesign.com



Certification & Seal:

**PRELIMINARY**

**NOT FOR CONSTRUCTION**

SEALER'S NAME \_\_\_\_\_  
 LIC. NO. XXXXX DATE MM/DD/YYYY

PROJECT # 00-000 DATE: Issue Date  
 DRAWN BY: DTI CHECKED BY: JAV  
 OWNER: CITY OF WILLMAR

Revision	Date

ROBBINS ISLAND  
 AMPHITHEATER

WILLMAR, MN

EXISTING CONDITIONS & REMOVALS  
 140092C001 - Plan Only

C101



**ENGAN ASSOCIATES**  
 ARCHITECTS | INTERIOR DESIGNERS  
 shared vision. innovative design.  
 311 4th Street SW, P.O. Box 956, Willmar, MN 56201  
 320-235-0860 FAX: 320-235-0861 | www.engan.com



STRUCTURAL ENGINEER  
 Alexandria, MN  
 320.808.4146 | www.AsceEngineering.com

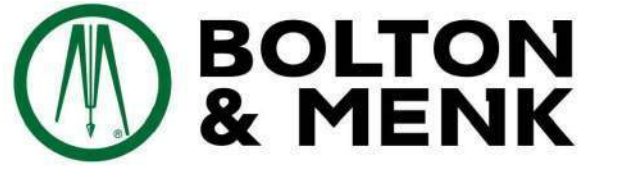

Real People. Real Solutions.



Electrical Consulting Engineers  
 Minneapolis, MN  
 763.486.0965  
 jeff@jbelectricaldesign.com



Certification & Seal:

**PRELIMINARY**

**NOT FOR CONSTRUCTION**

SEALER'S NAME: \_\_\_\_\_ LIC. NO.: XXXXX DATE: MM/DD/YYYY

PROJECT # 00-000 DATE: Issue Date

DRAWN BY: DTI CHECKED BY: JAV

OWNER: CITY OF WILLMAR

Revision	Date

ROBBINS ISLAND  
 AMPHITHEATER

WILLMAR, MN

SITE IMPROVEMENTS  
 140092C601 - Plan Only

C114

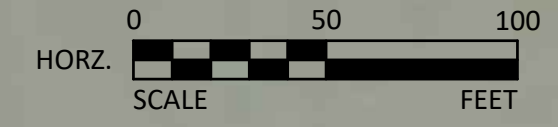

**ENGAN ASSOCIATES**  
ARCHITECTS | INTERIOR DESIGNERS  
shared vision. innovative design.  
311 4th Street SW, P.O. Box 956, Willmar, MN 56201  
320-235-0860 FAX: 320-235-0861 | www.engan.com



Certification & Seal:

**PRELIMINARY**

**NOT FOR CONSTRUCTION**

OWNER'S NAME: \_\_\_\_\_ DATE: MM/DD/YYYY

LIC. NO. XXXXX DATE MM/DD/YYYY

PROJECT # 00-000 DATE: Issue Date

DRAWN BY: DTI CHECKED BY: JAV

OWNER: CITY OF WILLMAR

Revision	Date

ROBBINS ISLAND  
AMPHITHEATER

WILLMAR, MN

TRAFFIC CONTROL  
140092C701 - Plan Only

C115

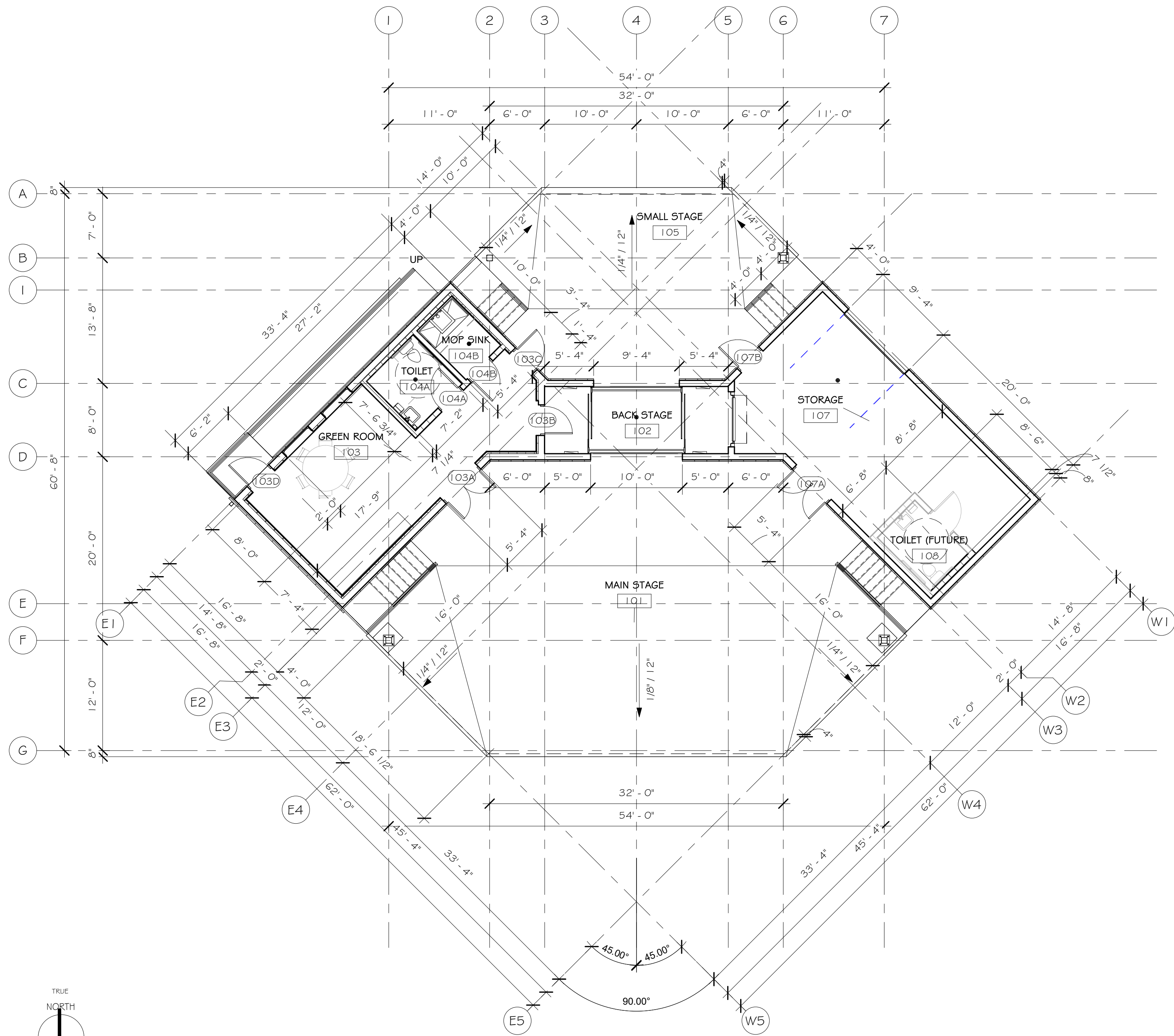

**STAGE LEVEL**

SCALE: 1/8" = 1'-0"

ROOM FINISH SCHEDULE - MAIN LEVEL									
ROOM #	ROOM NAME	CEILING	WALLS				BASE	FLOOR	COMMENTS
			NORTH	EAST	SOUTH	WEST			
101	MAIN STAGE	4	1	1	-	1	2	6	
102	BACK STAGE	4	1	1	1	1	1	5	
103	GREEN ROOM	4	1	1	1	1	1	6	C
104A	TOILET	5	5	5	5	5	6	6	
104B	MOP SINK	5	5	5	5	5	1	6	A,D
105	SMALL STAGE	4	-	1	1	1	1	1	C
107	STORAGE	1	2	2	2	2	2	6	B
108	TOILET (FUTURE)	1	5	5	5	5	2	6	

**GENERAL NOTES**

- THE CONTRACTOR SHALL FAMILIARIZE HIMSELF WITH THE PROJECT AND VERIFY ALL CONDITION AND DIMENSIONS.
- THE CONTRACTOR SHALL VERIFY EXACT ELEVATIONS, INVERTS, AND LOCATIONS OF ALL UTILITIES. CONTRACTOR SHALL CONFORM TO ALL APPLICABLE CODES.
- CONTRACTOR SHALL USE CAUTION TO LIMIT DAMAGE TO ANY EXISTING PLANTINGS, PROPERTY AND ADJOINING SURFACES.
- CONTRACTOR SHALL IMMEDIATELY NOTIFY THE ARCHITECT IF ANY EXISTING CONDITIONS DIFFER FROM THE PLANS.
- THE GENERAL CONTRACTOR IS RESPONSIBLE TO VERIFY ALL DIMENSIONS. SOLID BLOCKING SHALL BE PROVIDED FOR ALL WALL HUNG EQUIPMENT, CABINETS, CURTAIN RODS, AND ACCESSORIES.
- CAULK AND MAKE WATERTIGHT ALL CONTROL AND EXPANSIONS JOINTS.
- ALL GYPSUM BOARD SHALL BE TYPE "X". RESTROOM GYPSUM BOARD SHALL BE CEMENT BACKING BOARD.
- INSTALL VAPOR BARRIER UNDER NEW CONCRETE FLOOR SLABS ON GRADE.
- NO CONCRETE CURING MATERIAL MAY BE USED WHICH VIOLATES FLOOR COVERING MANUFACTURER'S RECOMMENDATIONS.
- ALL JOINTS IN STONE SILLS TO STONE SILLS AND STONE TO BRICK SHALL BE CAULKED.
- ALL WOOD BLOCKING IN PARTITIONS AND ABOVE CEILING SHALL BE FIRE RETARDANT TREATED.
- ALL FOUNDATION WALLS TO HAVE MINIMUM OF 4'-0" OF GRANULAR BACKFILL COVERED WITH 1'-0" MINIMUM OF IMPERVIOUS BACKFILL.
- ALL CONCRETE SLABS AND SIDEWALKS TO HAVE MINIMUM OF 4" GRANULAR BASE.
- SLOPE ALL FLOORS NOTES TO SLOPE 1% - 2%.
- ALL PERIMETER FOUNDATION RIGID INSULATION TO BE ADHERED TO FOUNDATION WALL.
- ALL NEW TO HAVE INTERIOR WINDOW BLINDS BY WINDOW SUPPLIER.
- N.I.C. REFERS TO ITEMS THAT ARE NOT IN THIS CONTRACT.
- THE ON SITE SUPERINTENDENT SHALL OVERSEE BASIC LAYOUT AND COORDINATION FOR MECHANICAL, ELECTRICAL AND OTHER TRADES.
- PATCH WHERE MECHANICAL AND ELECTRICAL PENETRATE WALL.
- ALL GYP. BD. ON EXTERIOR WALLS TO BE MOISTURE RESISTANT.

**ROOM FINISH SCHEDULE**

- CEILING**
- ACOUSTICAL PANEL CEILING (LAY-IN) TYPE "A"
  - EXPOSED META DECK - CELLULAR ACCOUSTIC - PAINTED
  - PAINTED GYP BOARD
- WALL MATERIALS**
- BURNISHED CMU
  - GYPSUM BOARD
  - GYPSUM BOARD
  - FPR WAINSCOT WITH GYPSUM BOARD ABOVE
  - FRP FULL WALL
- FINISH**
- PAINTED EGGSHELL UNFINISHED
  - PAINTED EGGSHELL
- BASE**
- RESILIENT VINYL
  - CERAMIC TILE
- FLOORING**
- CERAMIC TILE?
  - EXPOSED CONCRETE - SEALED

**ROOM SCHEDULE REMARKS**

- INSTALL 4' HIGH FIBERGLASS REINFORCED WALL PANEL BY SECTION 06200.
- NO FINISHES EXCEPT TAPING GYP BD. ON ALL STUDS.
- PATCH WHERE MECHANICAL AND ELECTRICAL PENETRATE WALL.
- LOCATE MOP SINK DRAIN & BASIN TO ALLOW FUTURE SHOWER INSTALLATION.

**FINISH NOTES**

- THE STAIR TREADS SHALL HAVE A GRIT SURFACE APPLIED.
- CERAMIC WALL TILE ON WALLS NOTED AS GYPSUM BOARD SHALL BE MOUNTED ON CEMENTITIOUS BACKER UNITS BY SECTIONS 09255. THIS IS MOUNTED OVER THE GYPSUM BOARD CALLED FOR IN THE PARTITION TYPES. WHEN INSTALLATION CALLS FOR A WAINSCOT, INSTALL AN ADDITIONAL LAYER OF 1/2" GYPSUM BOARD ABOVE BACKER UNITS TO MAKE WALL FLUSH.
- APPLY A SKIM COAT TO GYPSUM BOARD AT WALLS TO BE PAINTED.
- PAINT ALL GYPSUM BOARD IN FINISHED AREAS THAT IS NOT CALLED TO BE COVERED WITH OTHER MATERIAL.
- PAINT ALL EXPOSED UNFINISHED FERROUS METAL, INCLUDING ALL STEEL DOORS AND FRAMES AND OVERHEAD DOORS. THIS INCLUDES BUT IS NOT LIMITED TO: LINTELS, UNDER CABINET SUPPORTS, EXPOSED CONDUIT, AND EXPOSED DUCTWORK. PAINT THE EXISTING STEEL IN THE AREA OF RENOVATION.
- ALL EXPOSED CONCRETE FLOORS SHALL RECEIVE CHEMICAL HARDENERS AND SEALER.
- PAINT ALL RELOCATED PIPING AND EXPOSED CONDUITS. PAINT ALL PATCHED HOLES FROM MECHANICAL AND ELECTRICAL WORK TO MATCH EXISTING.
- PAINT MISC. ITEMS ON ROOF, INCLUDING BUT NOT LIMITED TO, ROOF JACKS, PLUMBING VENTS.
- ALL EXTERIOR WOOD SHALL BE STAINED.
- EXPOSED WOODWORK, WITH THE EXCEPTION OF DOORS AND MISCELLANEOUS TRIM, SHALL HAVE FINISH OF CLASS II FLAME-SPREAD RATING.
- (A) INDICATES LOCATION TO RECEIVE CLEAR OUTSIDE CORNER GUARD - SEE SPEC SECTION 06402

**DOOR AND FRAME SCHEDULE - MAIN LEVEL**

NUMBER	PANEL		FRAME			FIRE RATING	HARDWARE SET	COMMENTS
	WIDTH	HEIGHT	THICKNESS	MATERIAL	TYPE			
103A	2'-6"	7'-0"	1 3/4"	HM	F	HM	I	
103B	3'-0"	7'-0"	1 3/4"	HM	F	HM	I	
103C	3'-0"	7'-0"	1 3/4"	HM	F	HM	I	
103D	3'-0"	7'-0"	1 3/4"	HM	F	HM	I	
104A	3'-0"	7'-0"	1 3/4"	HM	F	HM	I	
104B	3'-0"	7'-0"	1 3/4"	HM	F	HM	I	
104H								
105D								
107A	2'-6"	7'-0"	1 3/4"	HM	F	HM	I	45
107B	3'-0"	7'-0"	1 3/4"	HM	F	HM	I	
108								
108	3'-0"	7'-0"	1 3/4"	HM	F	HM	I	

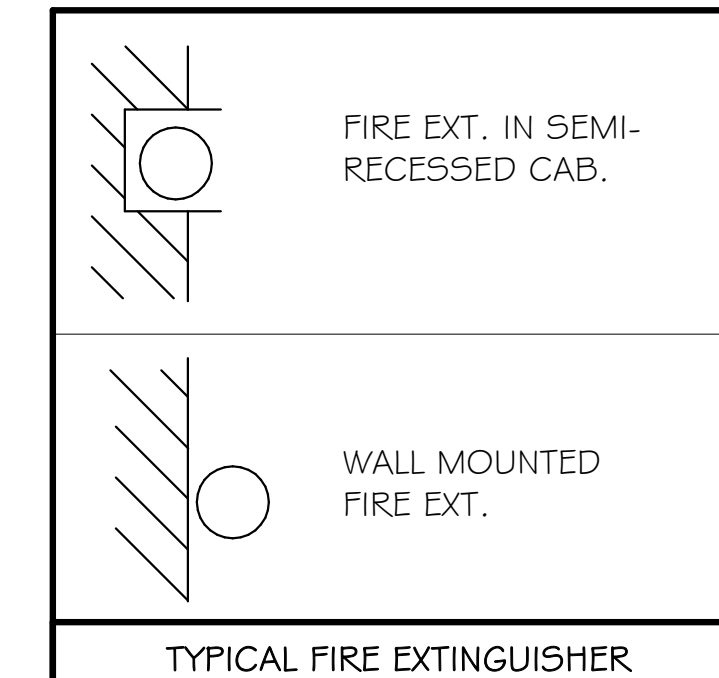
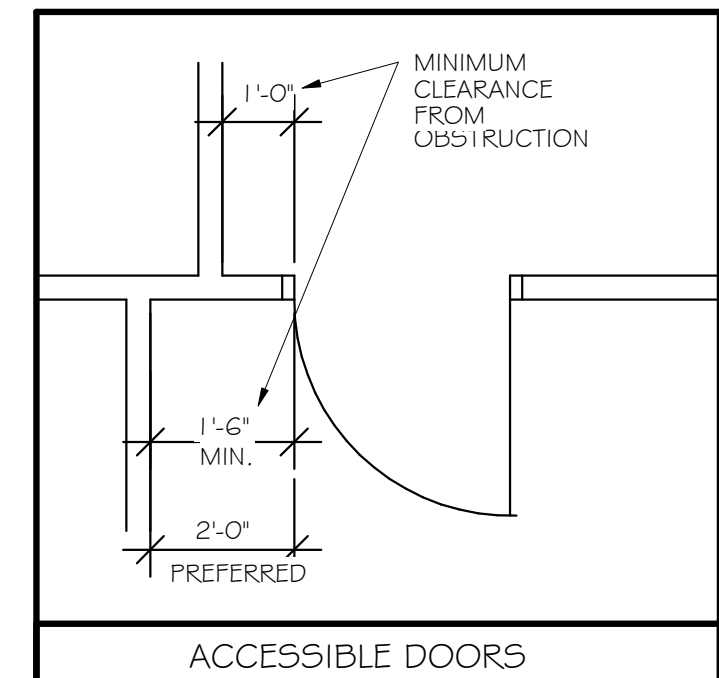

**ENGAN ASSOCIATES**  
 ARCHITECTS | INTERIOR DESIGNERS  
 shared vision. innovative design.  
 311 4th Street SW, P.O. Box 956, Willmar, MN 56201  
 320-235-0860 FAX: 320-235-0861 | www.engan.com



Certification & Seal:  
**PRELIMINARY**  
**NOT FOR CONSTRUCTION**

PROJECT #	XXX.XX	DATE:	-
DRAWN BY:	???	CHECKED BY:	???
OWNER: CLIENT NAME			
Revision		Date	

ROBBINS ISLAND  
 AMPHITHEATER

WILLMAR, MN  
 STAGE LEVEL

**A-131**

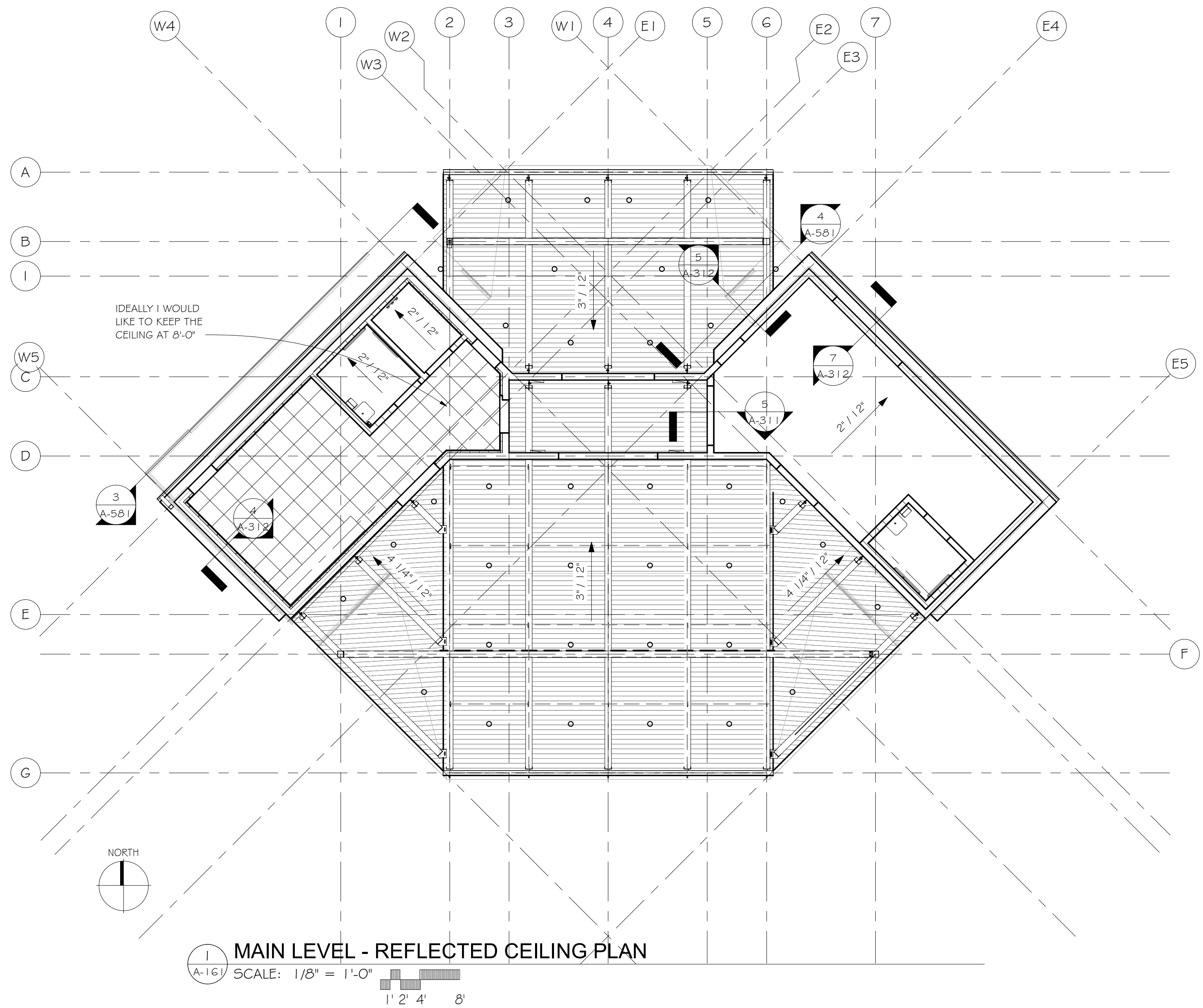

**ENGAN ASSOCIATES**  
 ARCHITECTS | INTERIOR DESIGNERS  
 shared vision. innovative design.  
 311 4th Street SW, P.O. Box 956, Willmar, MN 56201  
 320-235-0860 FAX: 320-235-0861 | www.engan.com



Certification # Seal:

**PRELIMINARY**  
**NOT FOR CONSTRUCTION**

PROJECT # XXX.XX DATE: --  
 DRAWN BY: ??? CHECKED BY: ???  
 OWNER: CLIENT NAME

Revision	Date

ROBBINS ISLAND  
 AMPHITHEATER

WILLMAR, MN

REFLECTED CEILING PLANS -  
 MAIN AND UPPER

A-161



3 **SOUTHWEST ELEVATION**

A-200 SCALE: 1/8" = 1'-0"  
1' 2' 4' 8'



1 **SOUTH ELEVATION NEW**

A-200 SCALE: 1/8" = 1'-0"  
1' 2' 4' 8'



2 **SOUTHEAST ELEVATION**

A-200 SCALE: 1/8" = 1'-0"  
1' 2' 4' 8'



4 **EAST ELEVATION**

A-200 SCALE: 1/8" = 1'-0"  
1' 2' 4' 8'

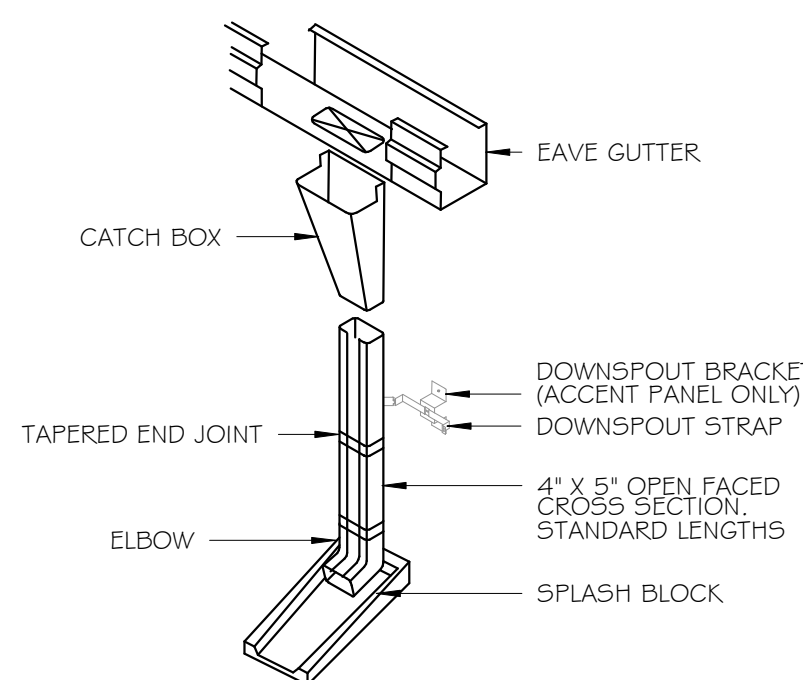

5 **DOWNSPOUT DETAIL 1**

A-200 SCALE: N.T.S.

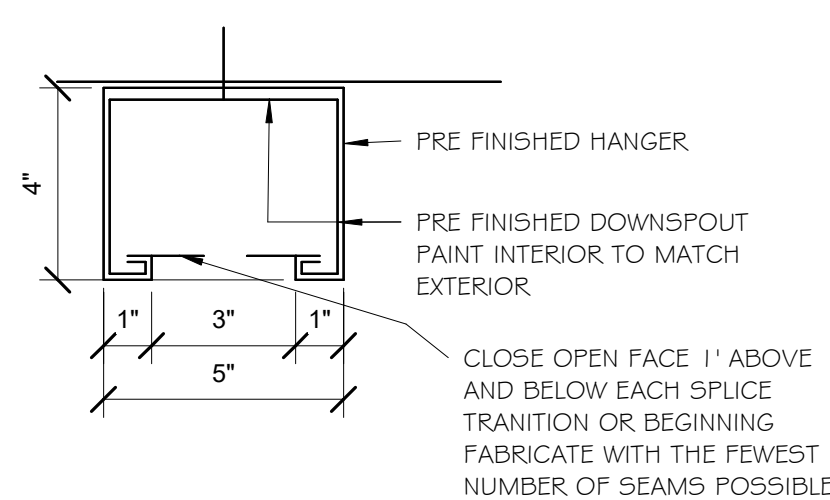

6 **DOWNSPOUT DETAIL 3**

A-200 SCALE: 3" = 1'-0"  
1/2' 1' 2' 4'

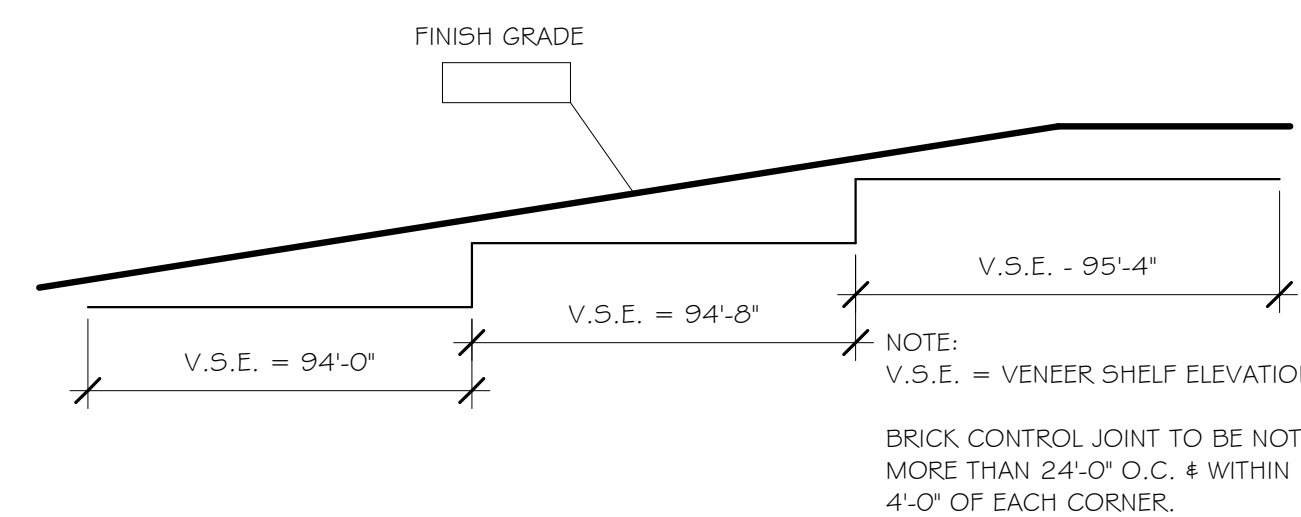

7 **VENEER SHELF ELEVATION DETAIL**

A-200 SCALE: 1/2" = 1'-0"  
3' 6' 1' 2'

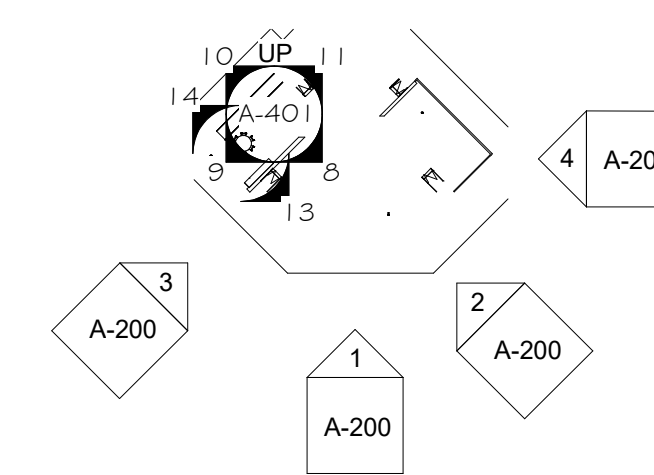

KEY PLAN - EXTERIOR ELEVATION



**ENGAN ASSOCIATES**  
ARCHITECTS | INTERIOR DESIGNERS  
shared vision. innovative design.  
311 4th Street SW, P.O. Box 956, Willmar, MN 56201  
320-235-0860 FAX: 320-235-0861 | www.engan.com



Certification # Seal:  
**PRELIMINARY**  
**NOT FOR CONSTRUCTION**

PROJECT # XXX.XX DATE: -  
DRAWN BY: ??? CHECKED BY: ???  
OWNER: CLIENT NAME

Revision	Date

ROBBINS ISLAND  
AMPHITHEATER

WILLMAR, MN

EXTERIOR ELEVATIONS

A-200



1  
A-201  
NORTHEAST ELEVATION  
SCALE: 1/8" = 1'-0"  
1' 2' 4' 8'



2  
A-201  
NORTH ELEVATION  
SCALE: 1/8" = 1'-0"  
1' 2' 4' 8'

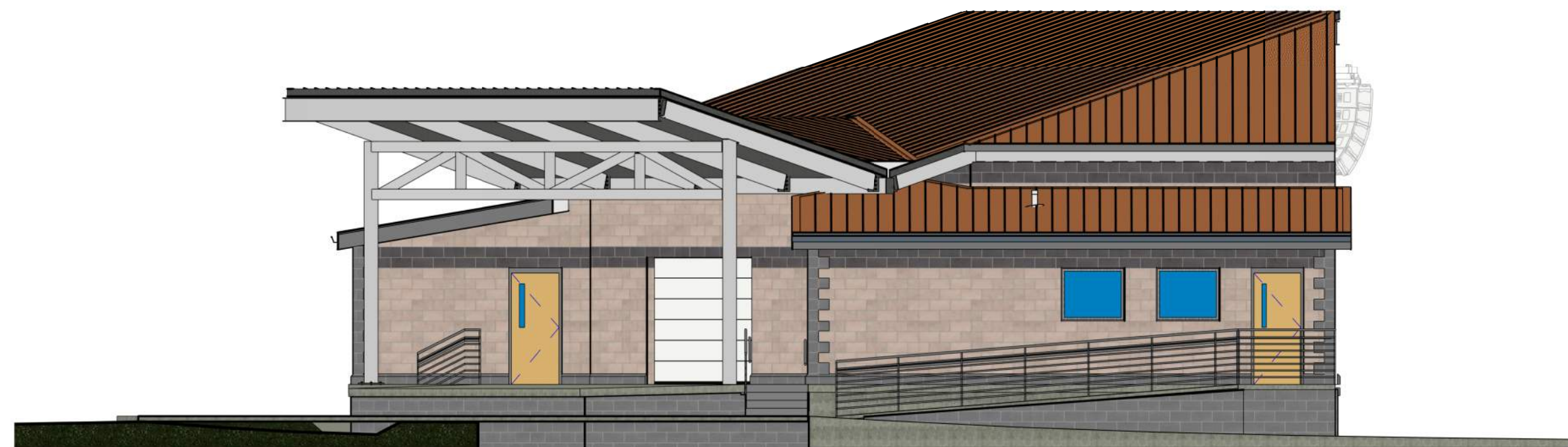

3  
A-201  
NORTHWEST ELEVATIONS  
SCALE: 1/8" = 1'-0"  
1' 2' 4' 8'



4  
A-201  
WEST ELEVATION  
SCALE: 1/8" = 1'-0"  
1' 2' 4' 8'

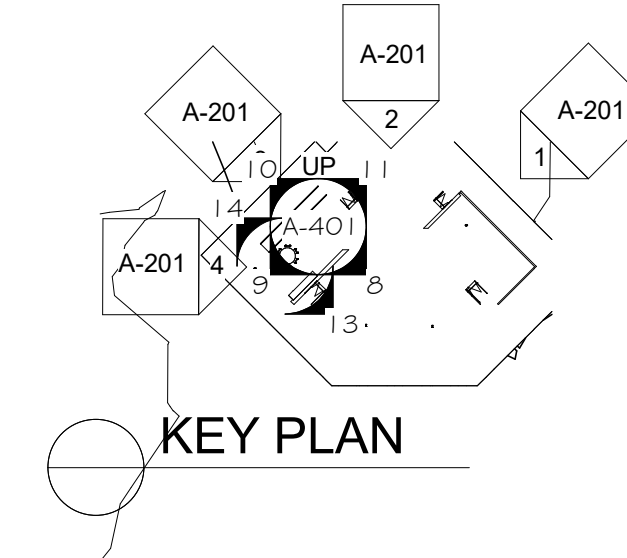

**ENGAN ASSOCIATES**  
ARCHITECTS | INTERIOR DESIGNERS  
shared vision. innovative design.  
311 4th Street SW, P.O. Box 956, Willmar, MN 56201  
320-235-0860 FAX: 320-235-0861 | www.engan.com



Certification # Seal:  
**PRELIMINARY**  
**NOT FOR CONSTRUCTION**

PROJECT # XXX.XX DATE: \_\_\_\_\_  
DRAWN BY: \_\_\_\_\_ CHECKED BY: \_\_\_\_\_  
OWNER: CLIENT NAME

Revision	Date

ROBBINS ISLAND  
AMPHITHEATER

WILLMAR, MN

EXTERIOR ELEVATIONS

A-201



1 MAIN STAGE RIGHT  
A-202 SCALE: N.T.S.

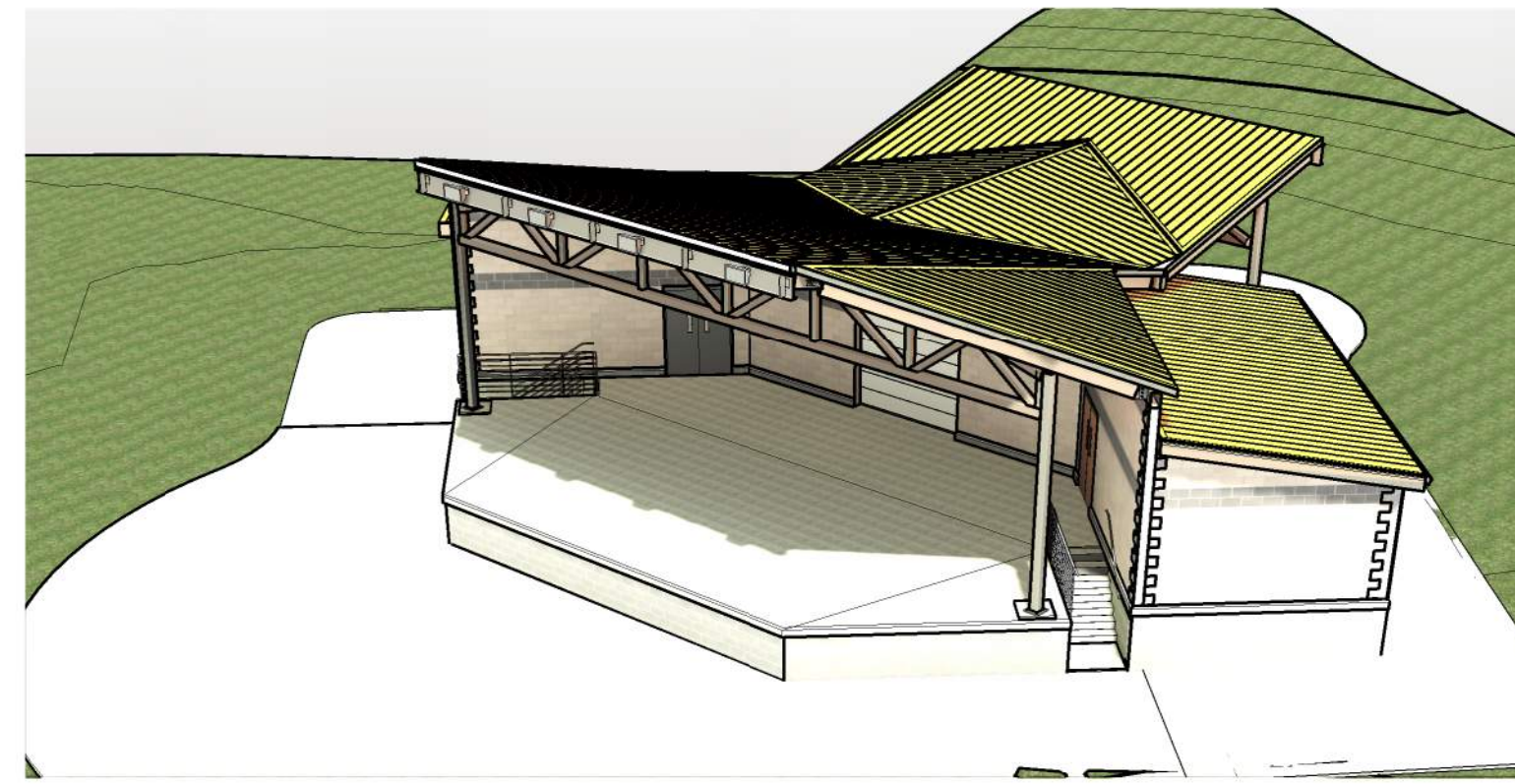

5 MAIN STAGE RIGHT - BIRDS EYE VIEW  
A-202 SCALE: N.T.S.

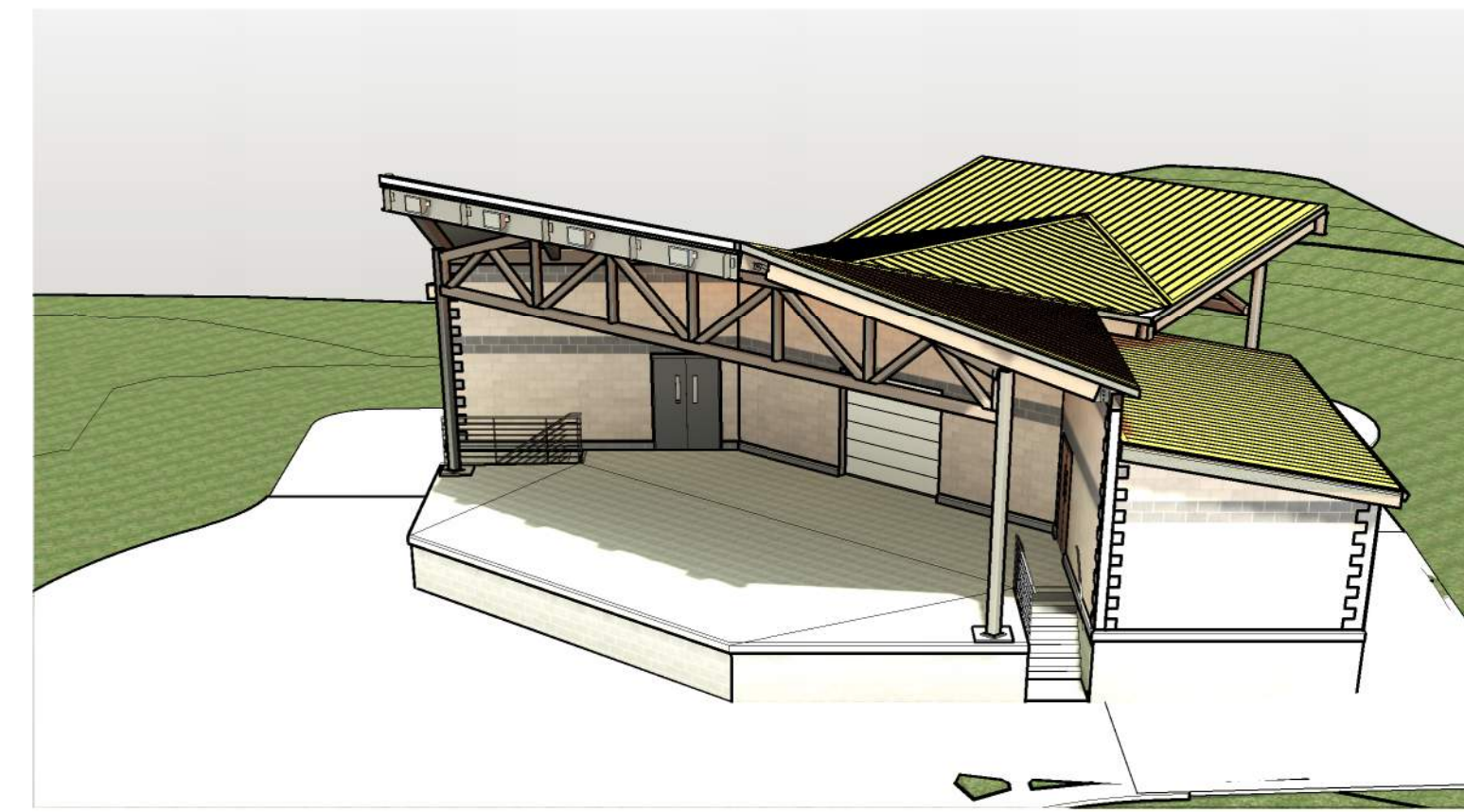

7 COLORED MAIN STAGE RIGHT - BIRDS EYE VIEW  
A-202 SCALE: N.T.S.

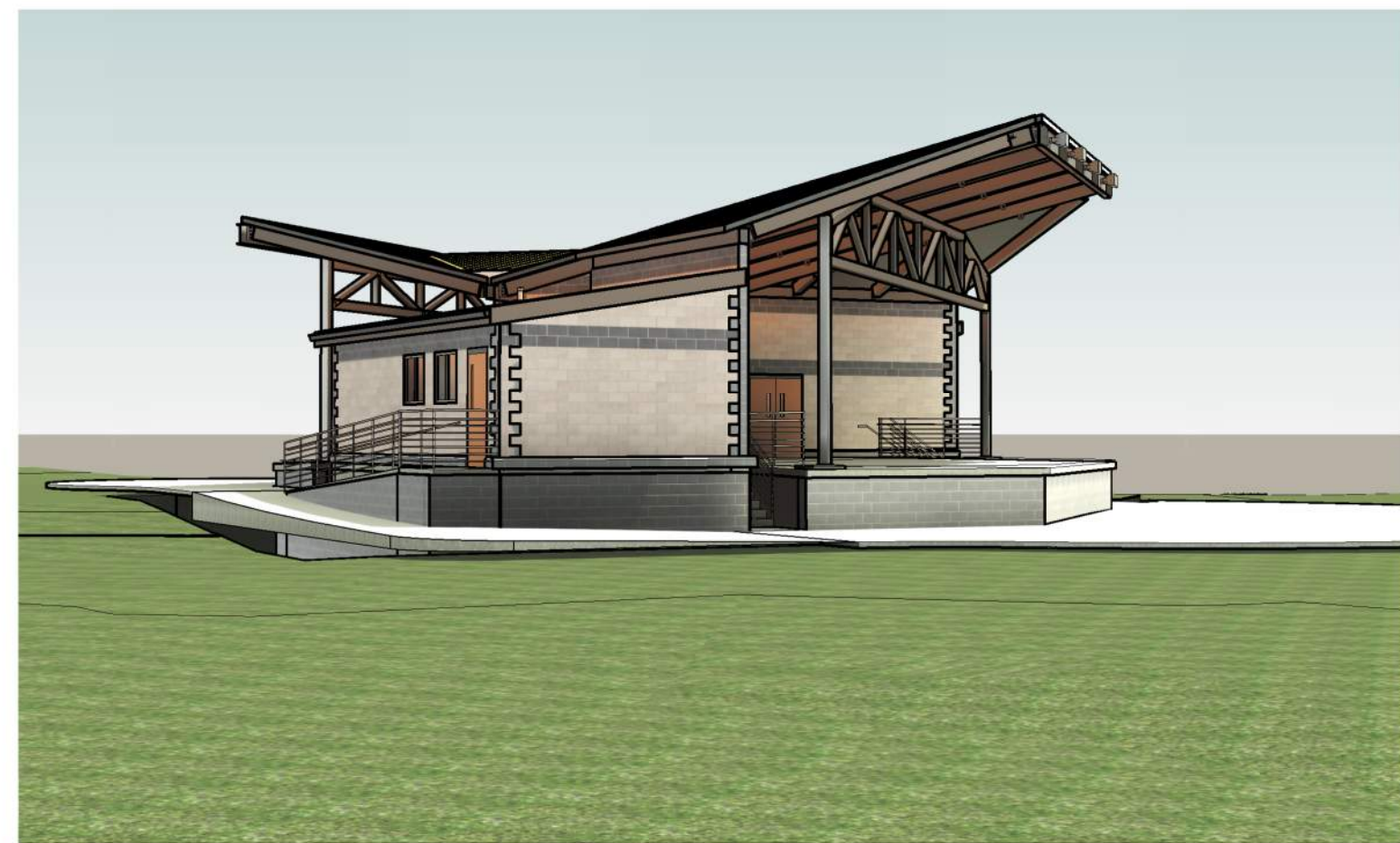

2 MAIN STAGE LEFT  
A-202 SCALE: N.T.S.

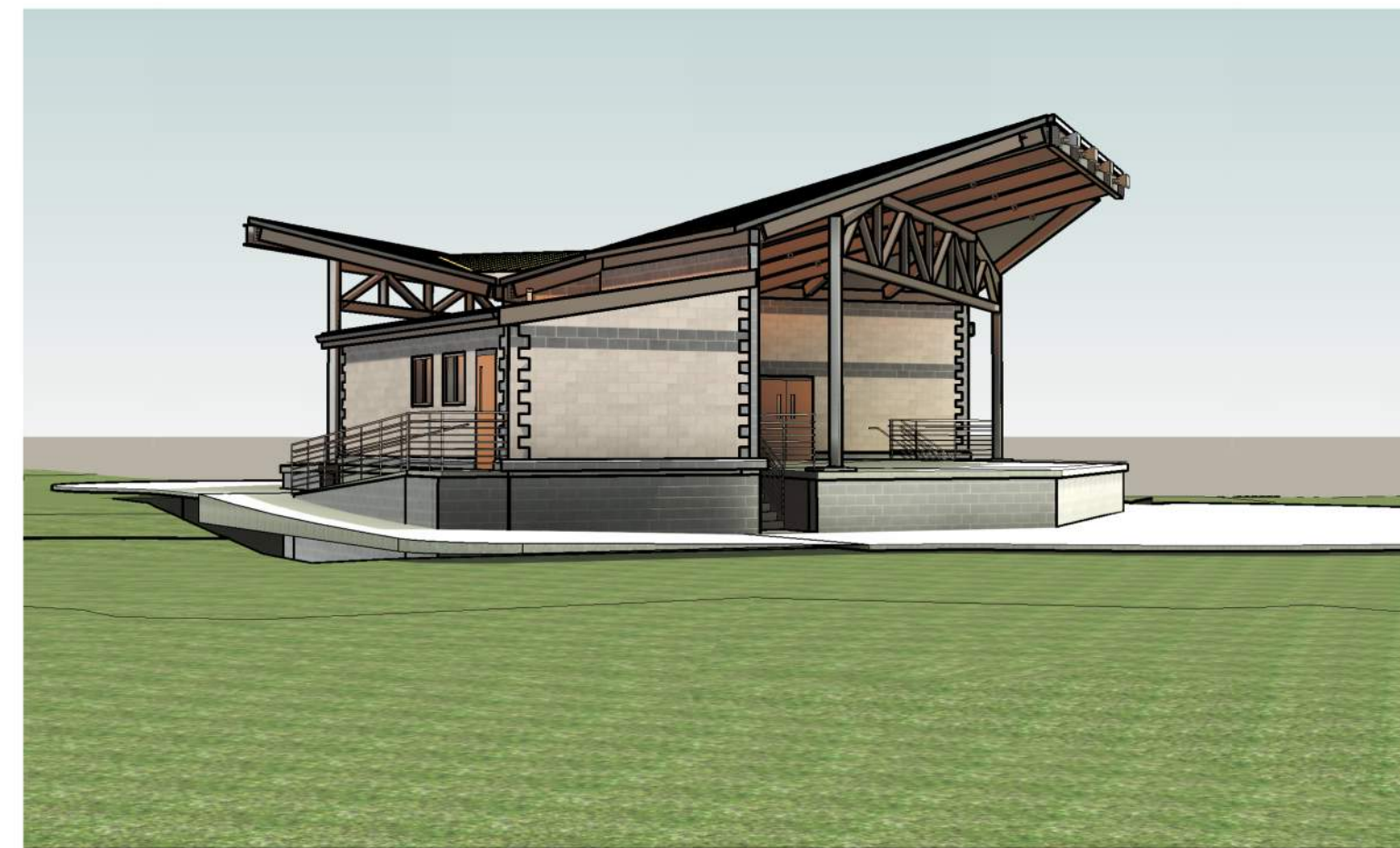

4 MAIN STAGE LEFT - BIRDS EYE VIEW  
A-202 SCALE: N.T.S.

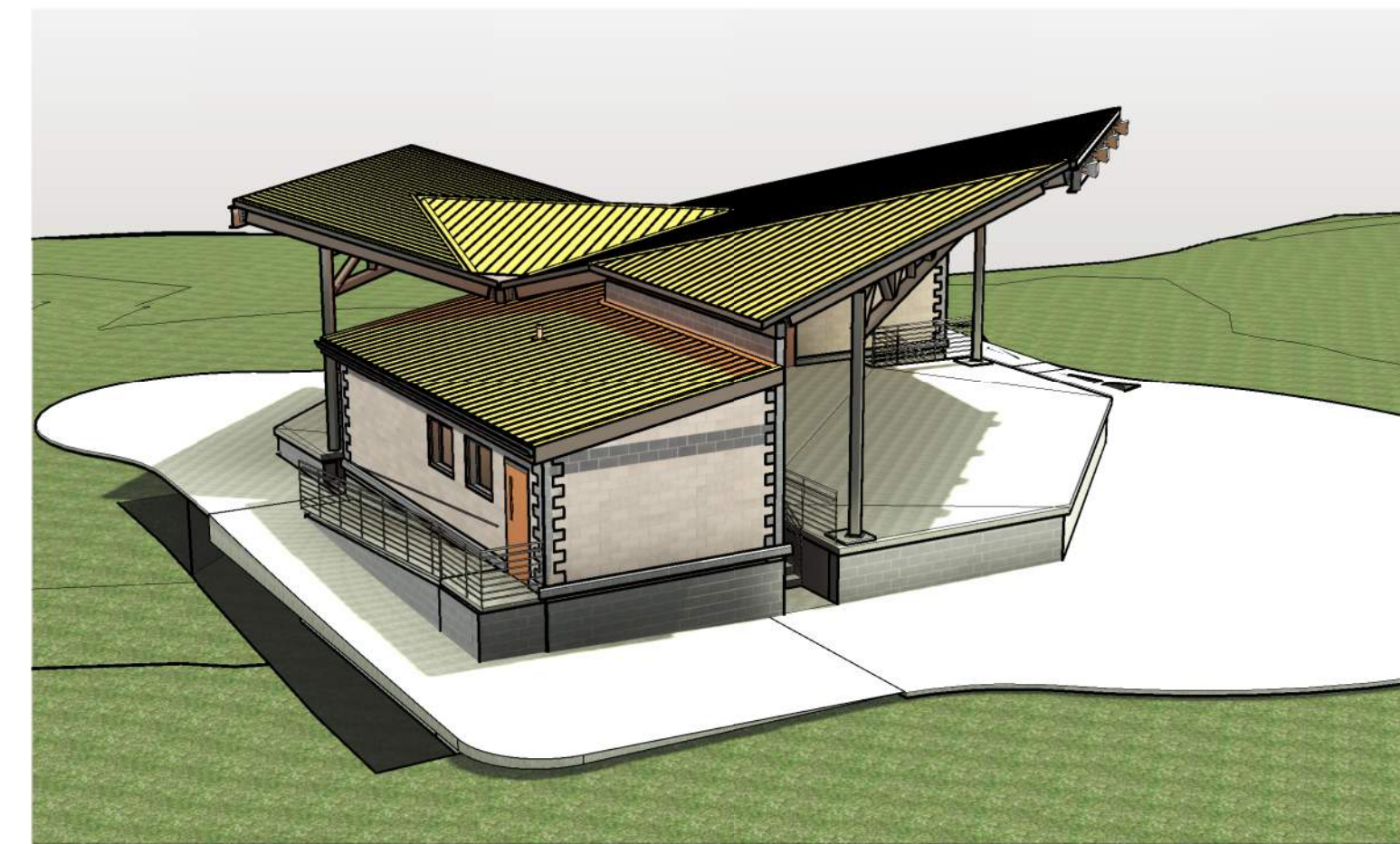

8 COLORED MAIN STAGE LEFT - BIRDS EYE VIEW  
A-202 SCALE: N.T.S.



3 SMALL STAGE  
A-202 SCALE: N.T.S.

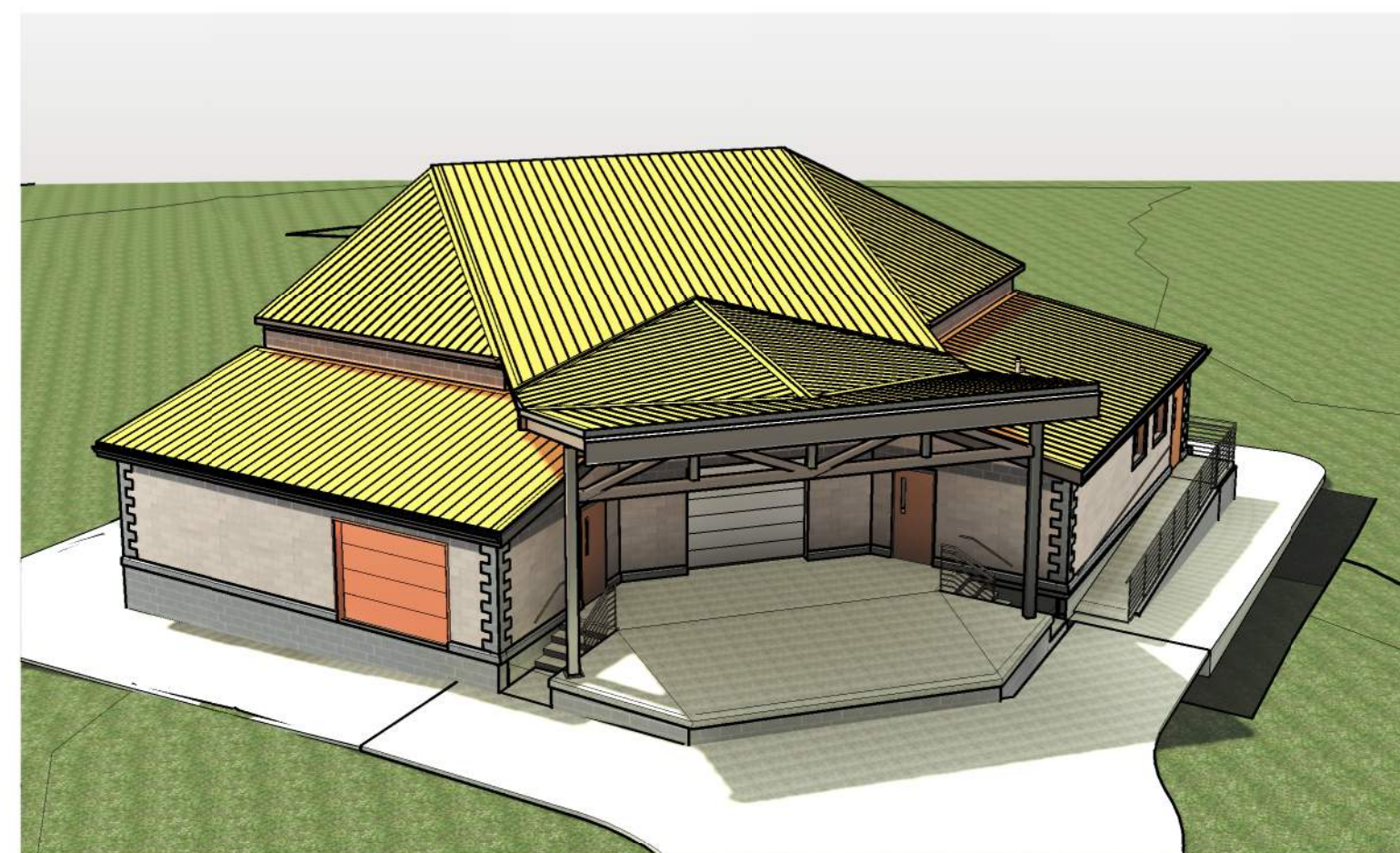

6 SMALL STAGE - BIRDS EYE VIEW  
A-202 SCALE: N.T.S.

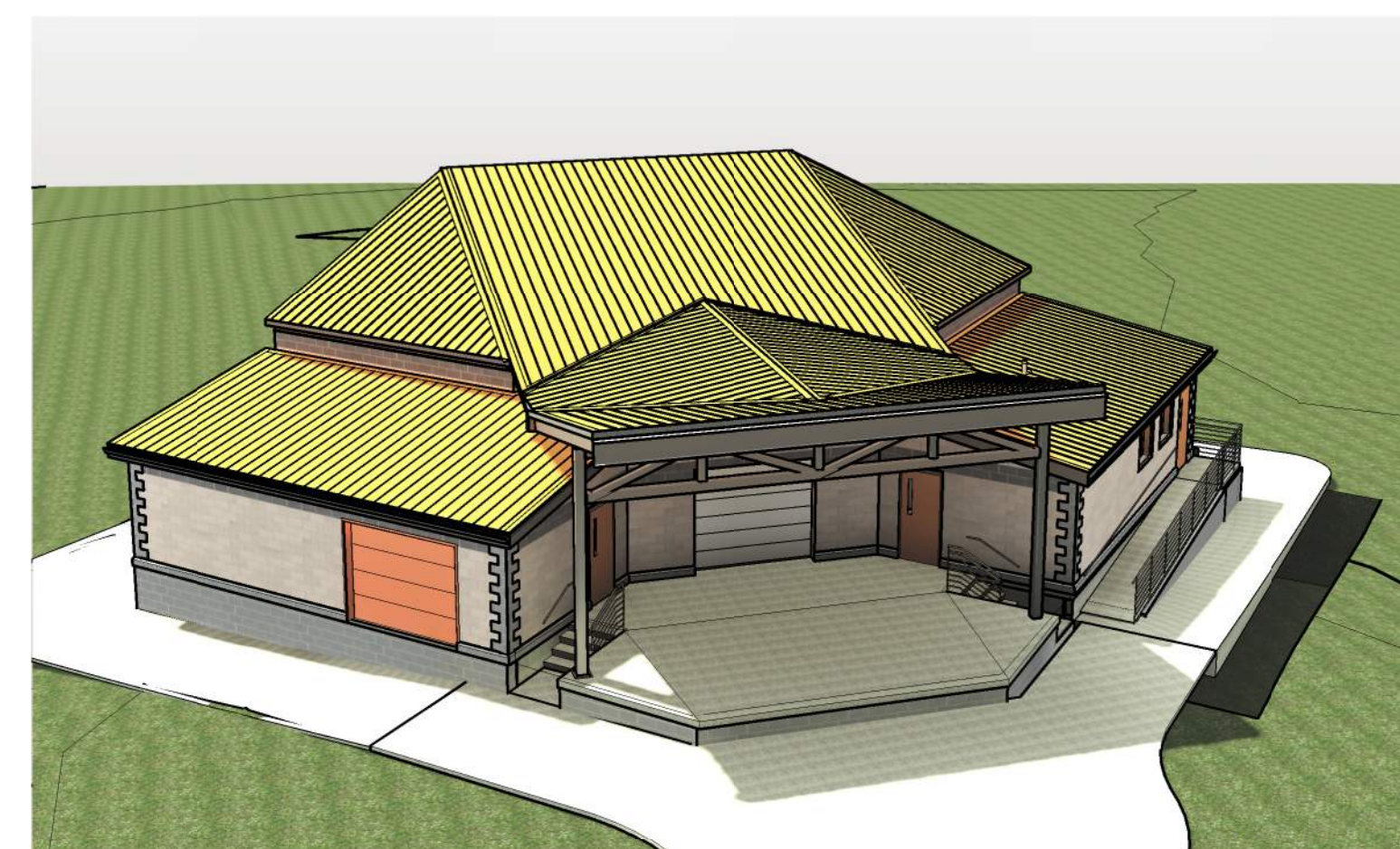

9 COLORED SMALL STAGE - BIRDS EYE VIEW  
A-202 SCALE: N.T.S.



**ENGAN ASSOCIATES**  
ARCHITECTS | INTERIOR DESIGNERS  
shared vision. innovative design.  
311 4th Street SW, P.O. Box 956, Willmar, MN 56201  
320-235-0860 FAX: 320-235-0861 | www.engan.com



Real People. Real Solutions.



Certification # Seal:

**PRELIMINARY**  
**NOT FOR CONSTRUCTION**

PROJECT # XXX.XX DATE: \_\_\_\_\_

DRAWN BY: \_\_\_\_\_ CHECKED BY: \_\_\_\_\_

OWNER: CLIENT NAME

Revision	Date

ROBBINS ISLAND  
AMPHITHEATER

WILLMAR, MN

EXTERIOR PERSPECTIVES

A-202



**ENGAN ASSOCIATES**  
 ARCHITECTS | INTERIOR DESIGNERS  
 shared vision. innovative design.  
 311 4th Street SW, P.O. Box 956, Willmar, MN 56201  
 320-235-0860 FAX: 320-235-0861 | www.engan.com



Certification # Seal:

**PRELIMINARY**  
**NOT FOR CONSTRUCTION**

PROJECT # XXX.XX DATE: \_\_\_\_\_  
 DRAWN BY: \_\_\_\_\_ CHECKED BY: \_\_\_\_\_  
 OWNER: CLIENT NAME

Revision	Date

ROBBINS ISLAND  
 AMPHITHEATER

WILLMAR, MN  
 EXTERIOR RENDERINGS

A-203

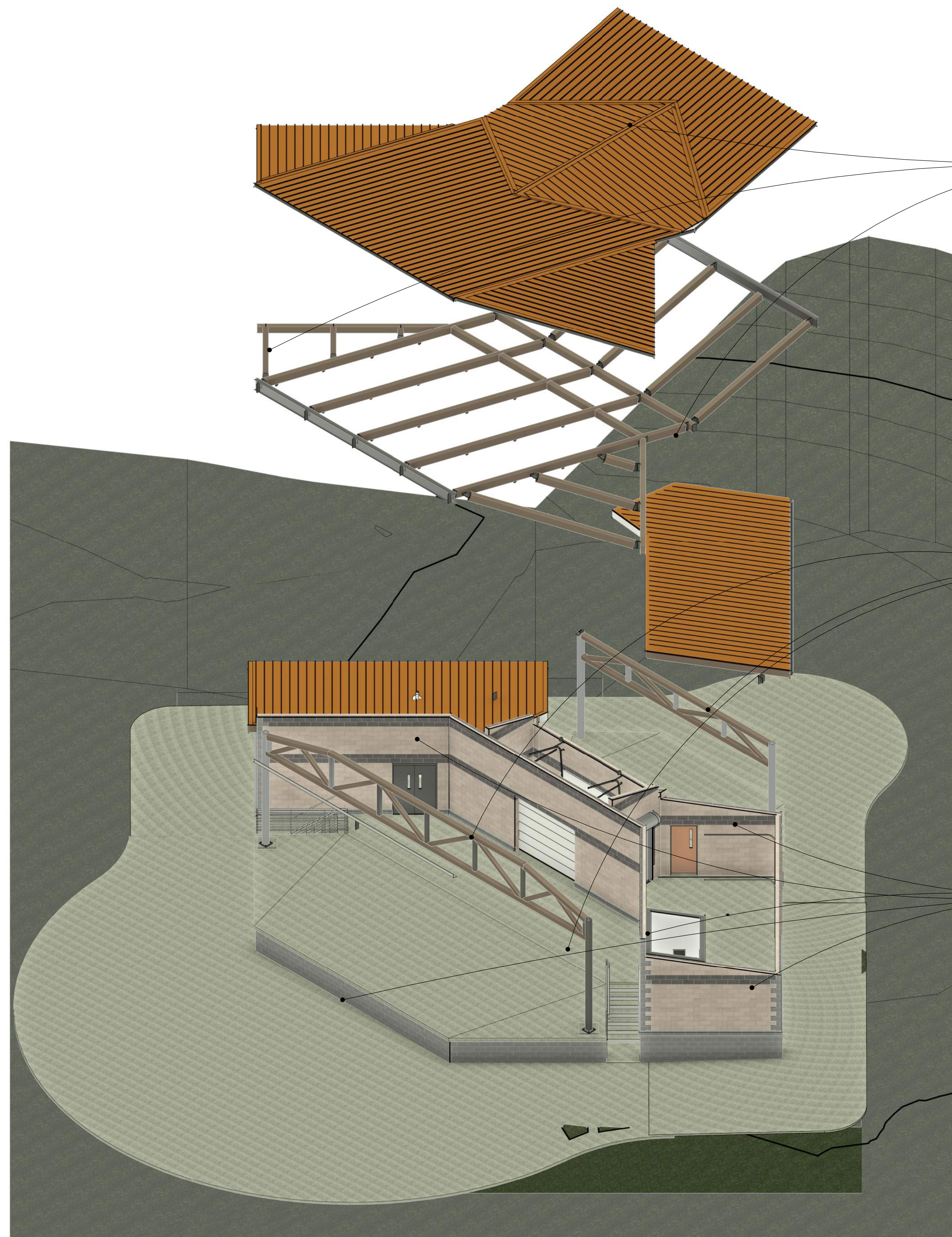

ROOFING & STRUCTURAL STEEL

BLACK TUBE STEEL -  
COLUMNS & FRAMING

BASE & EXTERIOR  
WALL OPTIONS

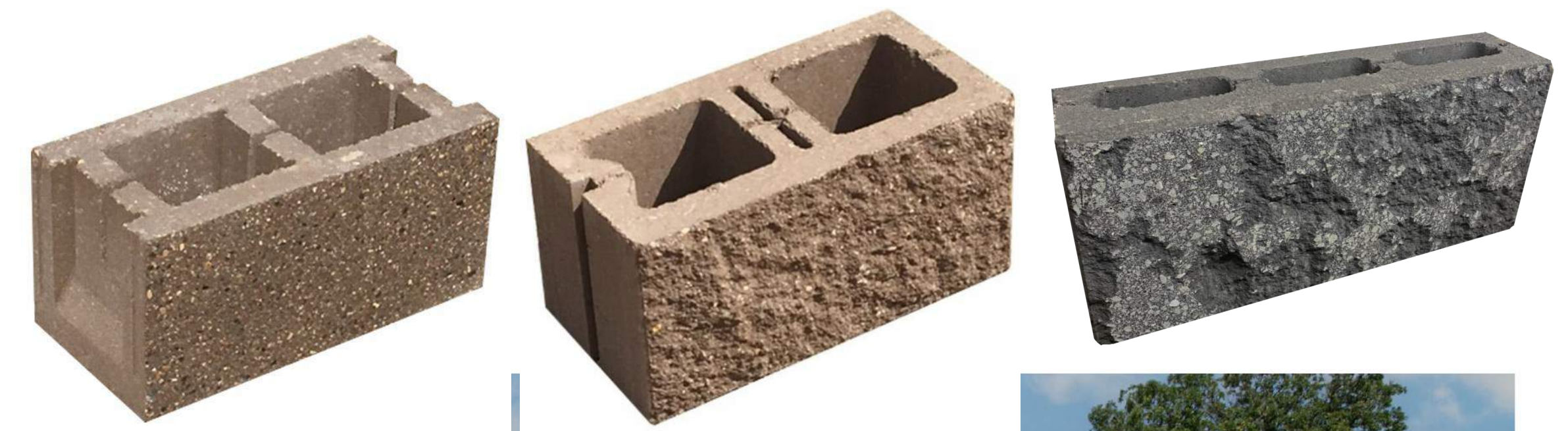
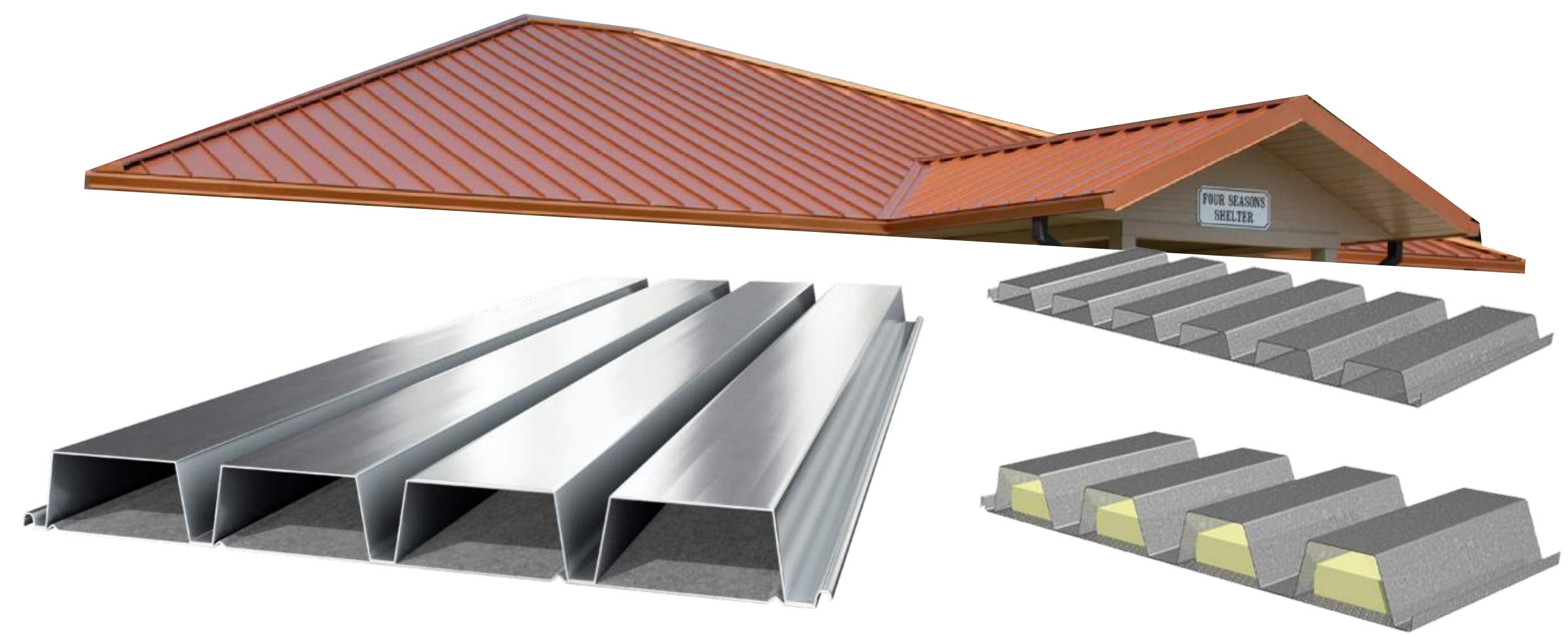

**ENGAN ASSOCIATES**  
ARCHITECTS | INTERIOR DESIGNERS  
shared vision. innovative design.  
311 4th Street SW, P.O. Box 956, Willmar, MN 56201  
320-235-0860 FAX: 320-235-0861 | www.engan.com



Certification & Seal:  
**PRELIMINARY**  
**NOT FOR CONSTRUCTION**

PROJECT #	XXX.XX	DATE:	
DRAWN BY:		CHECKED BY:	
OWNER: CLIENT NAME			
Revision		Date	

ROBBINS ISLAND  
AMPHITHEATER

WILLMAR, MN

MATERIAL PALLET

A-204

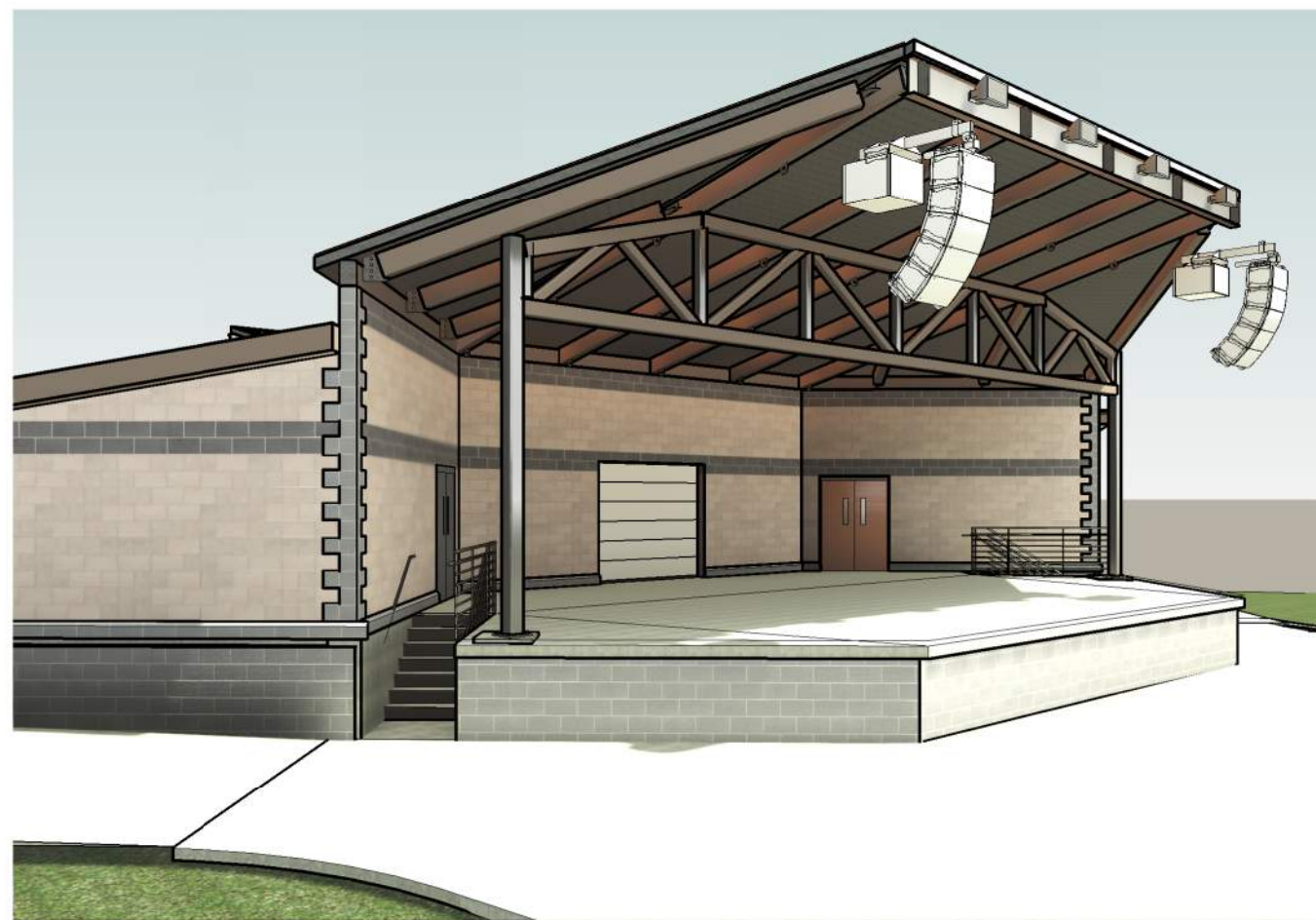

3 3D View 12  
A-209 SCALE: N.T.S.

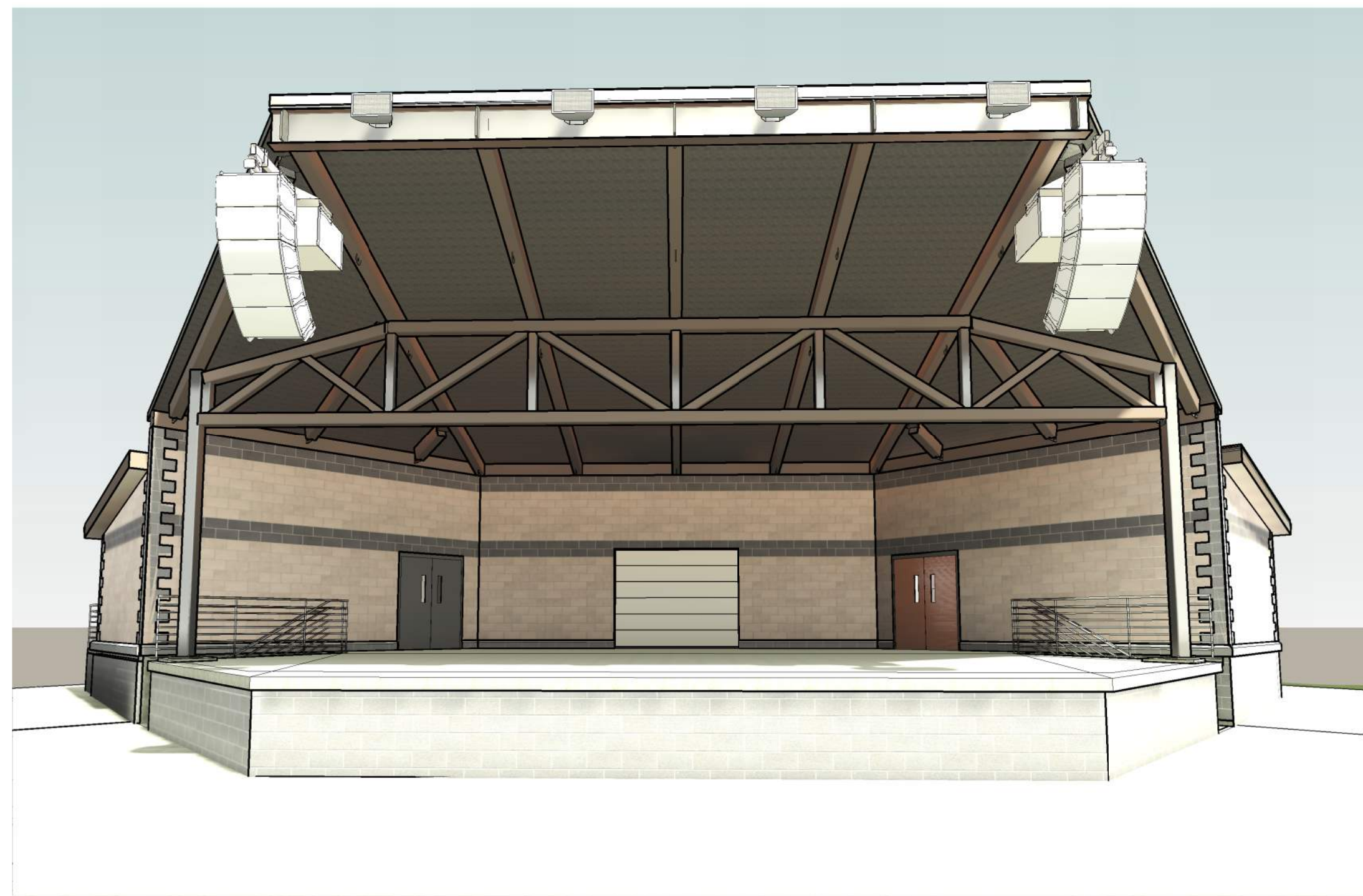

2 3D View 11  
A-209 SCALE: N.T.S.

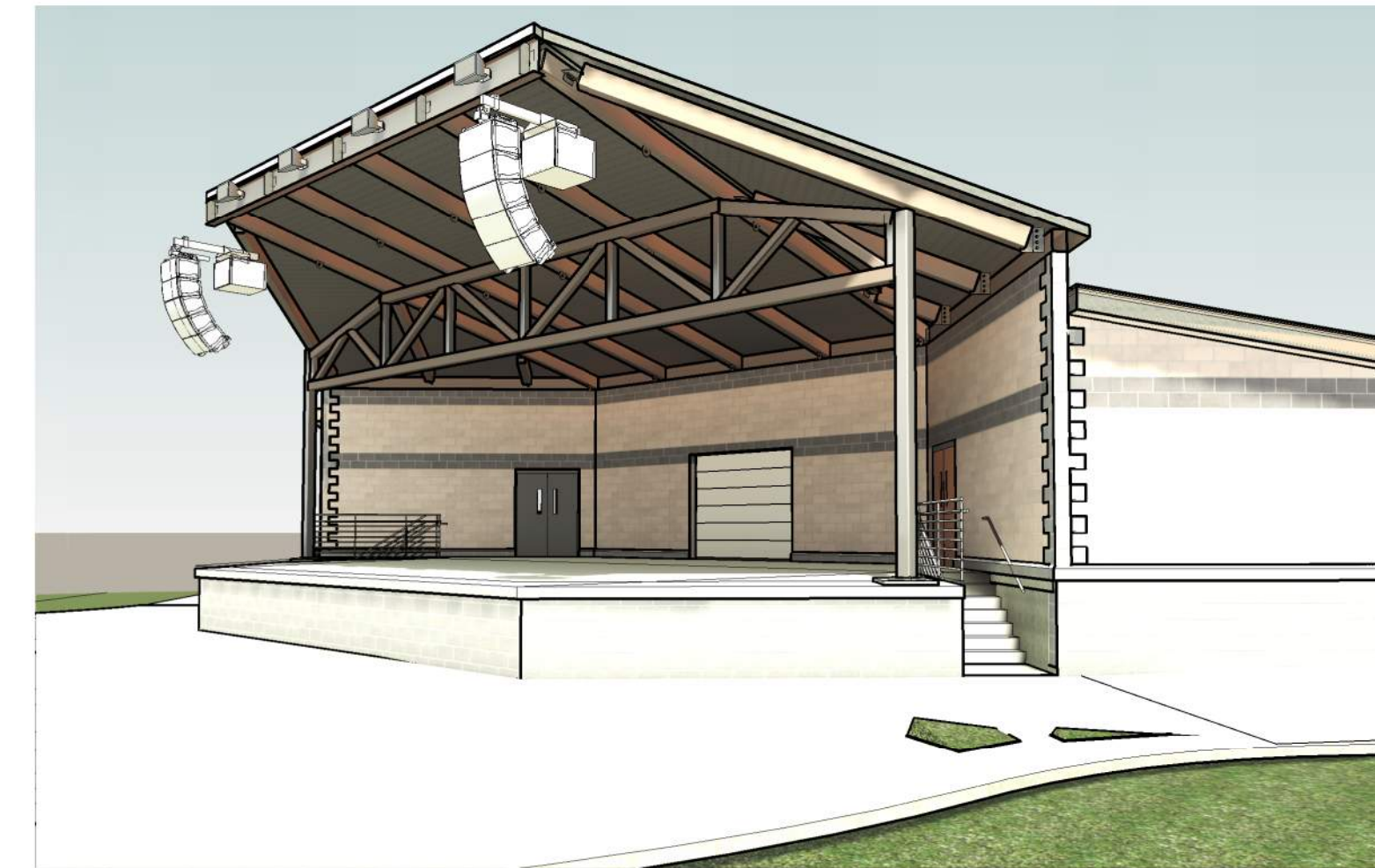

1 3D View 10  
A-209 SCALE: N.T.S.

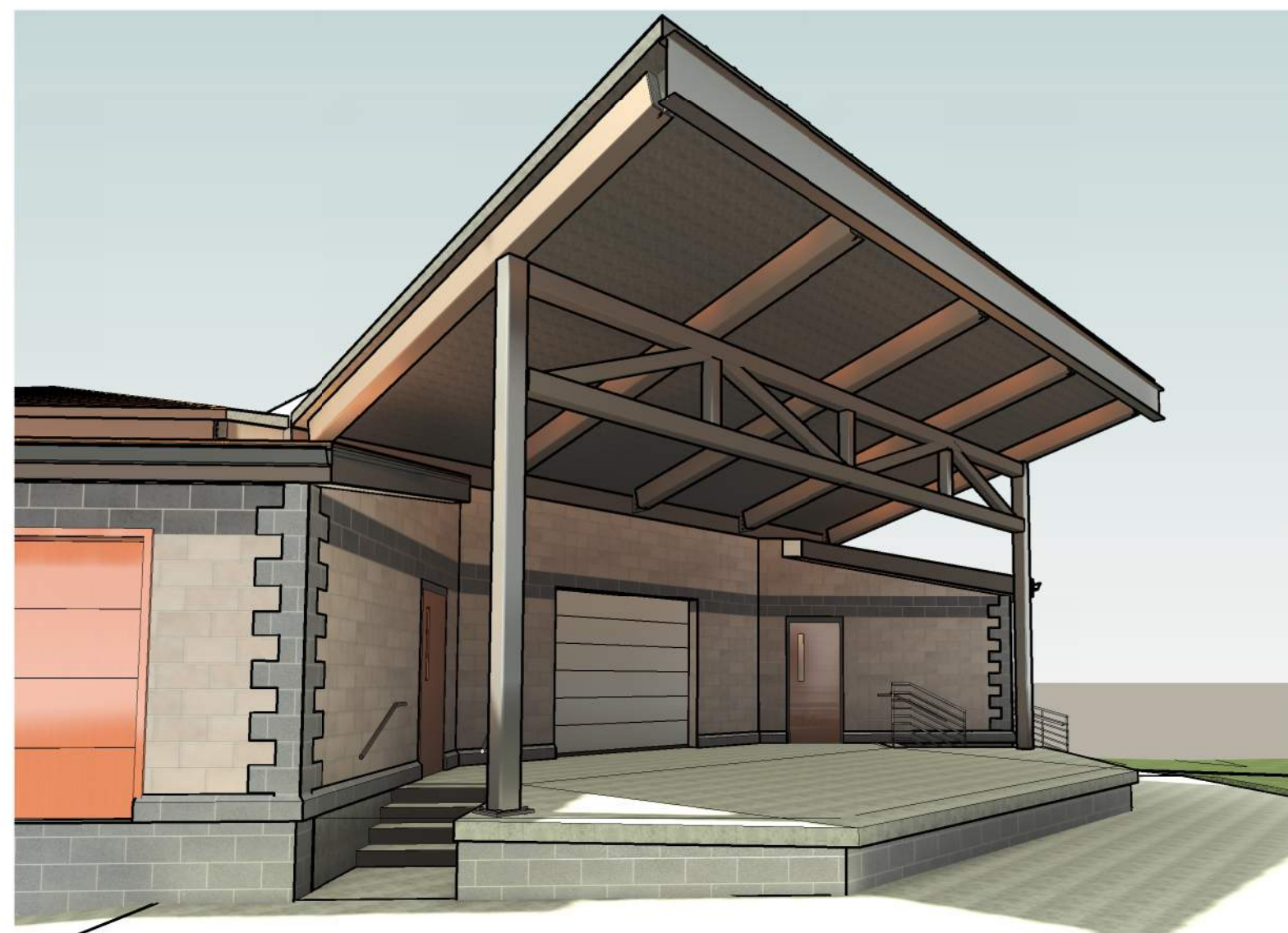

6 3D View 20  
A-209 SCALE: N.T.S.



4 3D View 18  
A-209 SCALE: N.T.S.

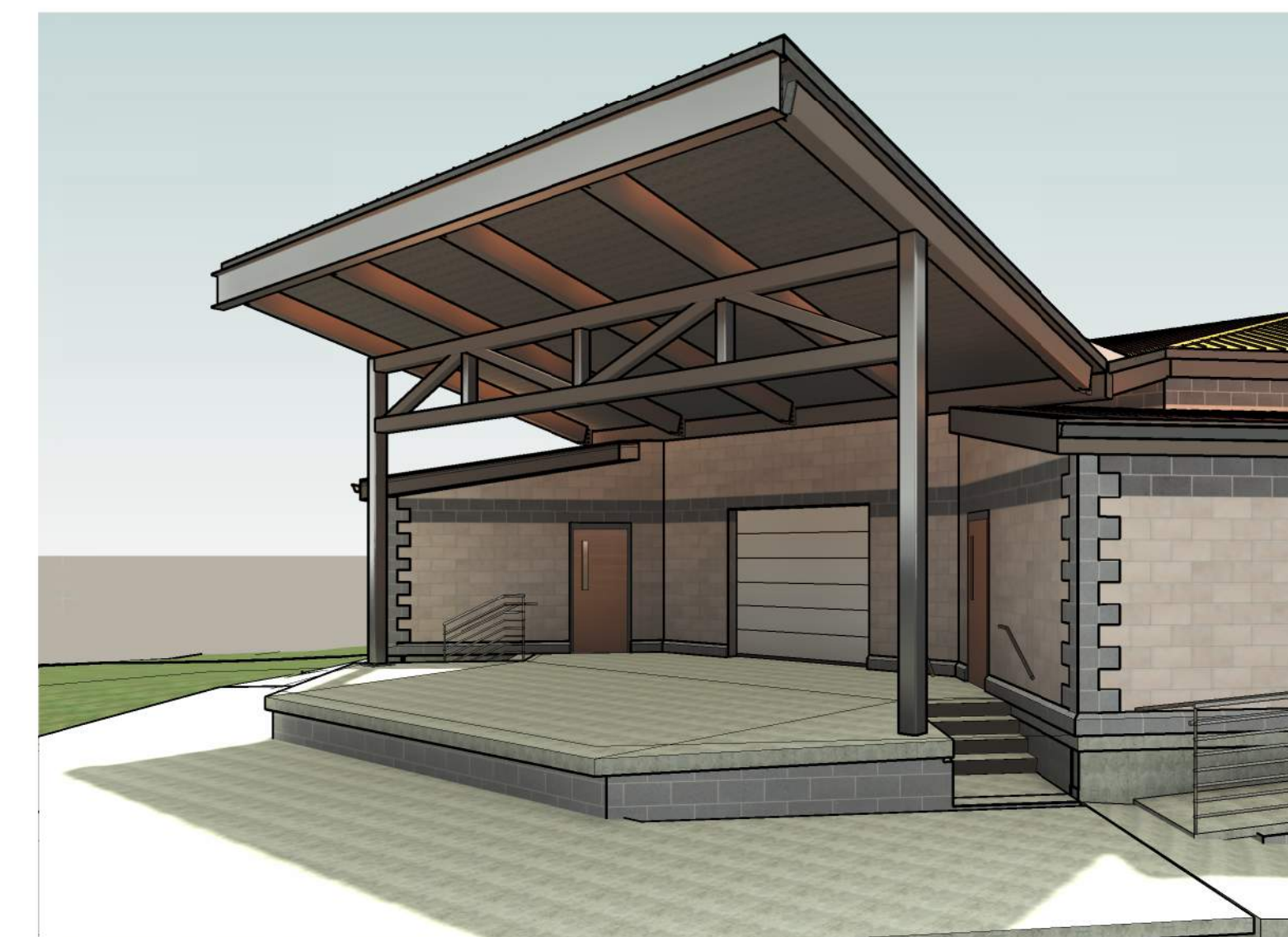

5 3D View 19  
A-209 SCALE: N.T.S.



**ENGAN ASSOCIATES**  
ARCHITECTS | INTERIOR DESIGNERS  
shared vision. innovative design.  
311 4th Street SW, P.O. Box 956, Willmar, MN 56201  
320-235-0860 FAX: 320-235-0861 | www.engan.com



Certification # Seal:

**PRELIMINARY**  
**NOT FOR CONSTRUCTION**

PROJECT # XXX.XX DATE: \_\_\_\_\_  
DRAWN BY: \_\_\_\_\_ CHECKED BY: \_\_\_\_\_  
OWNER: CLIENT NAME

Revision	Date

ROBBINGS ISLAND  
AMPHITHEATER

WILLMAR, MN

AUDIENCE VIEWS OF STAGE  
FROM PLAZA

A-209

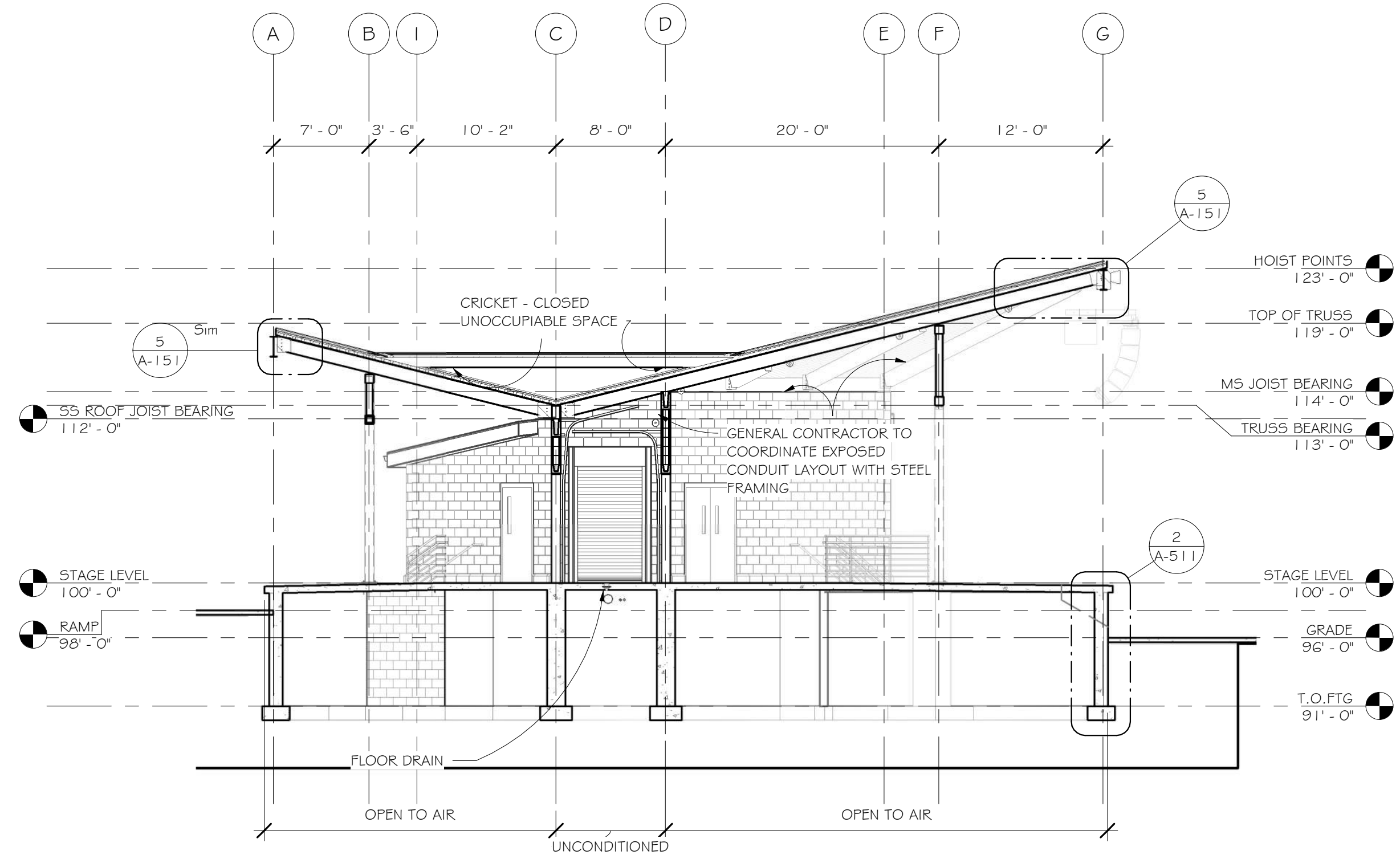

1 SMALL STAGE & MAINSTAGE TRANSVERSE SECTION

SCALE: 1/8" = 1'-0"  
1' 2' 4' 8'

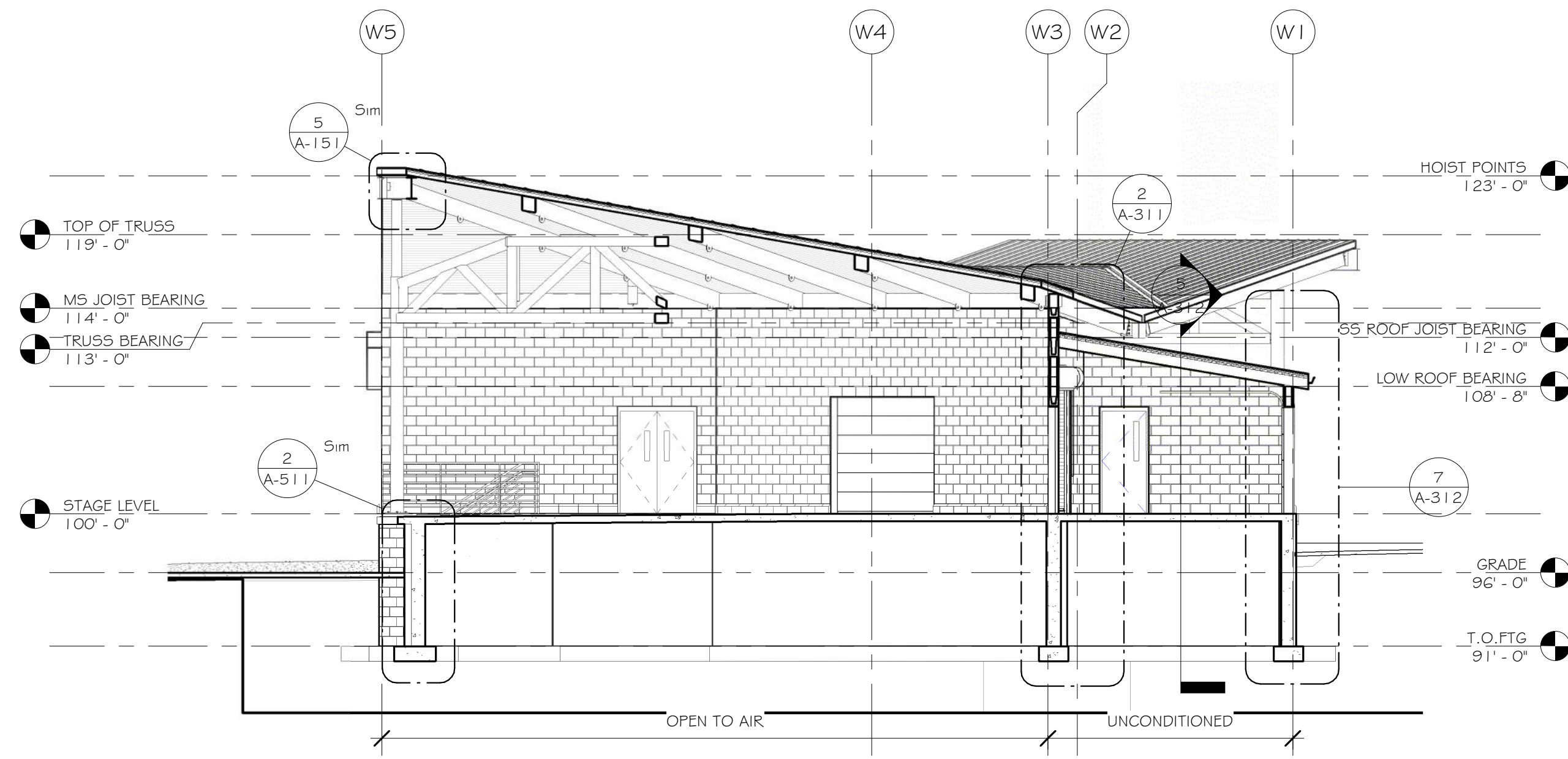

3 MAINSTAGE + STORAGE SECTION

SCALE: 1/8" = 1'-0"  
1' 2' 4' 8'

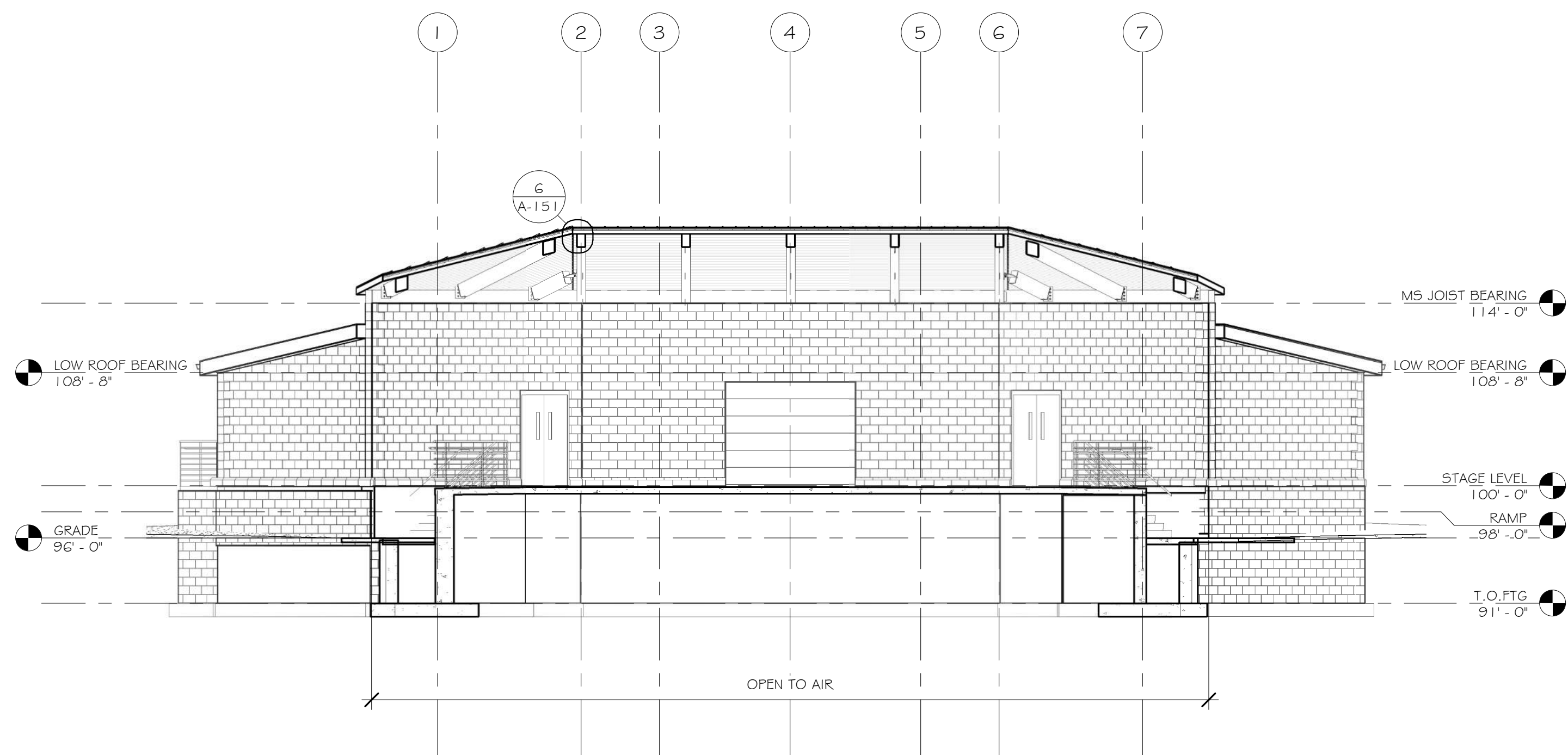

2 MAIN STAGE LONGITUDINAL SECTION

SCALE: 1/8" = 1'-0"  
1' 2' 4' 8'

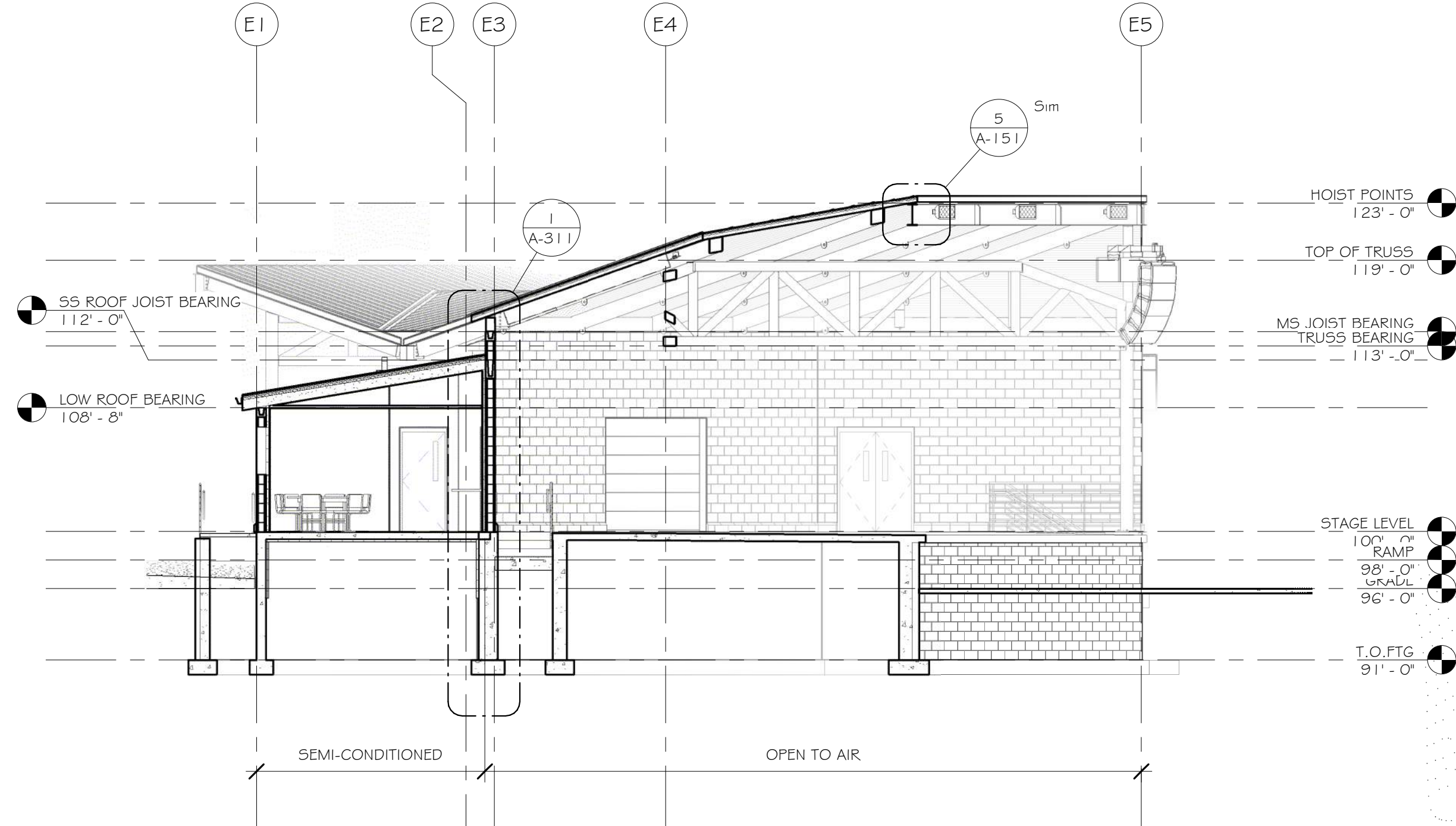

5 GREEN ROOM & MAIN STAGE SECTION

SCALE: 1/8" = 1'-0"  
1' 2' 4' 8'

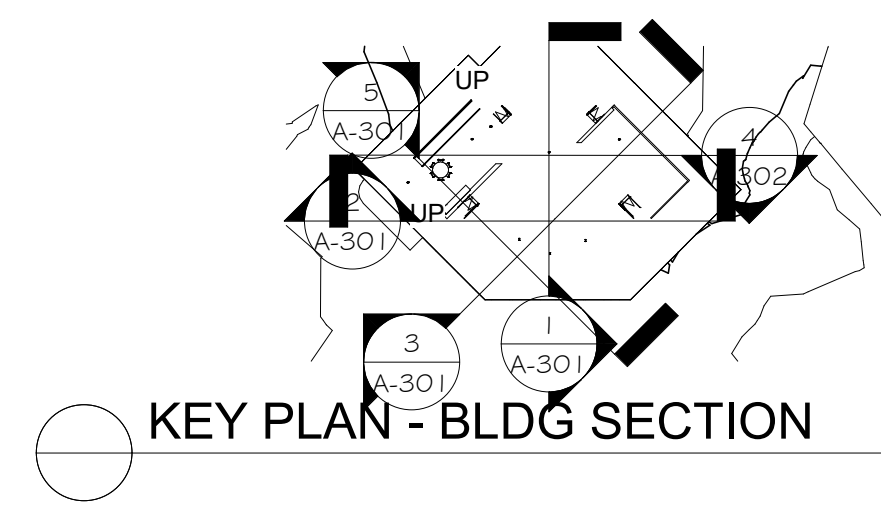

KEY PLAN - BLDG SECTION



**ENGAN ASSOCIATES**  
ARCHITECTS | INTERIOR DESIGNERS  
shared vision. innovative design.  
311 4th Street SW, P.O. Box 956, Willmar, MN 56201  
320-235-0860 FAX: 320-235-0861 | www.engan.com



STRUCTURAL ENGINEER  
Alexandria, MN  
320.808.4146 | www.AscheEngineering.com



Real People. Real Solutions.



Electrical Consulting Engineers  
Minneapolis, MN  
763.486.0965  
jeff@jbelectricaldesign.com



Certification # Seal:

**PRELIMINARY**  
**NOT FOR CONSTRUCTION**

PROJECT # XXX.XX DATE: --  
DRAWN BY: ??? CHECKED BY: ???  
OWNER: CLIENT NAME

Revision	Date

ROBBINS ISLAND  
AMPHITHEATER

WILLMAR, MN

MAIN STAGE BUILDING SECTIONS

A-301

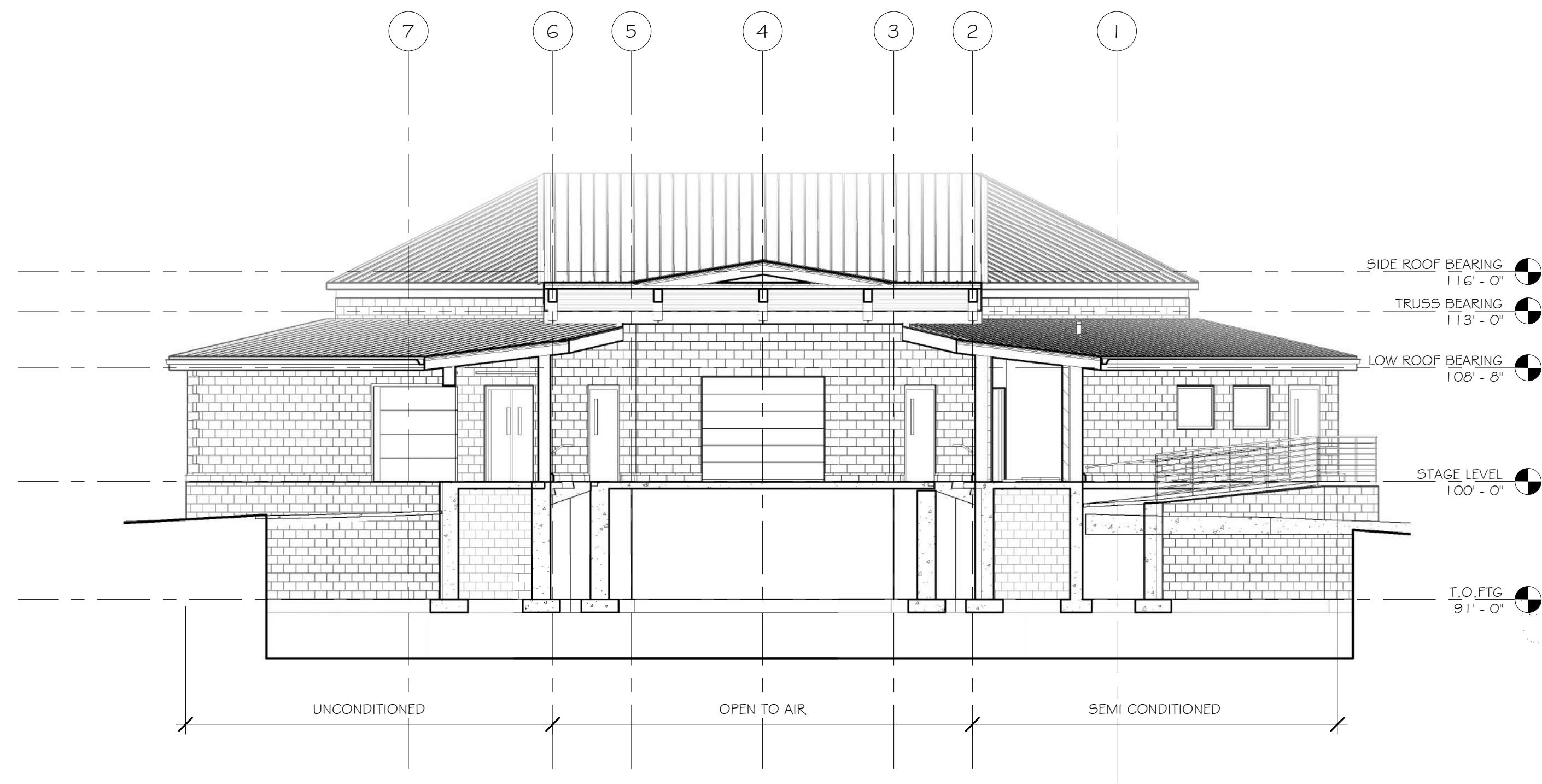

1 SMALL STAGE LONGITUDINAL SECTION  
 A-302 SCALE: 1/8" = 1'-0"  
 1' 2' 4' 8'

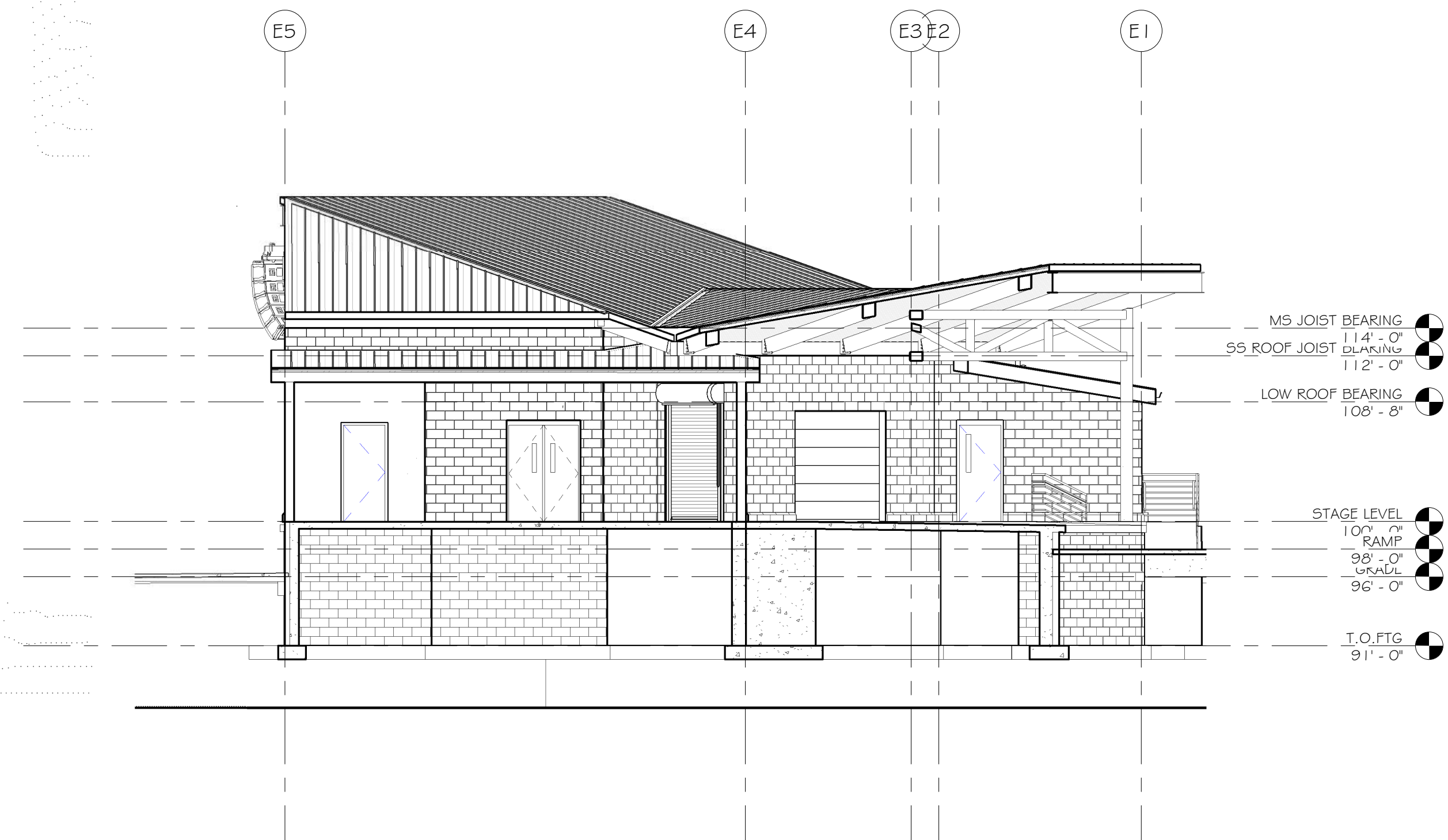

2 GREEN ROOM & SMALL STAGE SECTION  
 A-302 SCALE: 1/8" = 1'-0"  
 1' 2' 4' 8'

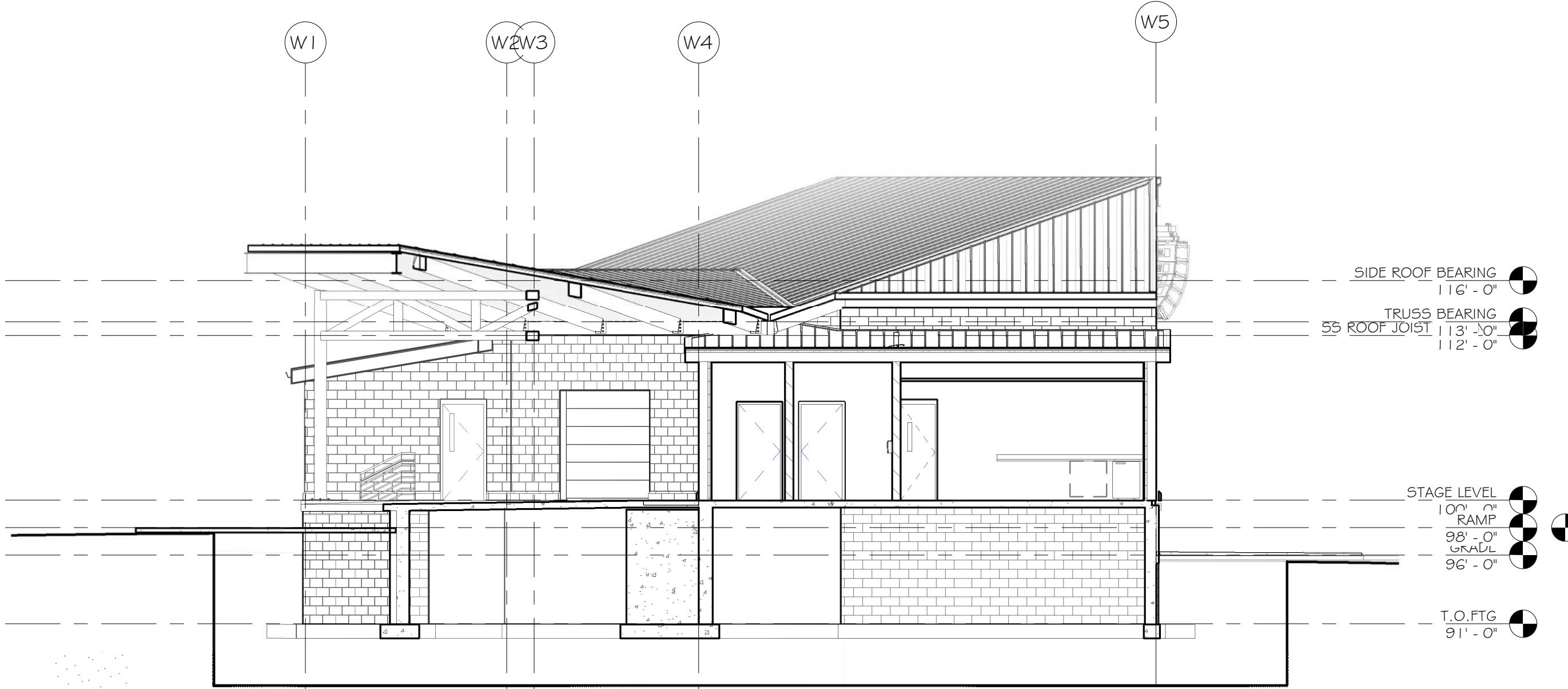

3 AMPITHEATRE & STORAGE SECTION  
 A-302 SCALE: 1/8" = 1'-0"  
 1' 2' 4' 8'



4 BACK STAGE LONGITUDINAL SECTION 1  
 A-302 SCALE: 1/8" = 1'-0"  
 1' 2' 4' 8'

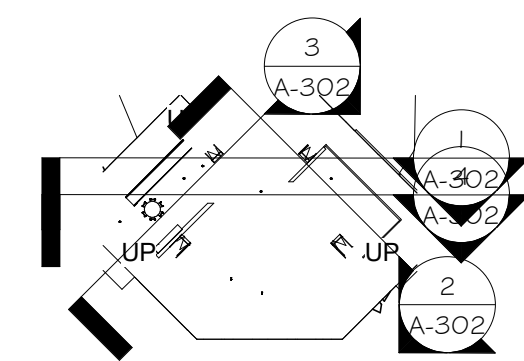

KEY PLAN - BLDG SECTION Copy 1



**ENGAN ASSOCIATES**  
 ARCHITECTS | INTERIOR DESIGNERS  
 shared vision. innovative design.  
 311 4th Street SW, P.O. Box 956, Willmar, MN 56201  
 320-235-0860 FAX: 320-235-0861 | www.engan.com



**BOLTON & MENK**  
 Real People. Real Solutions.



Certification & Seal:  
**PRELIMINARY**  
**NOT FOR CONSTRUCTION**

PROJECT #	XXX.XX	DATE:	
DRAWN BY:	???	CHECKED BY:	???
OWNER: CLIENT NAME			
Revision		Date	

ROBBINS ISLAND  
 AMPHITHEATER

WILLMAR, MN

AMPHITHEATRE SECTIONS

A-302



1 TYP. MAIN STAGE WALL  
A-311 SCALE: 1/2" = 1'-0" 3'6" 1' 2'

2 TYP. HMU FRAME IN CMU WALL  
A-311 SCALE: 1/2" = 1'-0" 3'6" 1' 2'

3 BACK STAGE DOORS SECTION  
A-311 SCALE: 1/2" = 1'-0" 3'6" 1' 2'

4 INTERIOR DOOR IN CMU  
A-311 SCALE: 1/2" = 1'-0" 3'6" 1' 2'

5 O.H. COILING DOOR IN CMU  
A-311 SCALE: 1/2" = 1'-0" 3'6" 1' 2'

WALL & ROOF NOTES

- WEATHER BARRIER - TYPICAL:**  
CONTINUOUS WATER AND AIR BARRIER AT THE EXTERIOR OF THE BUILDING - THIS IS A MEMBRANE UNDERNEATH THE EXTERIOR WALL SURFACE WHICH IS CONTINUOUS. THIS IS SEALED TO THE FOUNDATION AND ALL OPENINGS TO PREVENT THE ENTRANCE OF AIR AND WATER.
- THERMAL BARRIER - TYPICAL:**  
CONTINUOUS BARRIER AROUND THE BUILDING - THIS IS SEALED TO THE FOUNDATION, AND TO ALL OPENINGS.
- VAPOR BARRIER - TYPICAL:**  
CONTINUOUS BARRIER ON THE INTERIOR OF THE BUILDING - THIS SEALS TO THE FOUNDATION AND TO ALL OPENINGS.

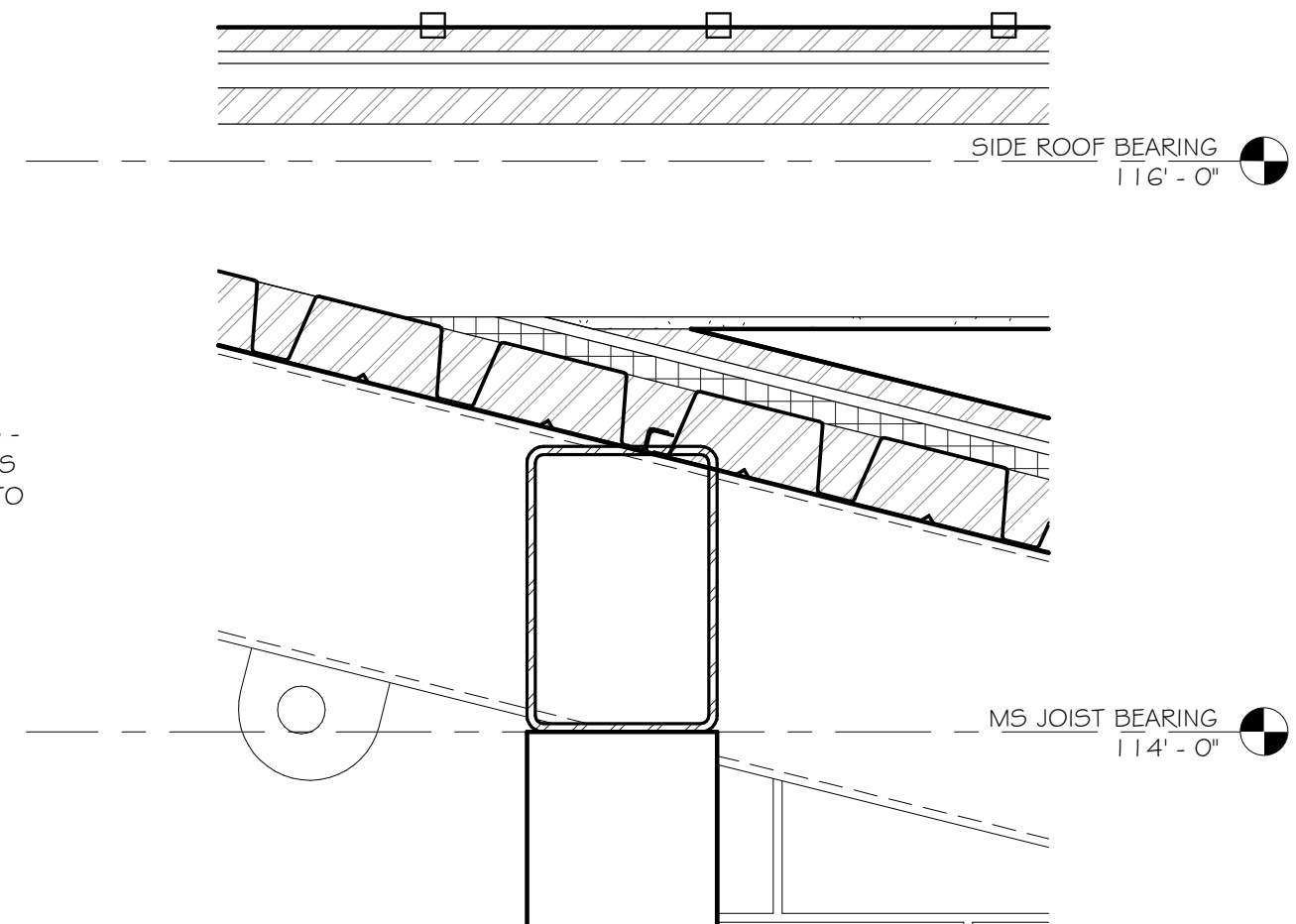

6 Detail 10  
A-311 SCALE: 1 1/2" = 1'-0" 1" 4" 8"

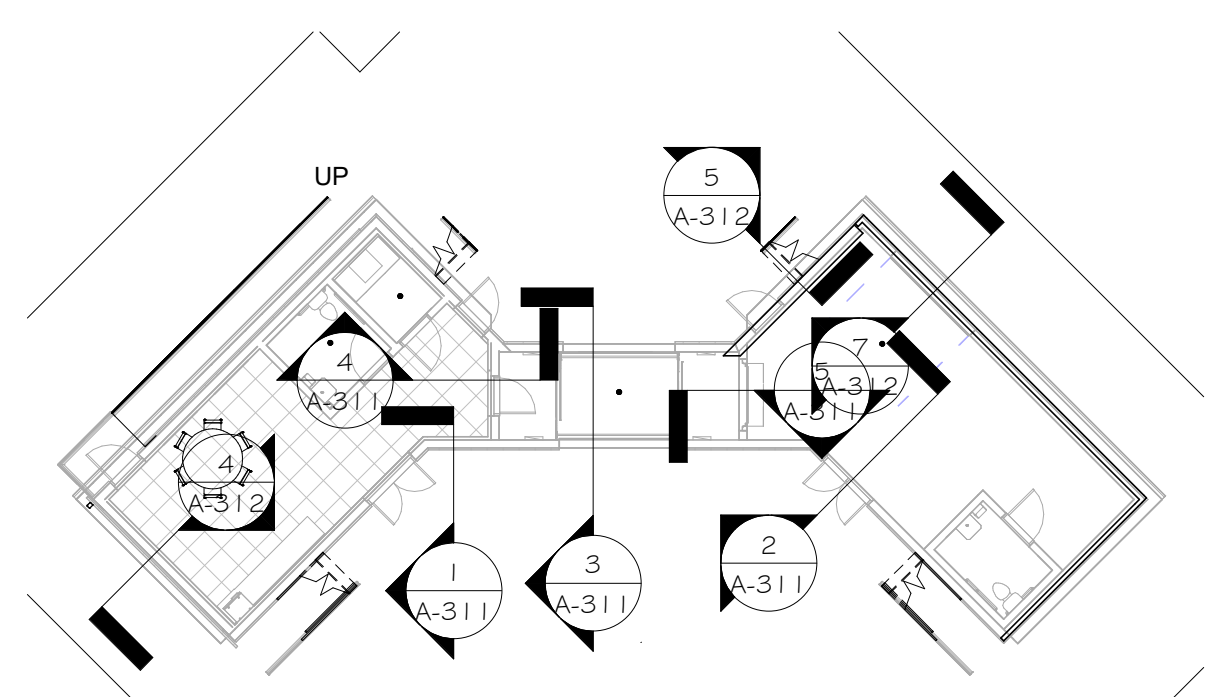

KEY PLAN - WALL SECTIONS

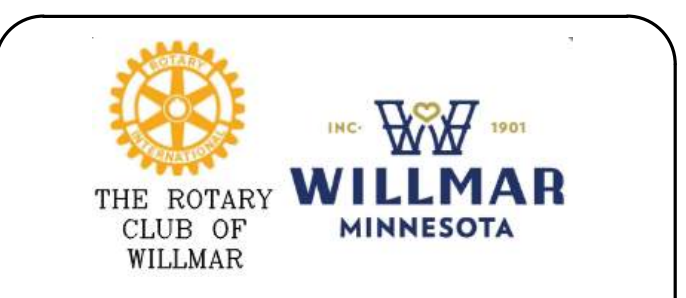

**ENGAN ASSOCIATES**  
ARCHITECTS | INTERIOR DESIGNERS  
shared vision. innovative design.  
311 4th Street SW, P.O. Box 956, Willmar, MN 56201  
320-235-0860 FAX: 320-235-0861 | www.engan.com



**BOLTON & MENK**  
Real People. Real Solutions.



Certification # Seal:  
**PRELIMINARY**  
**NOT FOR CONSTRUCTION**

PROJECT #	XXX,XX	DATE:	
DRAWN BY:	???	CHECKED BY:	???
OWNER: CLIENT NAME			
Revision		Date	

ROBBINS ISLAND AMPHITHEATER

WILLMAR, MN  
WALL SECTIONS - EXTERIOR

A-311

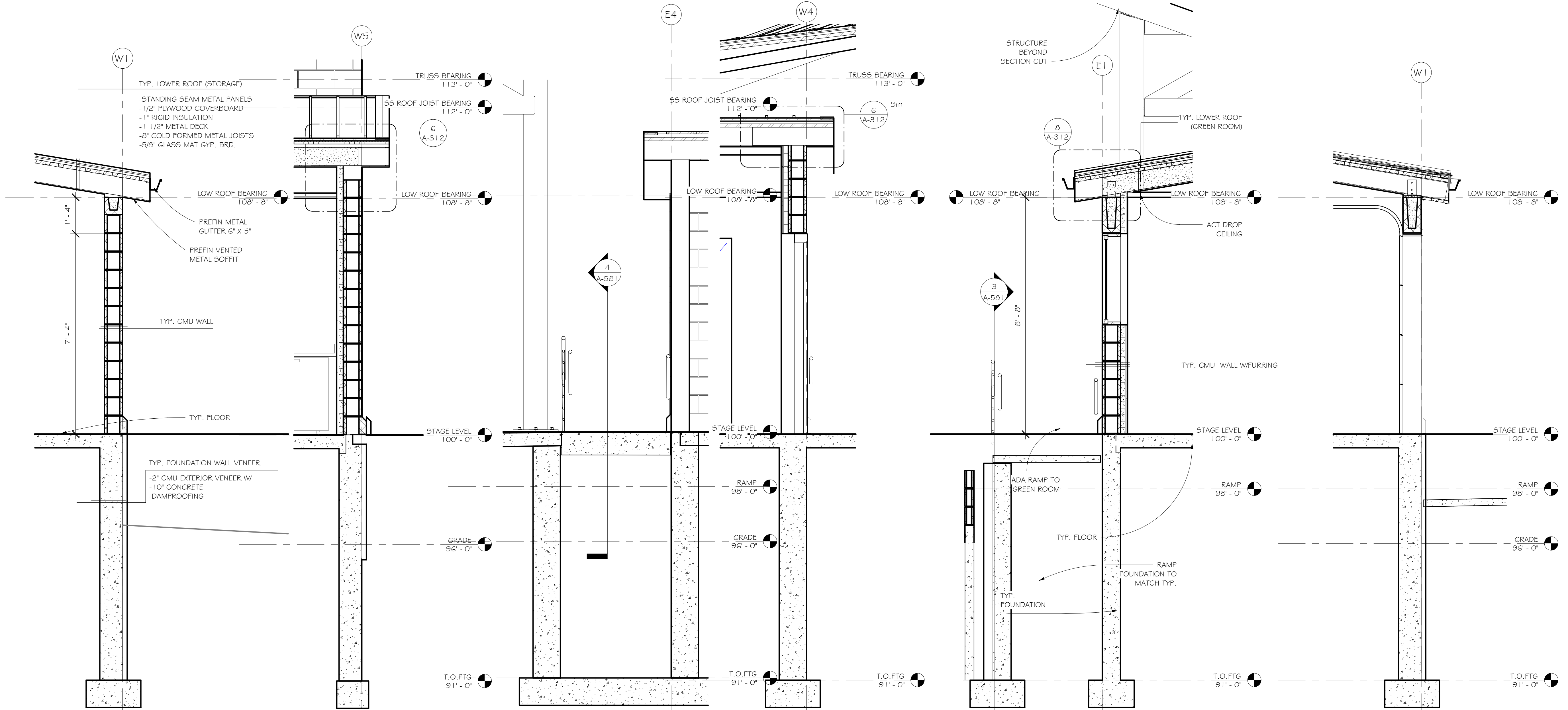

2 TYP. CMU WALL @ LOW EAVE  
A-312 SCALE: 1/2" = 1'-0"

4 Section 16  
A-312 SCALE: 1/2" = 1'-0"

5 TYP. SWING DOOR1  
A-312 SCALE: 1/2" = 1'-0"

3 TYP. SWING DOOR  
A-312 SCALE: 1/2" = 1'-0"

1 TYP. WINDOW IN CMU  
A-312 SCALE: 1/2" = 1'-0"

7 TYP WINDOW OPENING1  
A-312 SCALE: 1/2" = 1'-0"

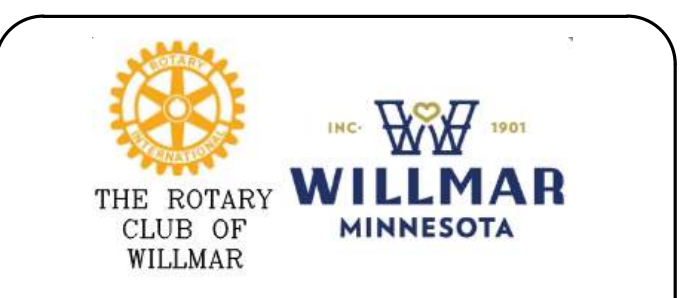
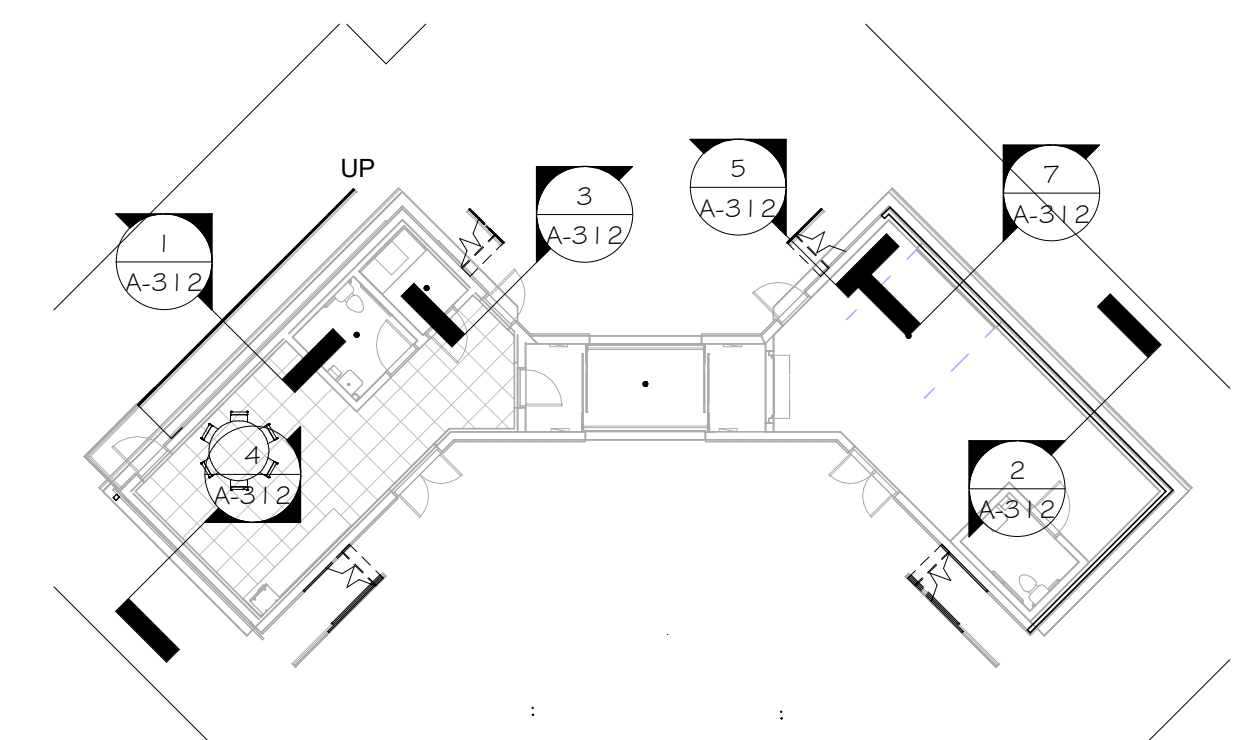
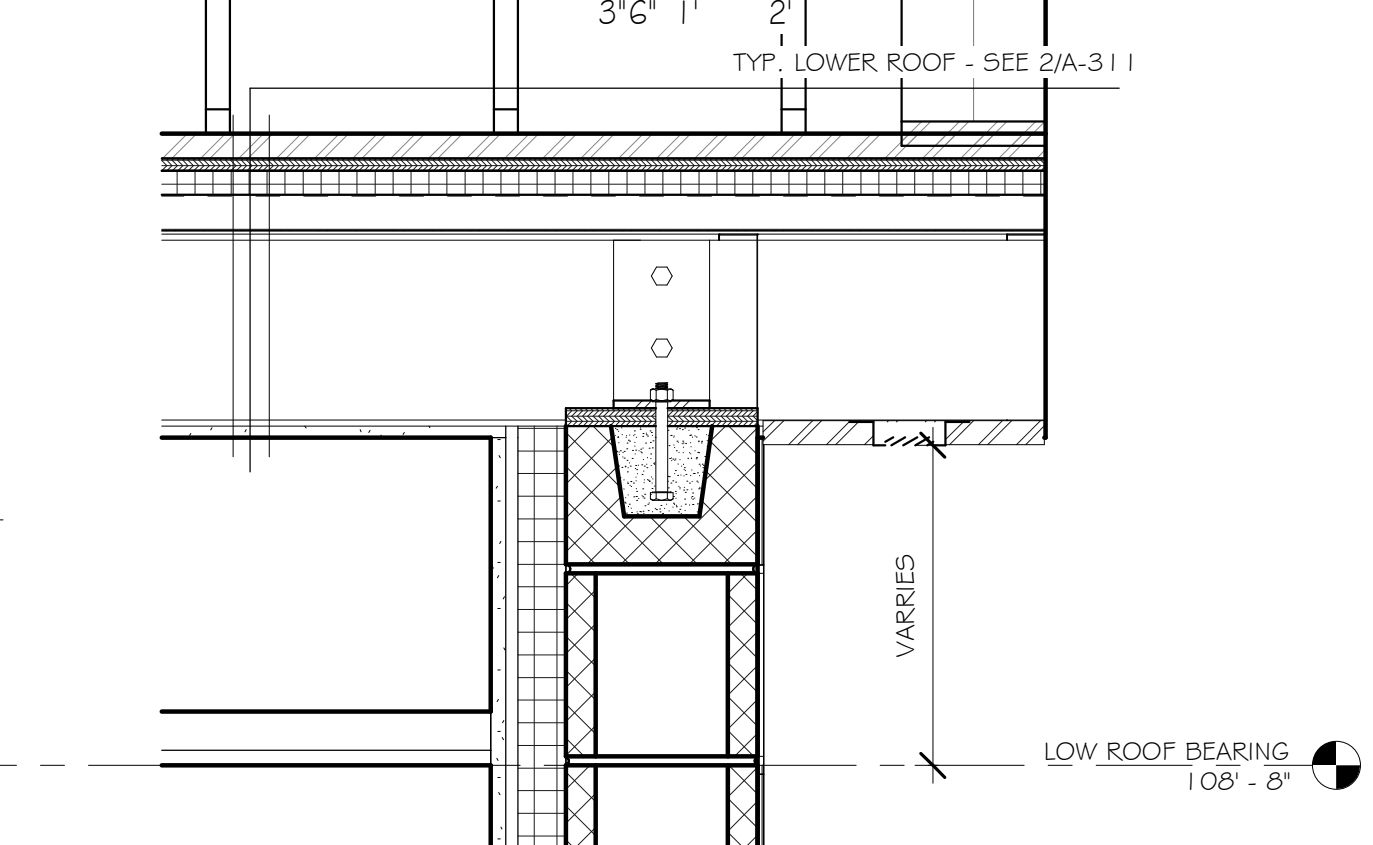
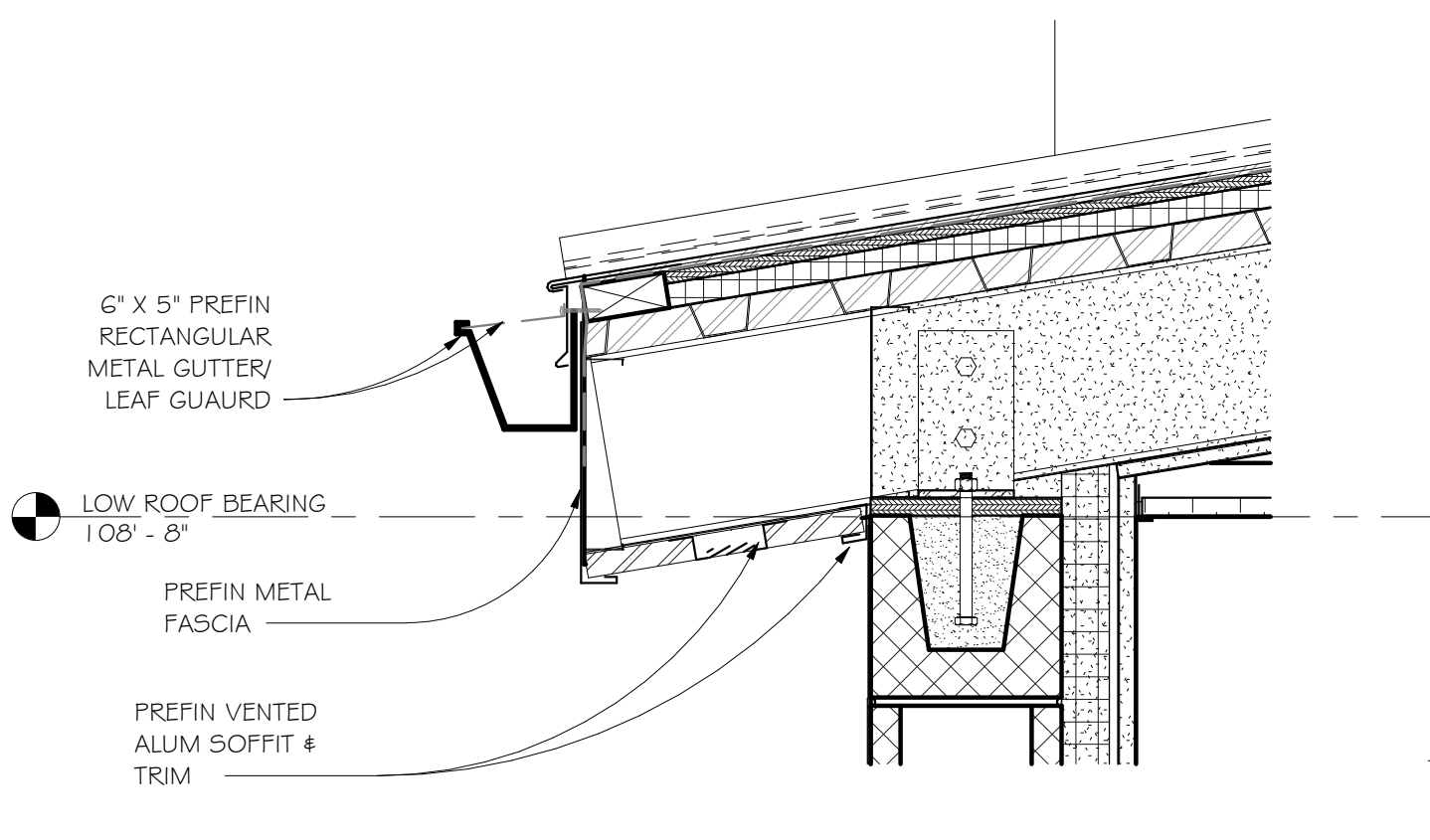

**ENGAN ASSOCIATES**  
ARCHITECTS | INTERIOR DESIGNERS  
shared vision. innovative design.  
311 4th Street SW, P.O. Box 956, Willmar, MN 56201  
320-235-0860 FAX: 320-235-0861 | www.engan.com



**JB Electrical Design, P.C.**  
Electrical Consulting Engineers  
Minneapolis, MN  
763.486.0965  
jeff@jbelectricaldesign.com



Certification # Seal:  
**PRELIMINARY**  
**NOT FOR CONSTRUCTION**

PROJECT #	XXX.XX	DATE:	
DRAWN BY:	???	CHECKED BY:	???
OWNER: CLIENT NAME			
Revision		Date	

ROBBINS ISLAND AMPHITHEATER

WILLMAR, MN

WALL SECTIONS

A-312

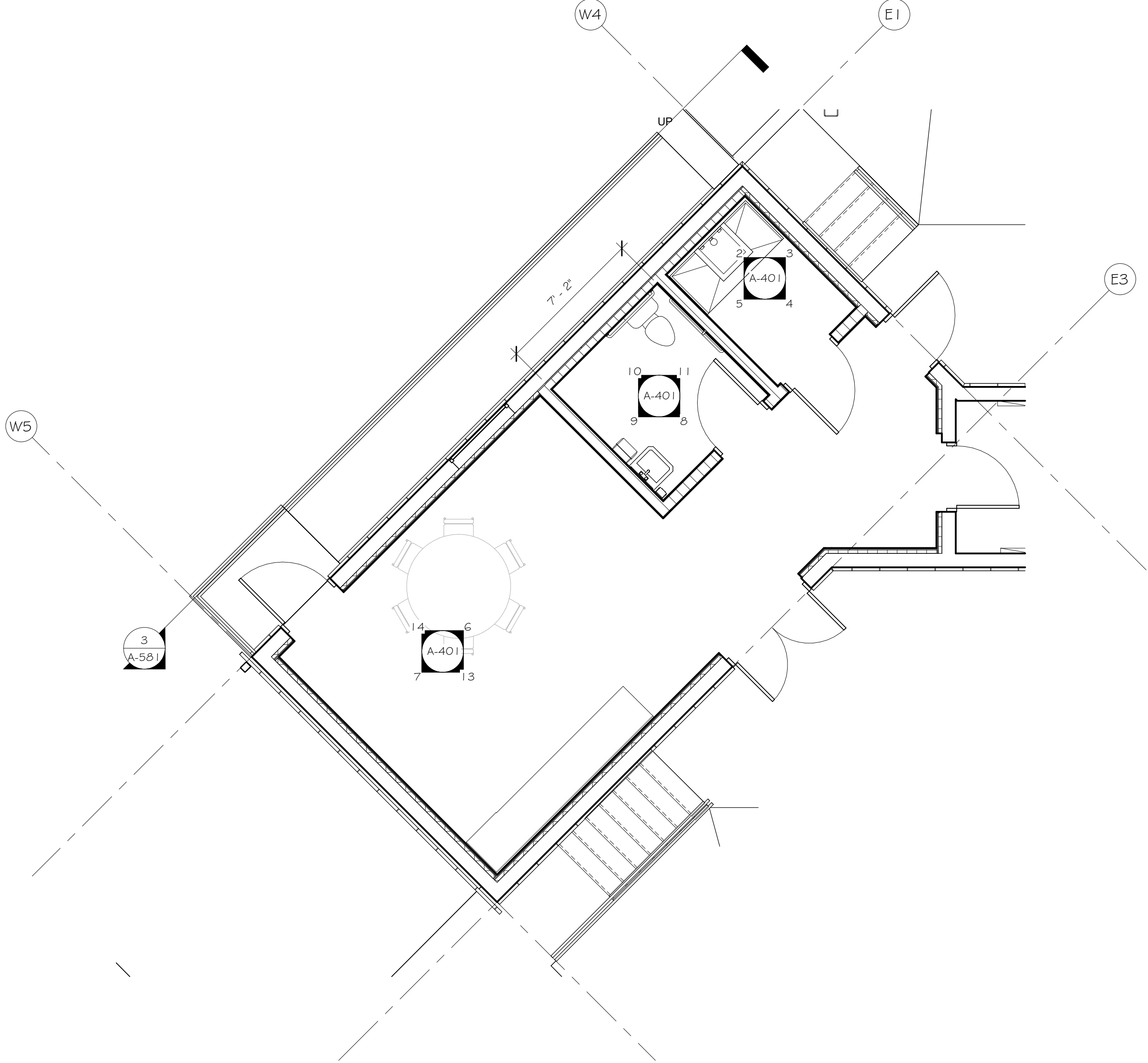

**1 MAIN LEVEL - ENLARGED NORTH PLAN**  
 A-401 SCALE: 1/4" = 1'-0"  
 6' 1' 2' 4'

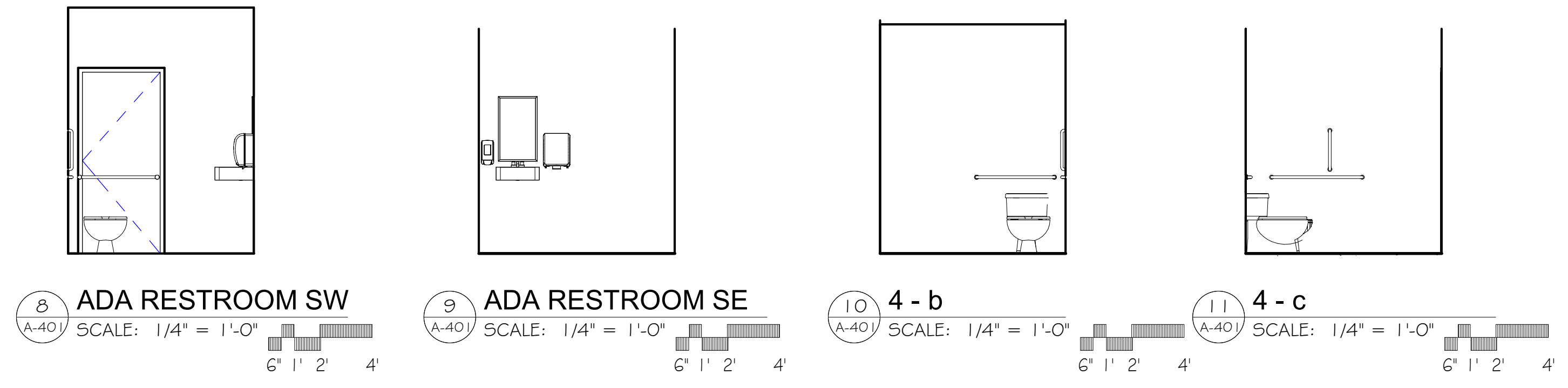

**8 ADA RESTROOM SW** A-401 SCALE: 1/4" = 1'-0"  
**9 ADA RESTROOM SE** A-401 SCALE: 1/4" = 1'-0"  
**10 4 - b** A-401 SCALE: 1/4" = 1'-0"  
**11 4 - c** A-401 SCALE: 1/4" = 1'-0"  
 6' 1' 2' 4'

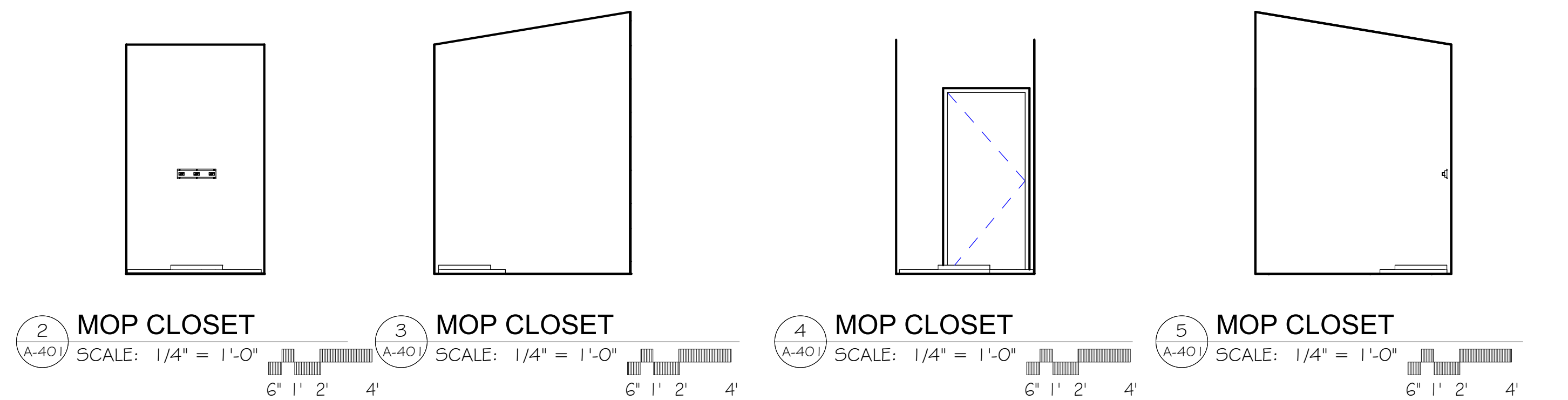

**2 MOP CLOSET** A-401 SCALE: 1/4" = 1'-0"  
**3 MOP CLOSET** A-401 SCALE: 1/4" = 1'-0"  
**4 MOP CLOSET** A-401 SCALE: 1/4" = 1'-0"  
**5 MOP CLOSET** A-401 SCALE: 1/4" = 1'-0"  
 6' 1' 2' 4'

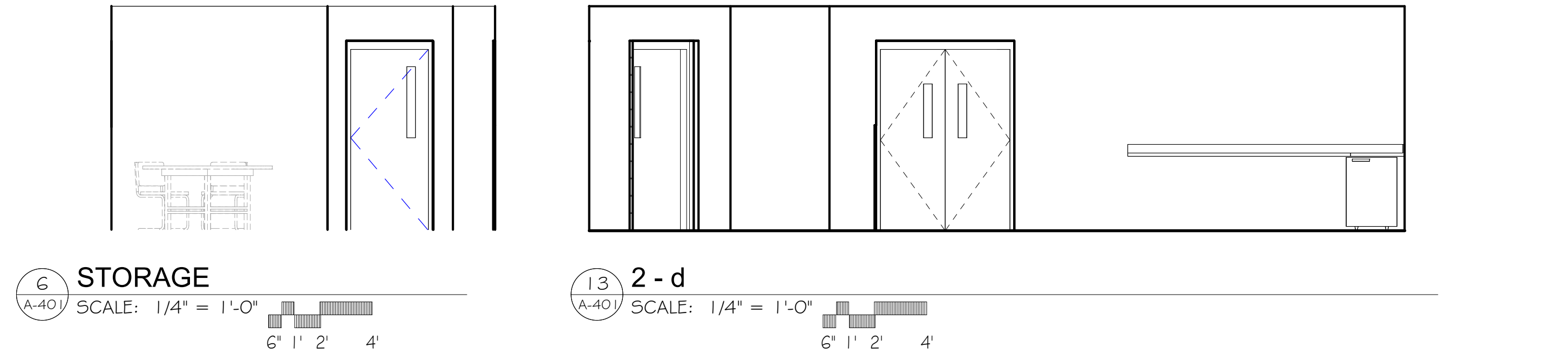

**6 STORAGE** A-401 SCALE: 1/4" = 1'-0"  
**13 2 - d** A-401 SCALE: 1/4" = 1'-0"  
 6' 1' 2' 4'

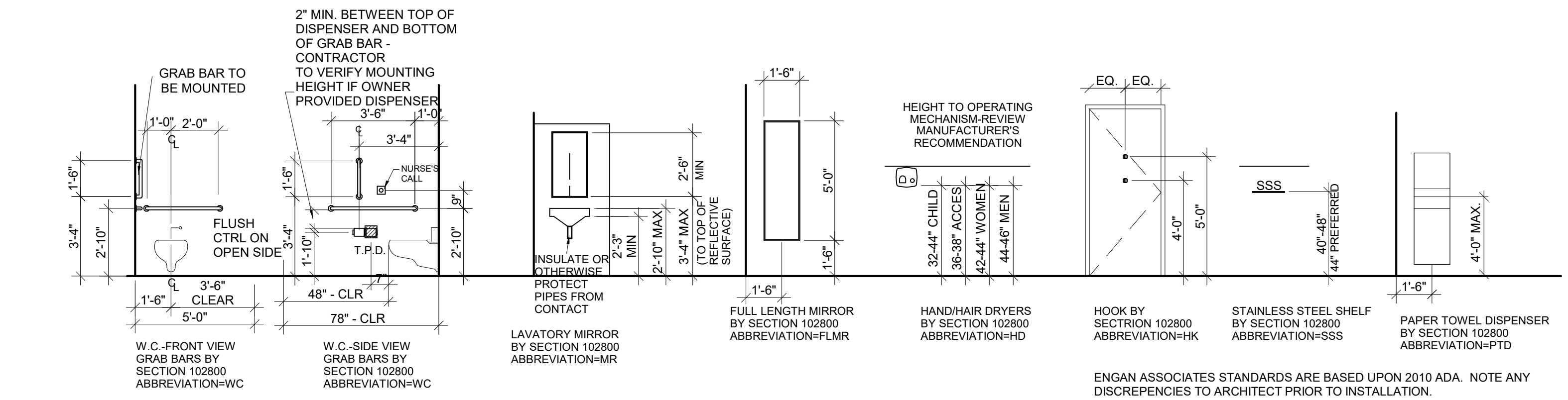

**12 STANDARD MOUNTING HTS**  
 A-401 SCALE: 1/4" = 1'-0"  
 6' 1' 2' 4'

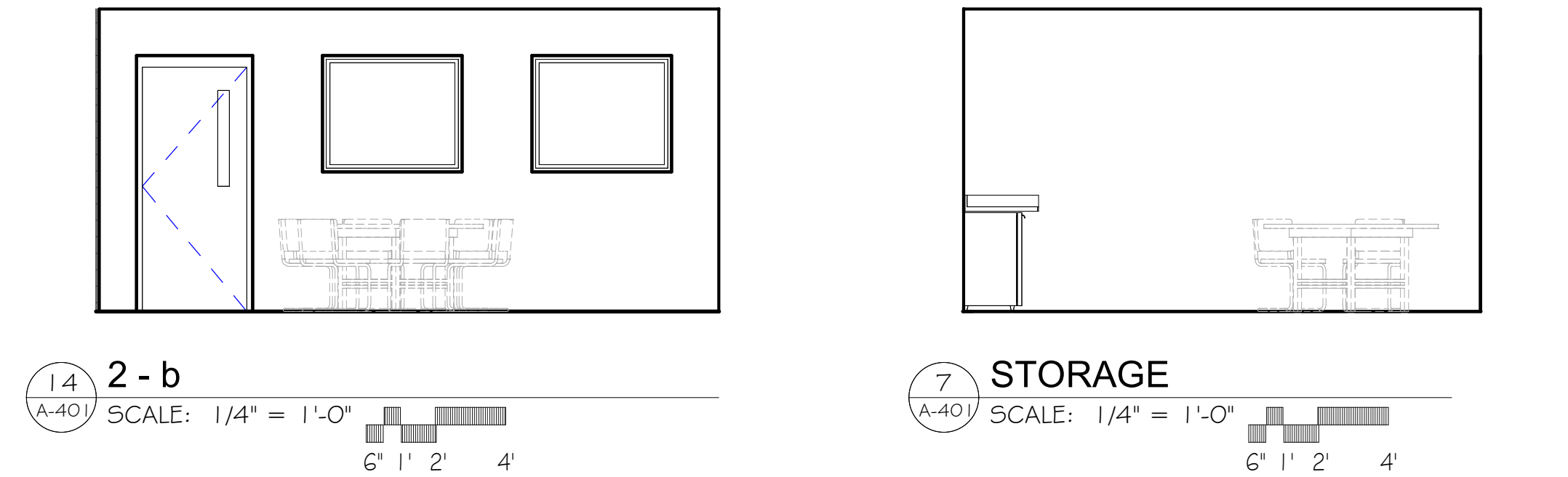

**14 2 - b** A-401 SCALE: 1/4" = 1'-0"  
**7 STORAGE** A-401 SCALE: 1/4" = 1'-0"  
 6' 1' 2' 4'

**THE ROTARY CLUB OF WILLMAR**  
 WILLMAR MINNESOTA

**ENGAN ASSOCIATES**  
 ARCHITECTS | INTERIOR DESIGNERS  
 shared vision. innovative design.  
 311 4th Street SW, P.O. Box 956, Willmar, MN 56201  
 320-235-0860 FAX: 320-235-0861 | www.engan.com

**ASCHE ENGINEERING**  
 STRUCTURAL ENGINEER  
 Alexandria, MN  
 320.808.4146 | www.AscheEngineering.com

**BOLTON & MENK**  
 Real People. Real Solutions.

**JB Electrical Design, P.C.**  
 Electrical Consulting Engineers  
 Minneapolis, MN  
 763.486.0965  
 jeff@jbelectricaldesign.com

**MARTIN MECHANICAL DESIGN INC.**

Certification # Seal:

**PRELIMINARY**  
 NOT FOR CONSTRUCTION

PROJECT # XXX.XX DATE: -  
 DRAWN BY: ??? CHECKED BY: ???  
 OWNER: CLIENT NAME

Revision | Date

**ROBBINS ISLAND AMPHITHEATER**

**WILLMAR, MN**

INTERIOR ELEVATIONS

**A-401**



**ENGAN ASSOCIATES**  
 ARCHITECTS | INTERIOR DESIGNERS  
 shared vision. innovative design.  
 311 4th Street SW, P.O. Box 956, Willmar, MN 56201  
 320-235-0860 FAX: 320-235-0861 | www.engan.com



Certification # Seal:

**PRELIMINARY**  
**NOT FOR CONSTRUCTION**

PROJECT # XXX.XX DATE: \_\_\_\_\_  
 DRAWN BY: \_\_\_\_\_ CHECKED BY: \_\_\_\_\_  
 OWNER: CLIENT NAME

Revision	Date

ROBBINS ISLAND  
 AMPHITHEATER

WILLMAR, MN  
 EXTERIOR RENDERINGS

A-203

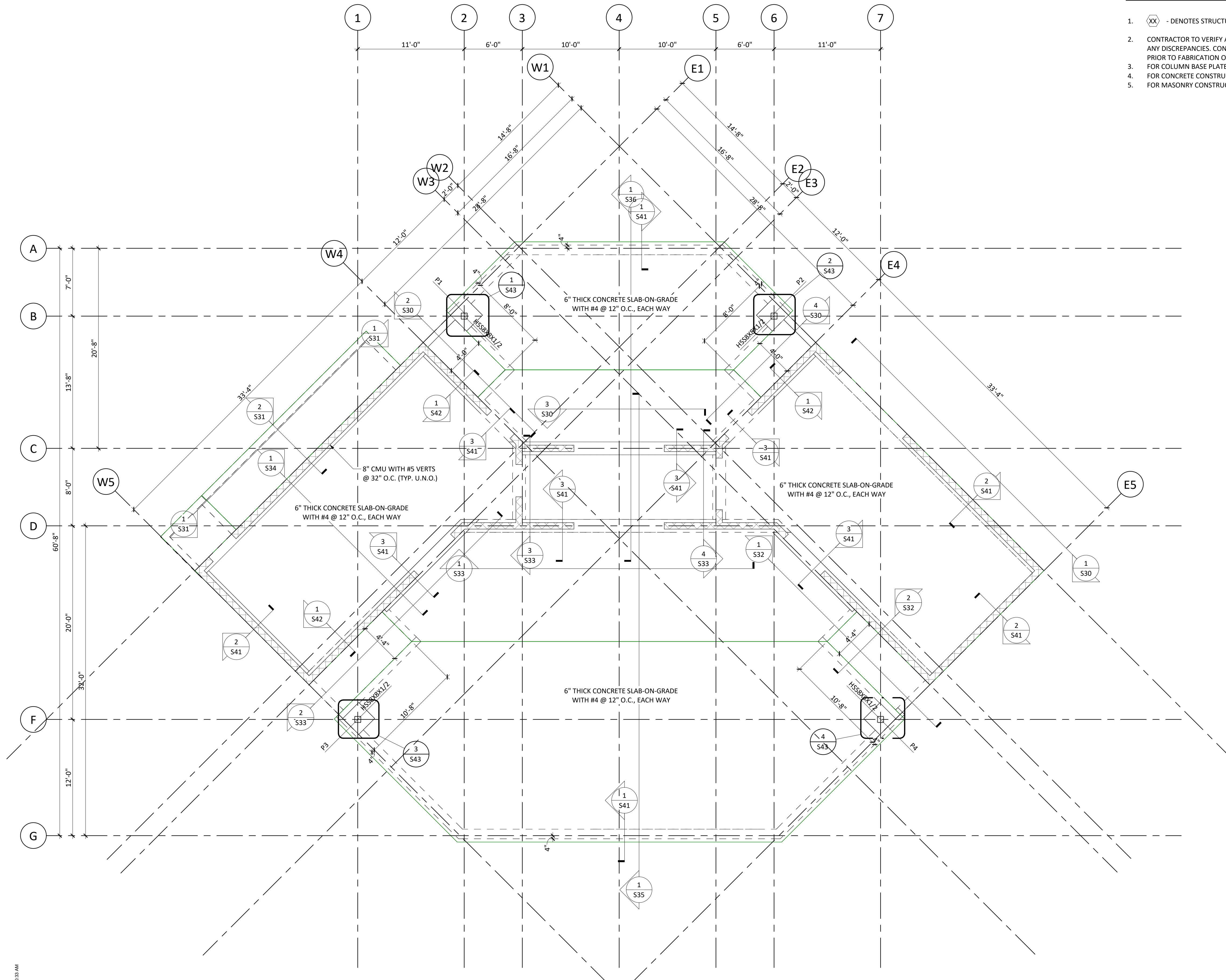

**MAIN FLOOR PLAN NOTES (STRUCTURAL STEEL FRAME)**

1. (XX) - DENOTES STRUCTURAL KEYNOTES, SEE DRAWING S11
2. CONTRACTOR TO VERIFY ALL DIMENSIONS, AND NOTIFY ARCHITECT/ENGINEER OF ANY DISCREPANCIES. CONTRACTOR TO FIELD VERIFY EXISTING CONDITIONS AND DIMENSIONS PRIOR TO FABRICATION OF NEW MATERIALS AND CONSTRUCTION
3. FOR COLUMN BASE PLATES, SEE DETAIL 1/S63
4. FOR CONCRETE CONSTRUCTION DETAILS, SEE DRAWING S60
5. FOR MASONRY CONSTRUCTION DETAILS, SEE DRAWING S61 ~ S62

1 MAIN FLOOR PLAN  
S21 SCALE: 3/16" = 1'-0"

3/1/2026 11:45:33 AM



**ENGAN ASSOCIATES**  
ARCHITECTS | INTERIOR DESIGNERS  
shared vision. innovative design.  
311 4th Street SW, P.O. Box 956, Willmar, MN 56201  
320-235-0860 FAX: 320-235-0861 | www.engan.com



Certification & Seal:

**PRELIMINARY**  
NOT FOR CONSTRUCTION

PROJECT # AE23012 DATE: 03-31-2026  
DRAWN BY: BA CHECKED BY: BA  
OWNER:

Revision	Date

**ROBBINS ISLAND  
REGIONAL PARK  
AMPHITHEATER**

**WILLMAR, MN**  
MAIN FLOOR PLAN

**S21**

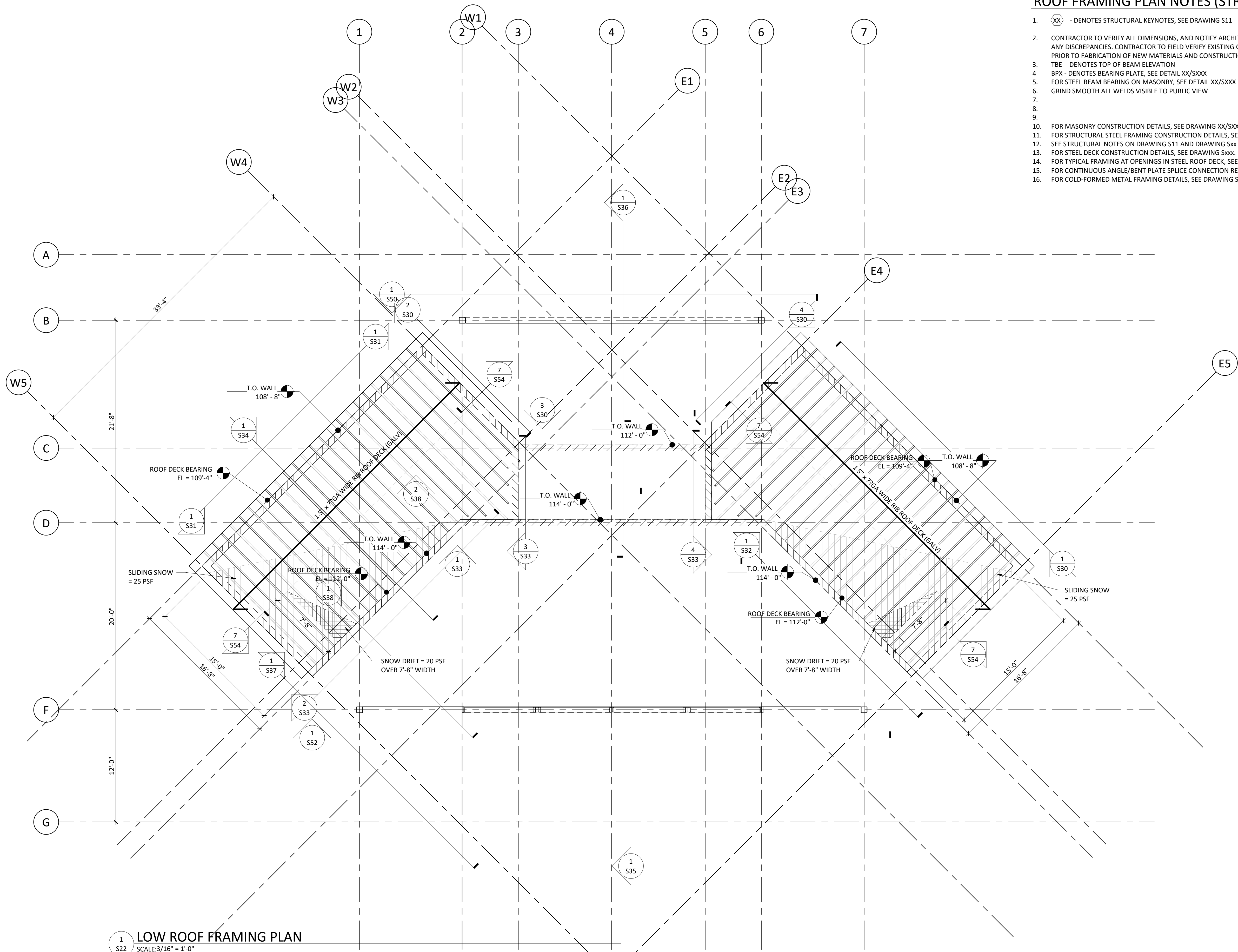

**ROOF FRAMING PLAN NOTES (STRUCTURAL STEEL FRAME)**

1. (XX) - DENOTES STRUCTURAL KEYNOTES, SEE DRAWING S11
2. CONTRACTOR TO VERIFY ALL DIMENSIONS, AND NOTIFY ARCHITECT/ENGINEER OF ANY DISCREPANCIES. CONTRACTOR TO FIELD VERIFY EXISTING CONDITIONS AND DIMENSIONS PRIOR TO FABRICATION OF NEW MATERIALS AND CONSTRUCTION
3. TBE - DENOTES TOP OF BEAM ELEVATION
4. BPX - DENOTES BEARING PLATE, SEE DETAIL XX/SXXX
5. FOR STEEL BEAM BEARING ON MASONRY, SEE DETAIL XX/SXXX
6. GRIND SMOOTH ALL WELDS VISIBLE TO PUBLIC VIEW
- 7.
- 8.
- 9.
10. FOR MASONRY CONSTRUCTION DETAILS, SEE DRAWING XX/SXXX
11. FOR STRUCTURAL STEEL FRAMING CONSTRUCTION DETAILS, SEE DRAWING SXXX
12. SEE STRUCTURAL NOTES ON DRAWING S11 AND DRAWING Sxx FOR ROOF DECK FASTENING REQUIREMENTS.
13. FOR STEEL DECK CONSTRUCTION DETAILS, SEE DRAWING Sxxx.
14. FOR TYPICAL FRAMING AT OPENINGS IN STEEL ROOF DECK, SEE DETAIL X/Sxxx
15. FOR CONTINUOUS ANGLE/BENT PLATE SPLICE CONNECTION REQUIREMENTS, SEE DETAIL xx/Sxxx
16. FOR COLD-FORMED METAL FRAMING DETAILS, SEE DRAWING Sxxx

**1**  
S22  
**LOW ROOF FRAMING PLAN**  
SCALE: 3/16" = 1'-0"



**ENGAN ASSOCIATES**  
ARCHITECTS | INTERIOR DESIGNERS  
shared vision. innovative design.  
311 4th Street SW, P.O. Box 956, Willmar, MN 56201  
320-235-0860 FAX: 320-235-0861 | www.engan.com

**ASCE ENGINEERING**  
STRUCTURAL ENGINEER  
Alexandria, MN  
320.808.4146 | www.AsceEngineering.com

**JB Electrical Design, P.C.**  
Electrical Consulting Engineers  
Minneapolis, MN  
763.486.0965  
jeff@jbelectricaldesign.com



Certification & Seal:  
**PRELIMINARY**  
NOT FOR CONSTRUCTION

PROJECT #	AE23012	DATE:	03-31-2026
DRAWN BY:	BA	CHECKED BY:	BA
OWNER			
Revision	Date		

**ROBBINS ISLAND REGIONAL PARK AMPHITHEATER**

**WILLMAR, MN**  
LOW ROOF FRAMING PLAN

**S22**

Certification & Seal:

**PRELIMINARY**  
 NOT FOR CONSTRUCTION

PROJECT # AE23012 DATE: 03-31-2026  
 DRAWN BY: BA CHECKED BY: BA  
 OWNER:

Revision	Date

ROBBINS ISLAND REGIONAL PARK AMPHITHEATER

WILLMAR, MN  
 HIGH ROOF FRAMING PLAN

S23

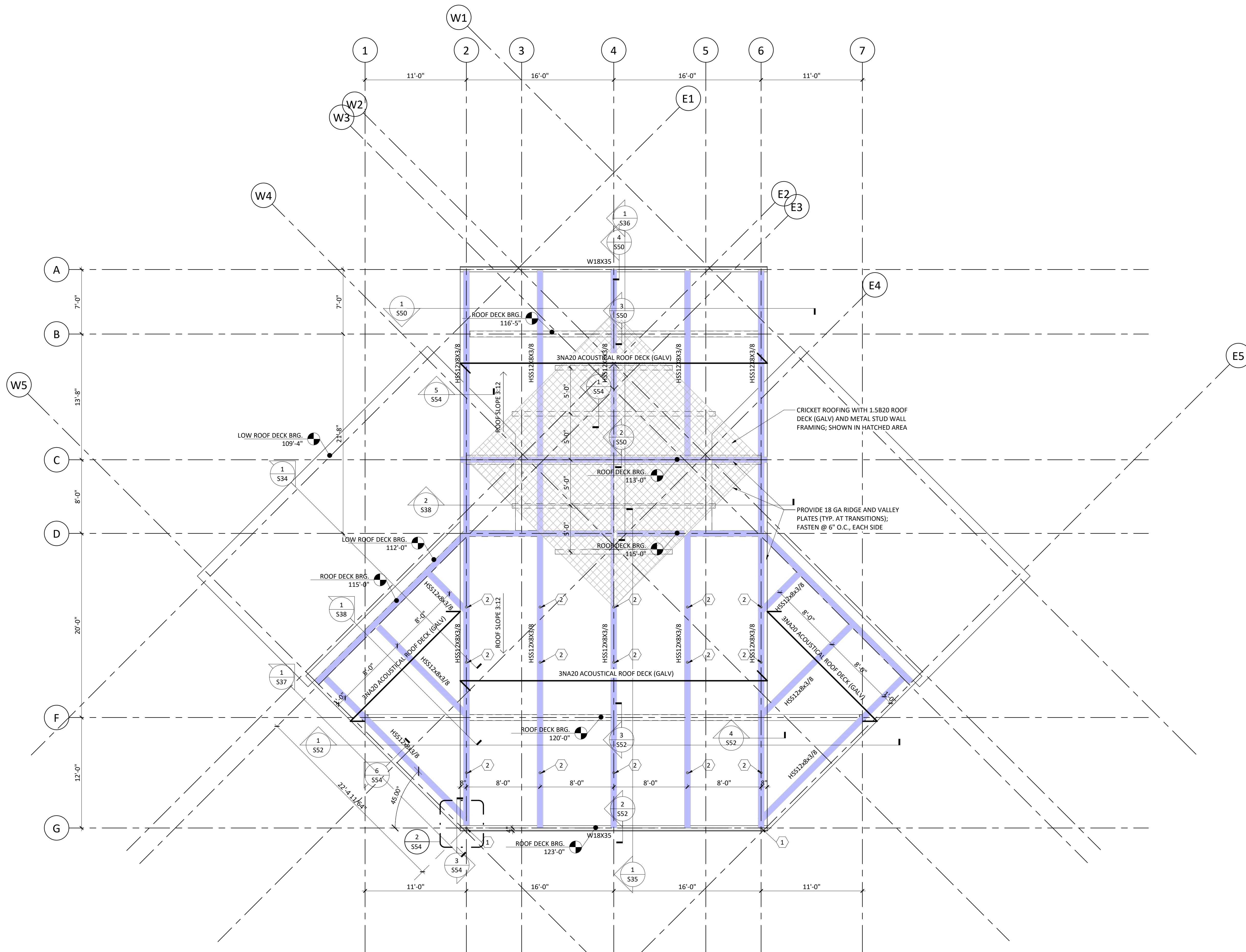

1 HIGH ROOF FRAMING PLAN  
 S23 SCALE: 3/16" = 1'-0"

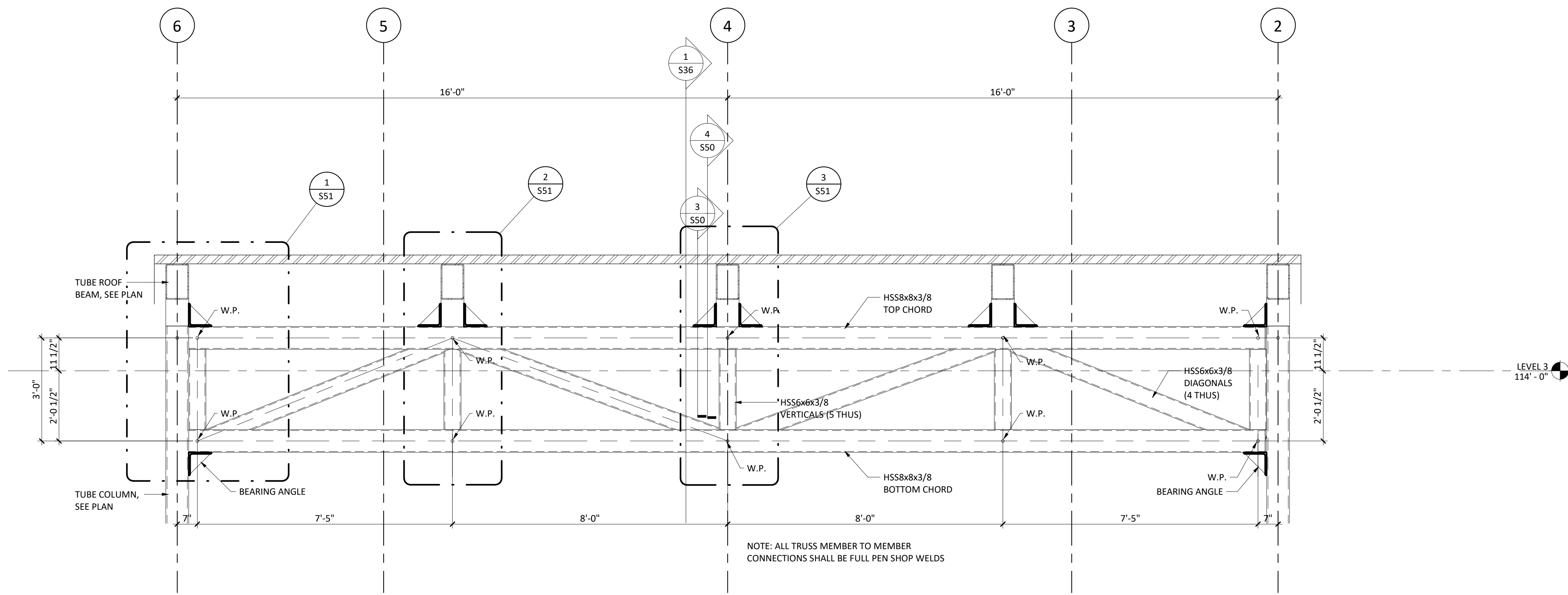

1 BACK STAGE - TRUSS ELEVATION  
SCALE: 1/2" = 1'-0"

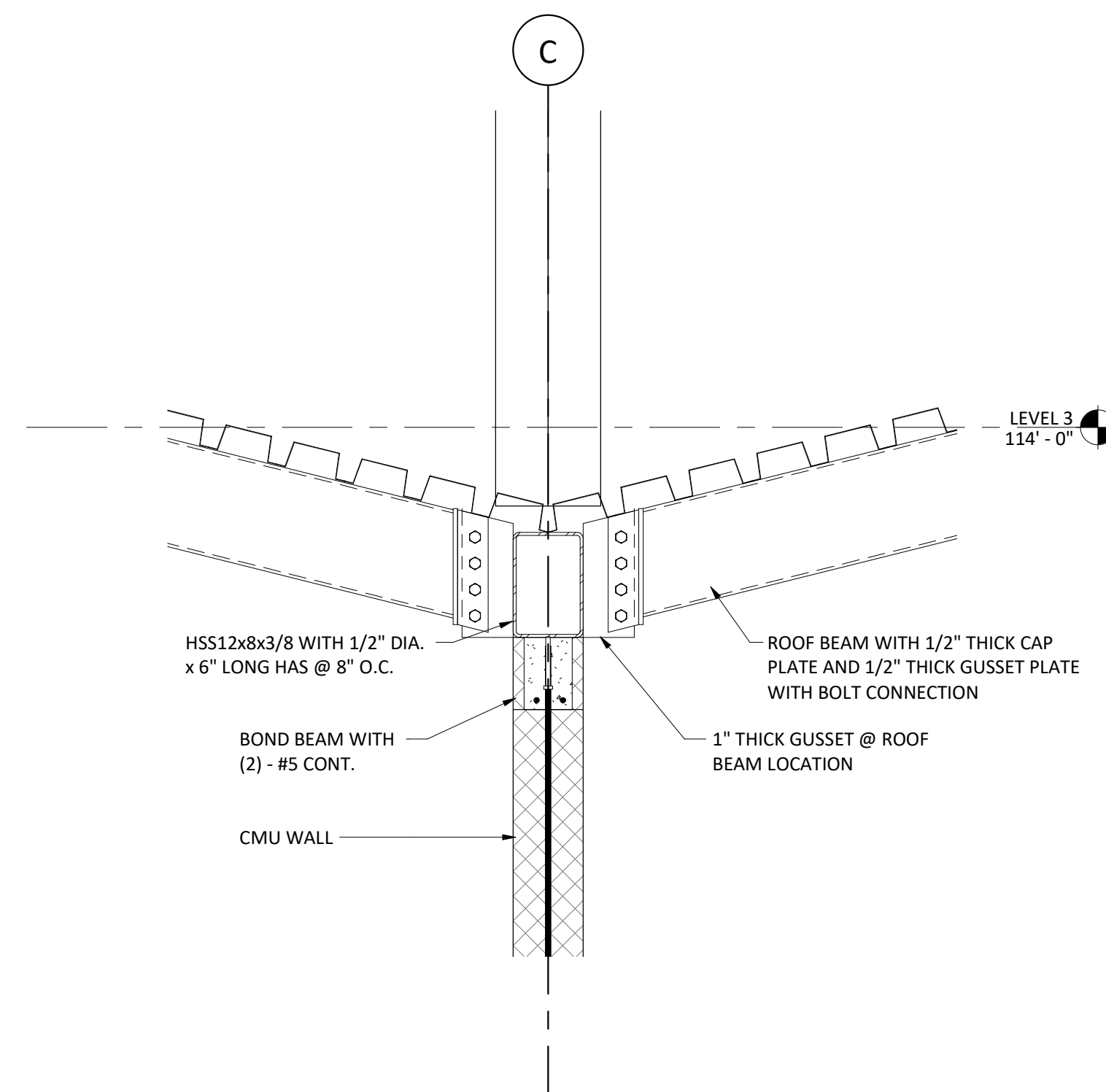

2 DETAIL - STAGE ROOFS  
SCALE: 3/4" = 1'-0"

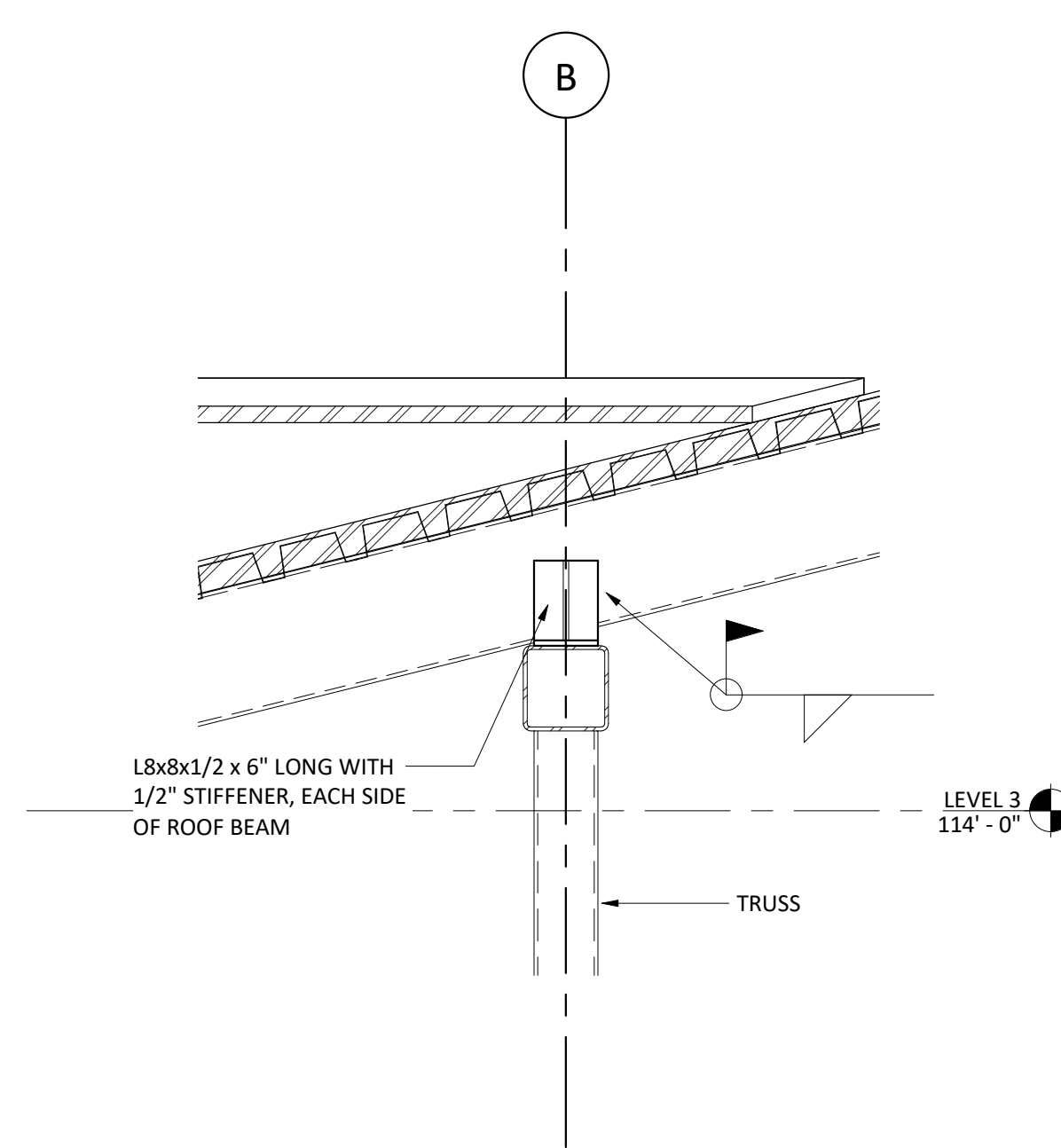

3 DETAIL - BACK STAGE  
SCALE: 3/4" = 1'-0"

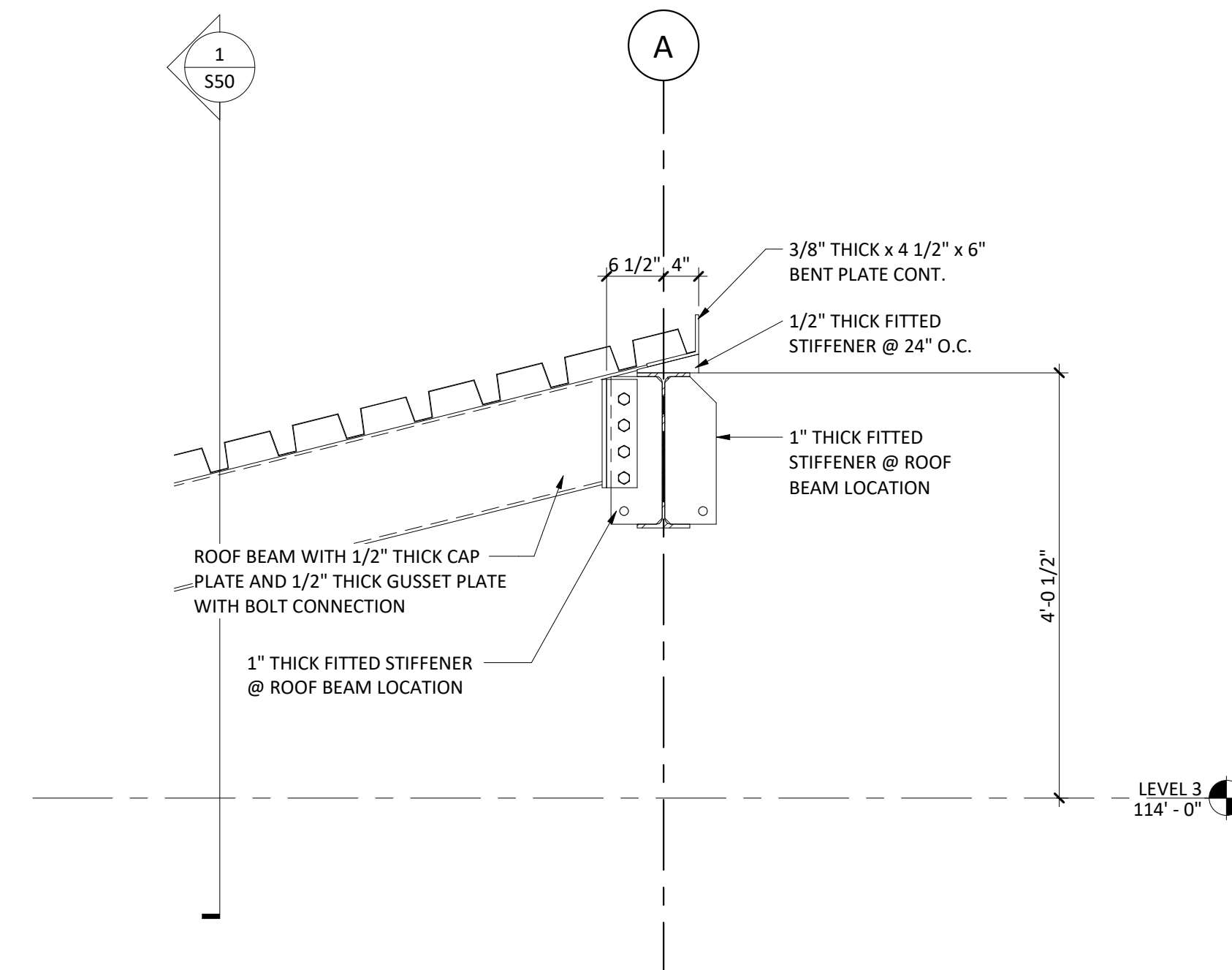

4 DETAIL - BACK STAGE  
SCALE: 3/4" = 1'-0"

**ENGAN ASSOCIATES**  
 ARCHITECTS | INTERIOR DESIGNERS  
 shared vision. innovative design.  
 311 4th Street SW, P.O. Box 956, Willmar, MN 56201  
 320-235-0860 FAX: 320-235-0861 | www.engan.com

**ASCE ENGINEERING**  
 STRUCTURAL ENGINEER  
 Alexandria, MN  
 320.808.4146 | www.AsceEngineering.com

**JB Electrical Design, P.C.**  
 Electrical Consulting Engineers  
 Minneapolis, MN  
 763.486.0965  
 jeff@jbelectricaldesign.com

**MARTIN MECHANICAL DESIGN, INC.**

Certification & Seal:

**PRELIMINARY**

NOT FOR CONSTRUCTION

PROJECT #	AE23012	DATE:	03-31-2026
DRAWN BY:	BA	CHECKED BY:	BA
OWNER			
Revision	Date		

**ROBBINS ISLAND REGIONAL PARK AMPHITHEATER**  
  
**WILLMAR, MN**  
 SECTIONS AND ELEVATIONS

**S50**

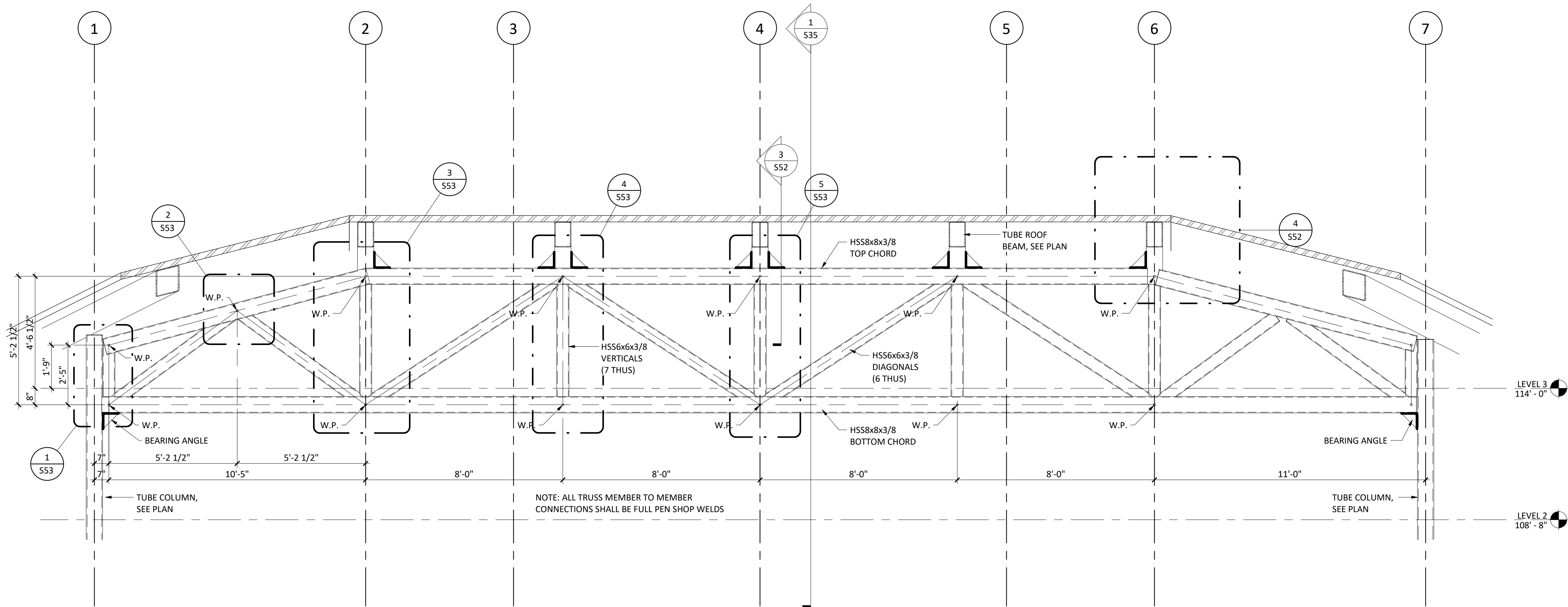

1 MAIN STAGE - TRUSS ELEVATION  
SCALE: 3/8" = 1'-0"

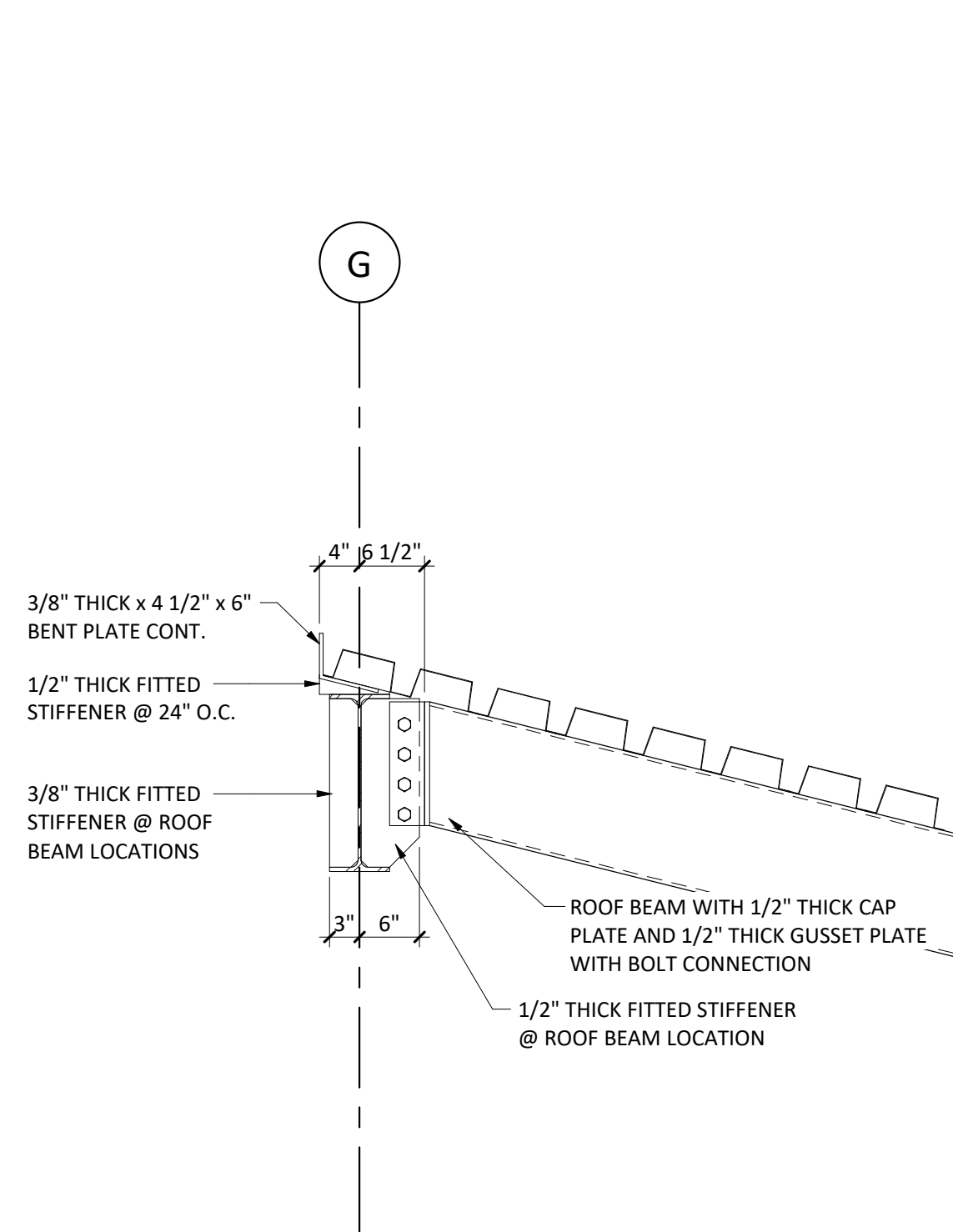

2 DETAIL - MAIN STAGE  
SCALE: 3/4" = 1'-0"

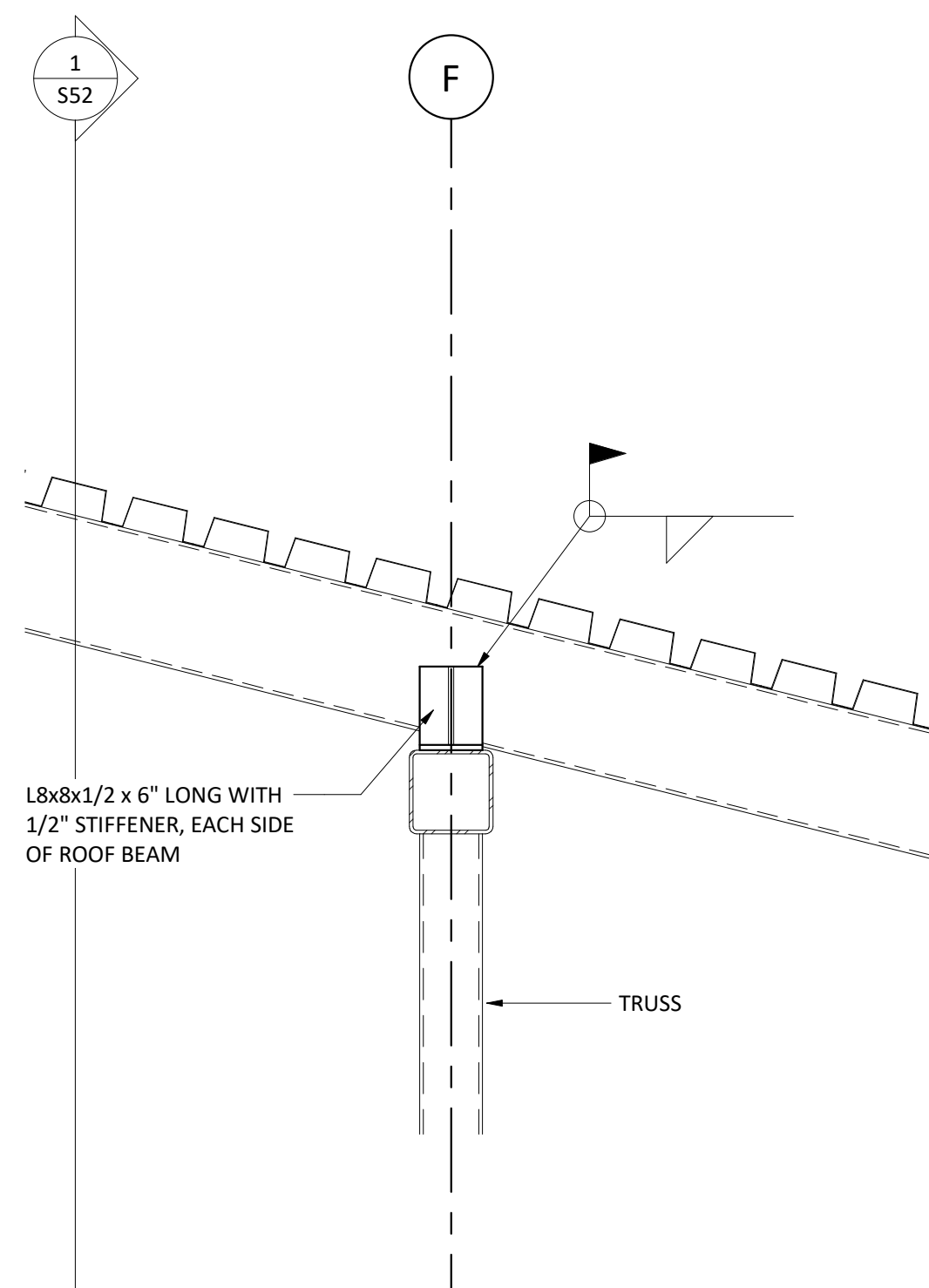

3 DETAIL - MAIN STAGE  
SCALE: 3/4" = 1'-0"

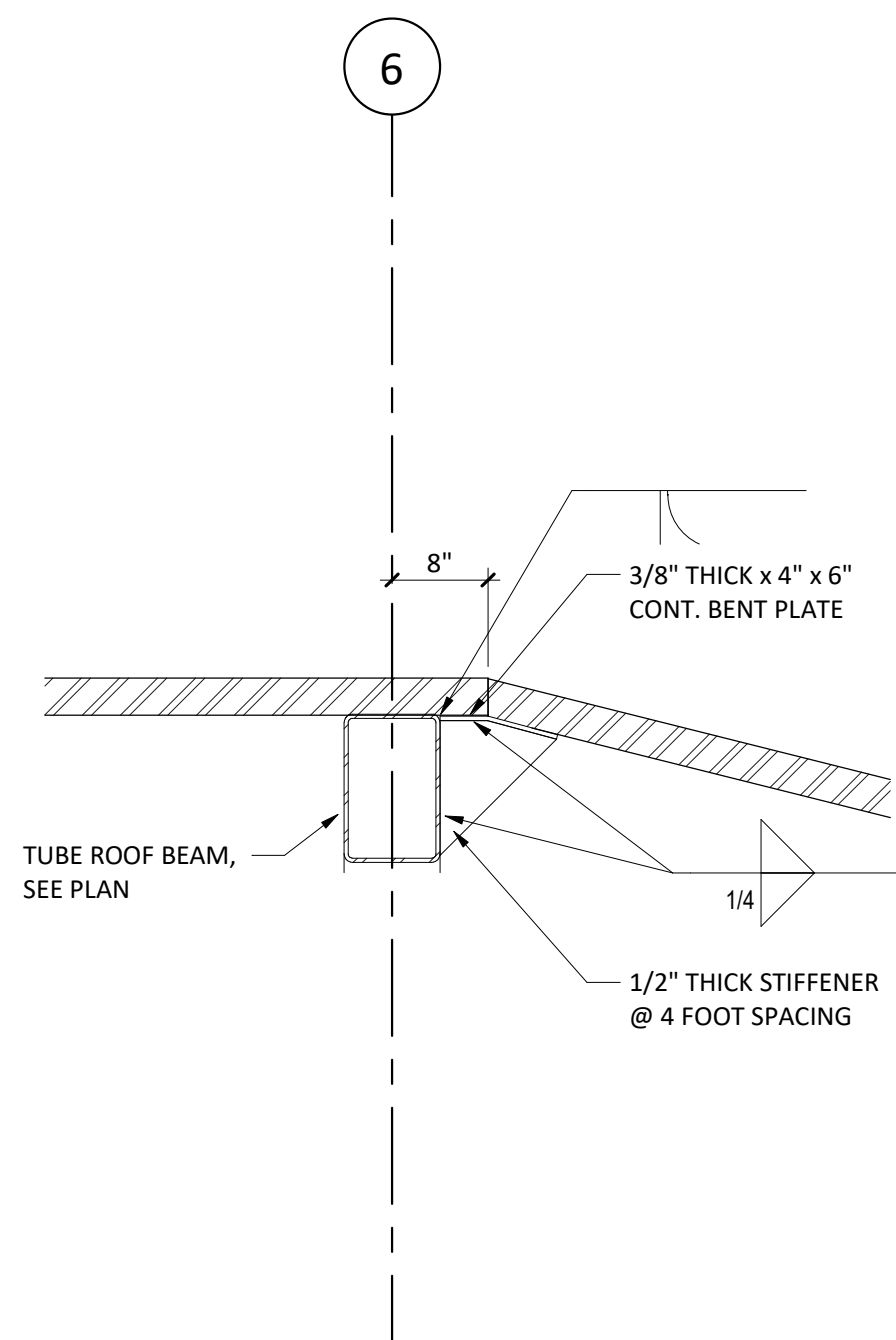

4 SECTION  
SCALE: 3/4" = 1'-0"

Certification & Seal:

PRELIMINARY  
NOT FOR CONSTRUCTION

PROJECT # AE23012 DATE: 03-31-2026  
DRAWN BY: BA CHECKED BY: BA  
OWNER:

Revision Date

ROBBINS ISLAND REGIONAL PARK AMPHITHEATER

WILLMAR, MN  
SECTIONS AND DETAILS

S52

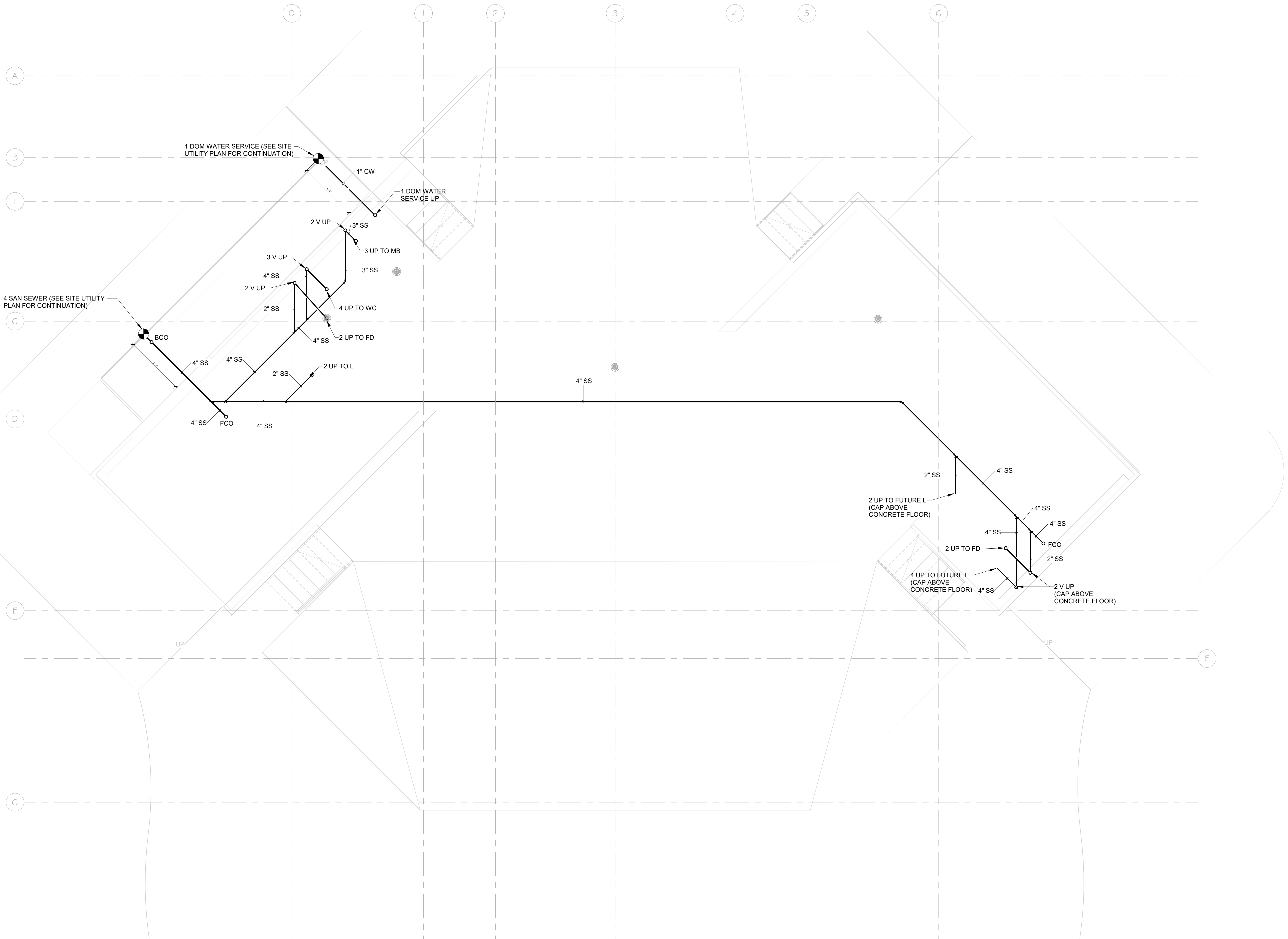

**ENGAN ASSOCIATES**  
 ARCHITECTS | INTERIOR DESIGNERS  
 shared vision. innovative design.  
 311 4th Street SW, P.O. Box 956, Willmar, MN 56201  
 320-235-0860 FAX: 320-235-0861 | www.engan.com



Certification # Seal:  
**PRELIMINARY**  
**NOT FOR CONSTRUCTION**

PROJECT # 25-132	DATE: 01/14/2026
DRAWN BY: Author	CHECKED BChecker
OWNER: ENGAN ASSOCIATES	
Revision	Date

ROBBINS ISLAND  
 AMPHITHEATER

WILLMAR, MN  
 SANITARY PLAN - UNDERFLOOR

**M100**

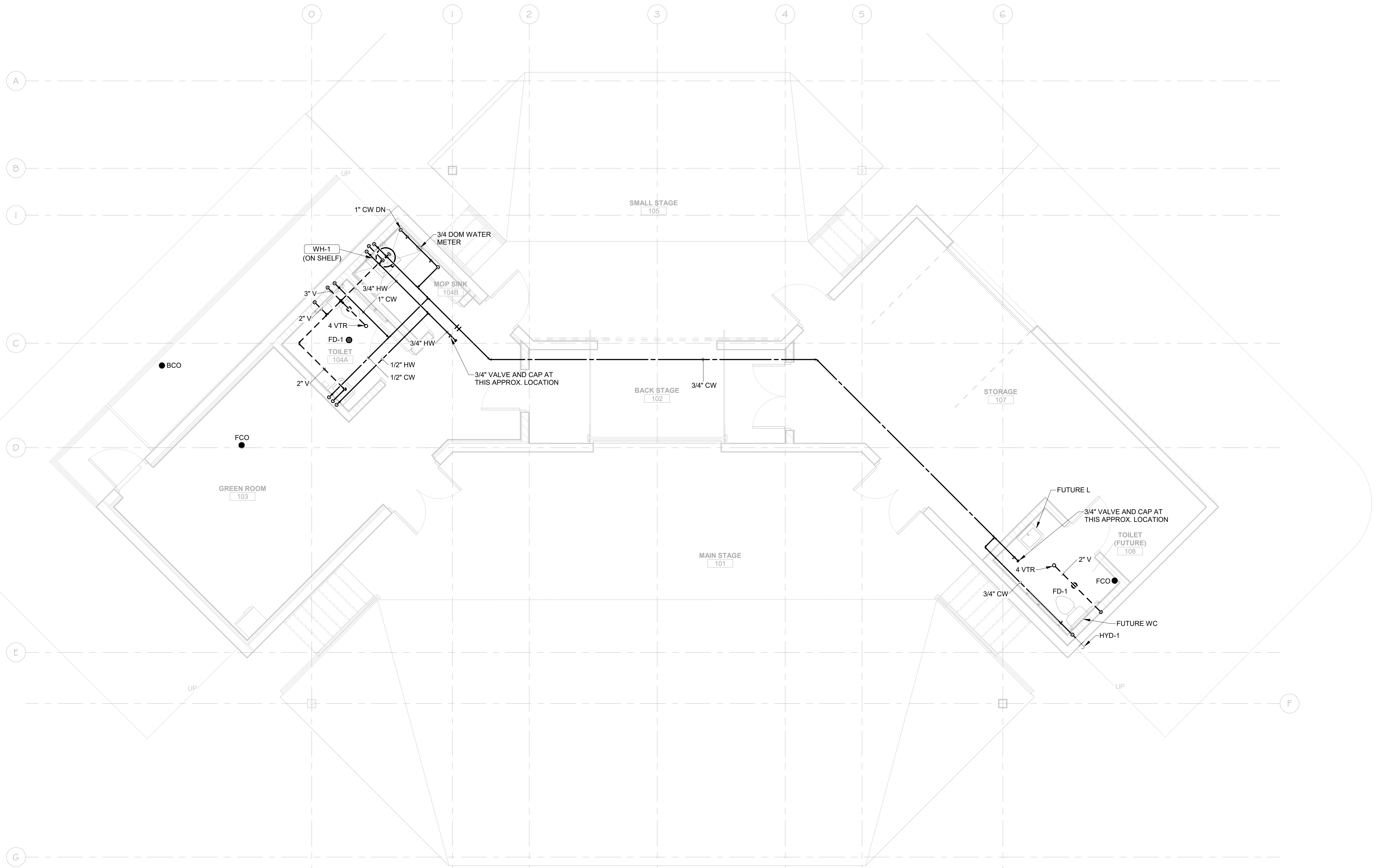

**ENGAN ASSOCIATES**  
 ARCHITECTS | INTERIOR DESIGNERS  
 shared vision. innovative design.  
 311 4th Street SW, P.O. Box 956, Willmar, MN 56201  
 320-235-0860 FAX: 320-235-0861 | www.engan.com



Certification # Seal:  
**PRELIMINARY**  
**NOT FOR CONSTRUCTION**

PROJECT # 25-132 DATE: 01/14/2026  
 DRAWN BY: Author CHECKED BChecker  
 OWNER: ENGAN ASSOCIATES

Revision	Date

ROBBINS ISLAND  
 AMPHITHEATER

WILLMAR, MN

MECHANICAL PLAN - FIRST  
 FLOOR

**M101**

3/10/2025 11:36:39 AM

1 PLUMBING - FIRST FLOOR  
 M101 1/4" = 1'-0"

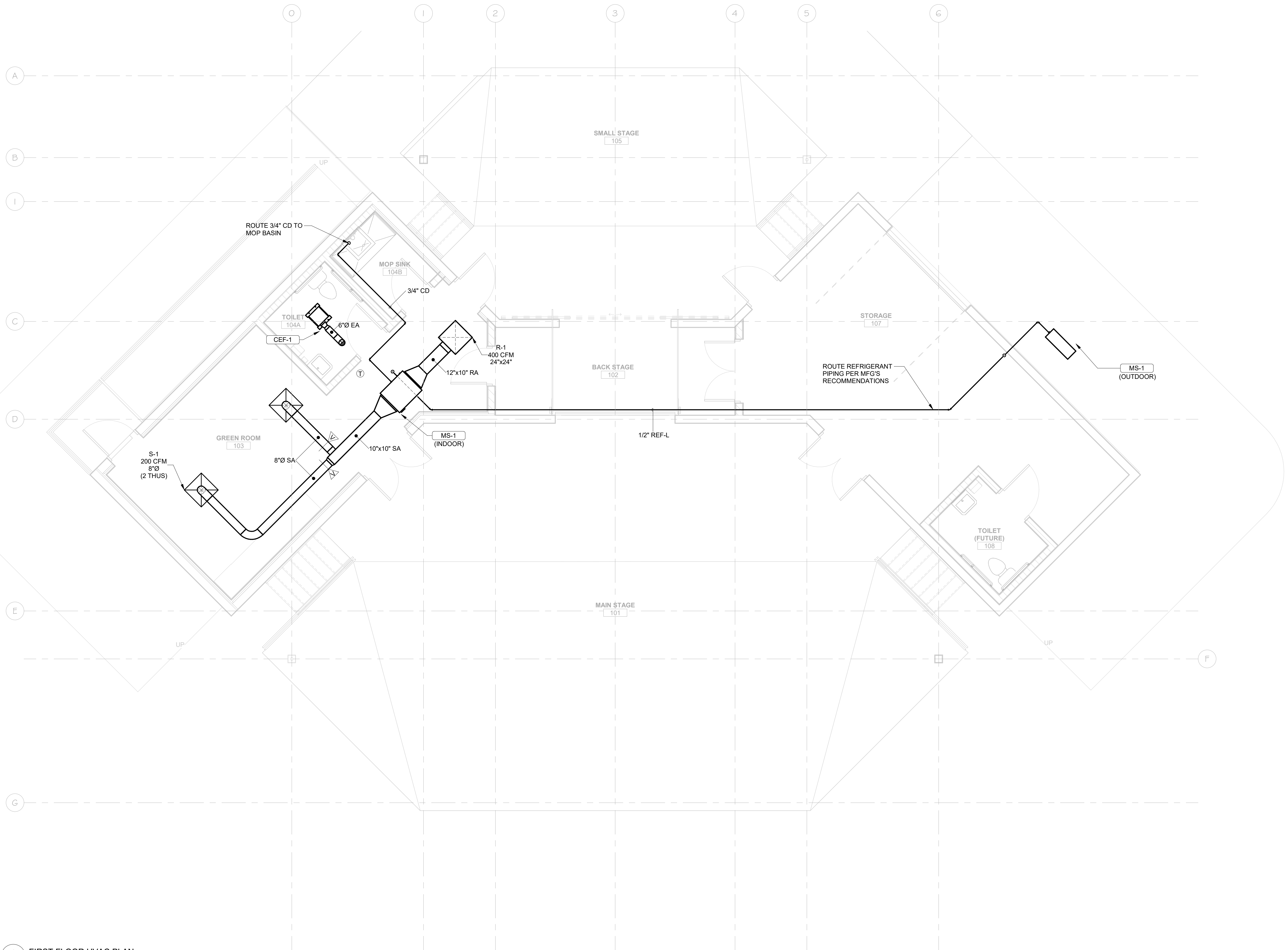

1 FIRST FLOOR HVAC PLAN  
 M300 1/4" = 1'-0"



**ENGAN ASSOCIATES**  
 ARCHITECTS | INTERIOR DESIGNERS  
 shared vision. innovative design.  
 311 4th Street SW, P.O. Box 956, Willmar, MN 56201  
 320-235-0860 FAX: 320-235-0861 | www.engan.com



**JB Electrical Design, P.C.**  
 Electrical Consulting Engineers  
 Minneapolis, MN  
 763.486.0965  
 jeff@jbelectricaldesign.com



Certification # Seal:  
**PRELIMINARY**  
**NOT FOR CONSTRUCTION**

PROJECT # 25-132	DATE: 01/14/2026
DRAWN BY: Author	CHECKED BChecker
OWNER: ENGAN ASSOCIATES	
Revision	Date

ROBBINS ISLAND  
 AMPHITHEATER

WILLMAR, MN  
 MECHANICAL HVAC PLAN -  
 FIRST FLOOR

**M300**



**ENGAN ASSOCIATES**  
 ARCHITECTS | INTERIOR DESIGNERS  
 shared vision. innovative design.  
 311 4th Street SW, P.O. Box 956, Willmar, MN 56201  
 320-235-0860 FAX: 320-235-0861 | www.engan.com

**ASCHE ENGINEERING**  
 STRUCTURAL ENGINEER  
 Alexandria, MN  
 320.808.4146 | www.AscheEngineering.com

**JB Electrical Design, P.C.**  
 Electrical Consulting Engineers  
 Minneapolis, MN  
 763.486.0965  
 jeff@jbelectricaldesign.com



Certification # Seal:  
**PRELIMINARY**  
**NOT FOR CONSTRUCTION**

PROJECT # 2025-54	DATE: -
DRAWN BY: KS/JB	CHECKED BY: JB
OWNER: CLIENT NAME	
Revision	Date

ROBBINS ISLAND  
 AMPHITHEATER

WILLMAR, MN  
 SITE PLAN ELECTRICAL

**E1-01**

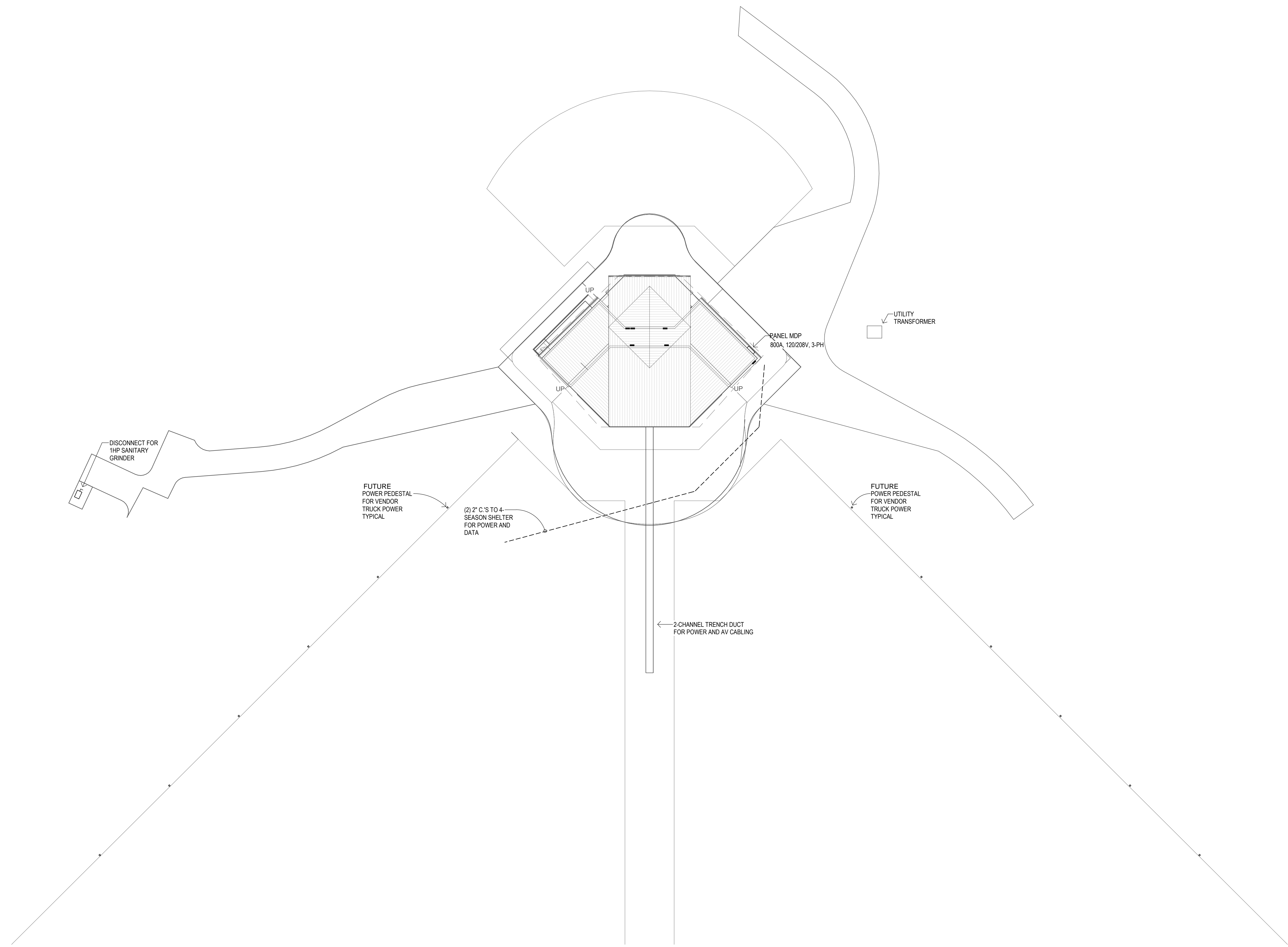

**1 SITE PLAN - ELECTRICAL**  
 1" = 20'-0"

3/27/2025 4:07:53 PM

SHEET NOTES

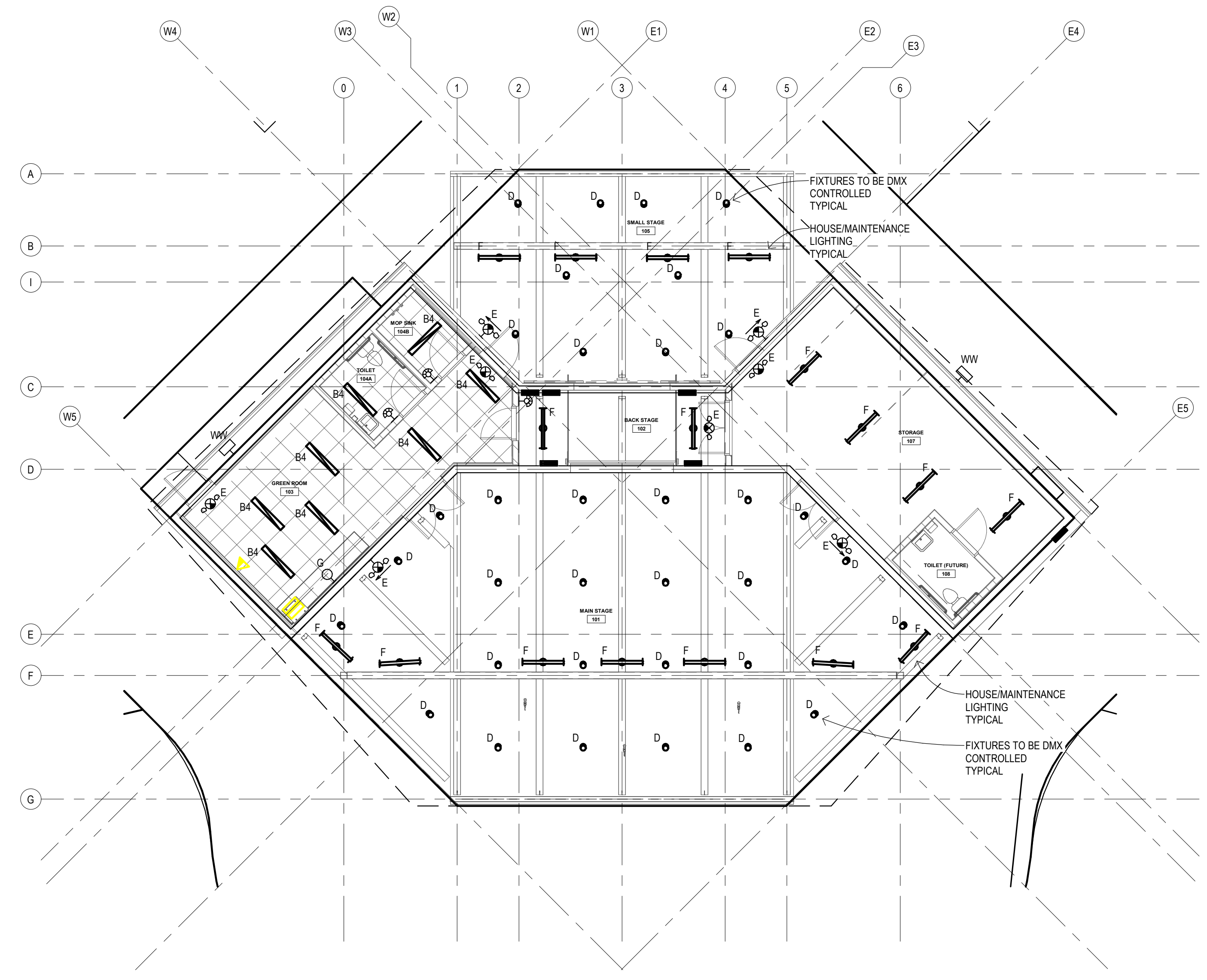

1 MAIN LEVEL LIGHTING PLAN  
1/8" = 1'-0"



**ENGAN ASSOCIATES**  
ARCHITECTS | INTERIOR DESIGNERS  
shared vision. innovative design.  
311 4th Street SW, P.O. Box 956, Willmar, MN 56201  
320-235-0860 FAX: 320-235-0861 | www.engan.com



**JB Electrical Design, P.C.**  
Electrical Consulting Engineers  
Minneapolis, MN  
763.486.0965  
jeff@jbelectricaldesign.com



Certification # Seal:  
**PRELIMINARY**  
**NOT FOR CONSTRUCTION**

PROJECT # 2025-54	DATE: -
DRAWN BY: KS/JB	CHECKED BY: JB
OWNER: CLIENT NAME	
Revision	Date

ROBBINS ISLAND  
AMPHITHEATER

WILLMAR, MN  
LIGHTING PLANS

E2-01

Certification # Seal:

**PRELIMINARY**  
**NOT FOR CONSTRUCTION**

PROJECT # 2025-54 DATE: -  
 DRAWN BY: KS/JB CHECKED BY: JB  
 OWNER: CLIENT NAME

Revision	Date

ROBBINS ISLAND AMPHITHEATER

WILLMAR, MN  
POWER PLAN

E3-01

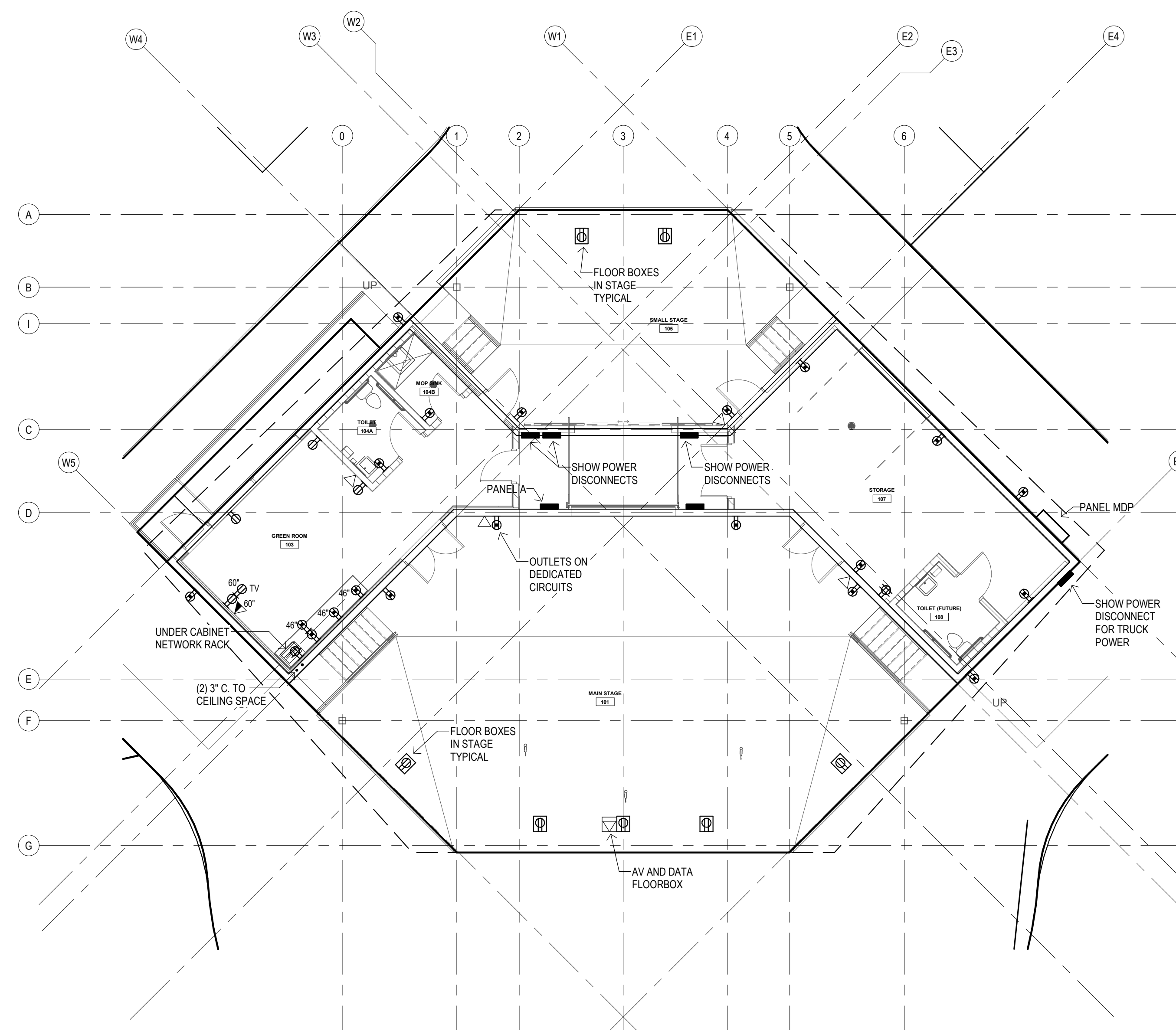

**1 FIRST FLOOR POWER PLAN**  
 1/8" = 1'-0"

Certification # Seal:

**PRELIMINARY**  
**NOT FOR CONSTRUCTION**

PROJECT # 2025-54    DATE: -  
 DRAWN BY: KS/JB    CHECKED BY: JB  
 OWNER: CLIENT NAME

Revision	Date

ROBBINS ISLAND AMPHITHEATER

WILLMAR, MN

AV PLAN

E4-01

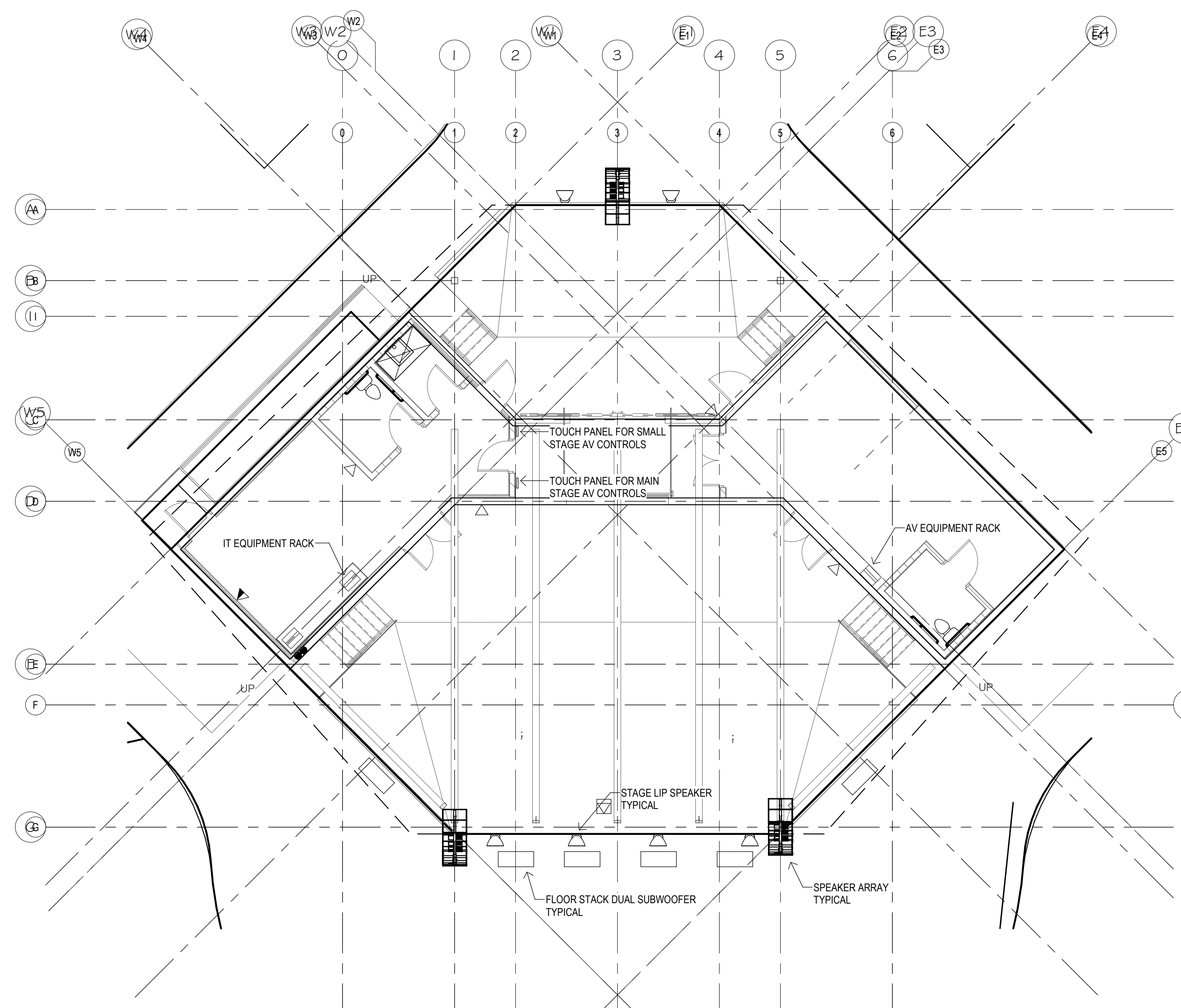

**1 FIRST FLOOR AV PLAN**  
 1/8" = 1'-0"



## ESTIMATE OF PROBABLE COST SUMMARY

PREPARED ON FEB 18, 2026 FOR:

Willmar Rotary Club  
 PO Box 294  
 Willmar, MN 56201

RE: **Robbins Island Bandshell - Willmar, MN** (845.02)

Engan Associates presents the following estimate of probable construction cost for the above-referenced project.

<b>I. Phase One - Scope of Estimate: Based Grant Estimate For Phase One</b>		
<b>ARCH</b>		
	Substructure: Soil Corrections, Concrete footings & foundation, stage, aprons, ramps & stairs.	\$1,067,206.22
<b>SITE</b>		
	Water Service	\$ 96,000.00
	Electrical Service	\$ 75,600.00
	Sanitary Service	\$ 96,000.00
	Site Path	\$ 19,360.00
	Construction Subtotal	\$ 1,354,166.22
	Non-Construction (Arch/Eng Fees 10%)	\$ 135,416.62
	Contingency (10%)	\$ 135,416.62
<b>Phase One Subtotal</b>		<b>\$ 1,624,999.46</b>

<b>II. Phase Two - Scope of estimate defined by grant estimate for phase two.</b>		
<b>ARCH</b>		
	Superstructure: All elements above stage slab	\$ 1,268,021.11
<b>SITE</b>		
	ADA Plaza Spaces	\$ 78,568.00
	Construction Subtotal	\$ 1,346,589.11

	Non-Construction (Arch/Eng Fees 10%)	\$ 134,658.91
	Contingency (10%)	\$ 134,658.91
<b>Phase Two Subtotal</b>		<b>\$ 1,615,906.93</b>

Summary of Items Included in Grant		
	Phase One	\$ 1,624,999.46
	Phase Two	\$ 1,615,906.93
<b>Total Grant Project Subtotal</b>		<b>\$ 3,240,906.39</b>

III. Items Not Included In Grant Application		
<b>ARCH</b>		
	Additional Restroom in Storage	\$ 10,000.00
	Plumbing for Future Showers	\$ 10,000.00
	Additional Windows	\$ 10,000.00
<b>SITE</b>		
	Improved East Trail	\$ 25,500.00
	ADA Seating Addition (1300 sf)	\$ 26,000.00
	Mass Grading	\$ 479,050.00
	Sound Booth Pad and Umbilical Trench (Allowance)	\$ 60,000.00
	Construction Subtotal	\$ 620,550.00
	Non-Construction (Arch/Eng Fees 10%)	\$ 62,055.00
	Contingency (10%)	\$ 62,055.00
<b>Items Not Included in Grant Subtotal</b>		<b>\$ 1,365,210.00</b>

Summary of Total Project Cost		
	<b>Total Grant Project Subtotal</b>	<b>\$ 3,240,906.39</b>
	<b>Items Not Included in Grant Subtotal</b>	<b>\$ 1,365,210.00</b>
<b>Total Project Cost</b>		<b>\$ 4,606,116.39</b>

## COST ESTIMATE NOTES

A. This estimate of probable construction cost does not include the following:

1. Costs related to financing
2. Costs related to hazardous materials (i.e., Fuel, Asbestos, Lead Paint, Etc.)
3. Moveable equipment including IT, AV, furniture, and exam equipment.

4. Phone systems of wiring in addition to the wire way
5. Computer system or wiring in addition to wire way
6. Security Camera and associated equipment
7. Site Lot Lighting
8. Building Signage

B. This estimate of probable construction cost does include:

1. Architectural and engineering costs
2. 10% Contingency

C. Comments:

1. We reserve the right to revise this cost estimate at each phase; schematic design, design development and when construction documents are complete
2. Non-construction includes architectural and engineering fees, reimbursable expenses, soil borings, surveys, and construction testing
3. If completed in phases, then an updated cost increase based upon inflation data should be included

## IN CLOSING

For any questions regarding this Project Cost Summary for The Robbins Island Bandshell please contact Andy Engan at 320.235.0893 or by email at [andy.engan@engan.com](mailto:andy.engan@engan.com). Thank you for your time and attention to this proposal, we look forward to working with you to achieve a successful outcome for your project.



**City Council Action Request**

<b>Council Meeting Date:</b>	April 6, 2026	<b>Agenda Item Number:</b>	9.D.
<b>Agenda Section:</b>	Regular Business	<b>Originating Department:</b>	Finance
<b>Resolution:</b>	Yes	<b>Prepared By:</b>	Tom Odens, Finance Director, Kyle Box, City Operations Director
<b>Ordinance:</b>	No	<b>Presented By:</b>	Jake Emeott
<b>Item:</b>	Consideration of Awarding Sale of General Obligation Tax Abatement Bonds, Series 2026A		

**RECOMMENDED ACTION:**

Motion by: \_\_\_\_\_ Second By: \_\_\_\_\_, to introduce a resolution awarding the sale of \$8,460,000 General Obligation Tax Abatement Bonds Series 2026A, fixing their form and specifications; directing their execution and delivery; and providing for their payment.

**OVERVIEW:**

The City is planning to take competitive bids on the issuance of \$8,460,000 General Obligation Tax Abatement Bonds to finance an open access fiber network in a portion of the City. Competitive bids will be received at 10:30 a.m. on Monday April 6, 2026 and presented to the City Council for its consideration that evening. Bond proceeds are expected to be wired to the City on April 23, 2026.

**BUDGETARY/FISCAL ISSUES:**

Incurring additional debt for the City of Willmar of an additional \$8,460,000.

**ALTERNATIVES TO CONSIDER:**

- a. Award sale to the successful bidder
- b. Reject all bids and rebid

**ATTACHMENTS:**

- 1. Willmar Tax Abatement 2026A AWARD RESOLUTION

EXTRACT OF MINUTES OF A MEETING OF THE  
CITY COUNCIL OF  
THE CITY OF WILLMAR, MINNESOTA

HELD: April 6, 2026

Pursuant to due call and notice thereof, a regular meeting of the City Council of the City of Willmar, Minnesota, was held in said City on the 6<sup>th</sup> day of April, 2026, commencing at 6:30 o'clock P.M.

The following members were present:

and the following were absent:

\* \* \*

\* \* \*

\* \* \*

The Mayor announced that the next order of business was consideration of the proposals which had been received for the purchase of the City's \$8,460,000 General Obligation Tax Abatement Bonds, Series 2026A.

The City Finance Director presented a tabulation of the proposals that had been received in the manner specified in the Terms of Proposal for the Bonds. The proposals were as set forth in **Exhibit A** attached.

After due consideration of the proposals, \_\_\_\_\_ introduced the following resolution, and moved its adoption:

RESOLUTION NO. \_\_\_\_\_

A RESOLUTION AWARDED THE SALE OF  
\$8,460,000 GENERAL OBLIGATION  
TAX ABATEMENT BONDS, SERIES 2026A  
FIXING THEIR FORM AND SPECIFICATIONS;  
DIRECTING THEIR EXECUTION AND DELIVERY;  
AND PROVIDING FOR THEIR PAYMENT

BE IT RESOLVED By the City Council (the “Council”) of the City of Willmar, Kandiyohi County, Minnesota (the “City”) as follows:

Section 1. Sale of Bonds.

1.01. Background; Findings. It is determined that:

(a) The City is authorized by Minnesota Statutes, Chapter 475 and Sections 469.1812 through 469.1815, as amended (collectively, the “Abatement Act”) to utilize property tax abatements on specified parcels in order to accomplish certain public purposes.

(b) On February 17, 2026, the City held a public hearing regarding, and adopted a resolution (the “Abatement Resolution”) approving, property tax abatements in the maximum amount of \$9,200,000 (the “Abatements”) on certain property in the City (the “Abatement Parcels”) pursuant to the Abatement Act to assist in financing certain public improvements including without limitation a portion of the cost of the acquisition, construction and installation of an open access, high-speed, fiber-optic, broadband infrastructure network within certain portions the City (the “Project”).

(c) It is determined that it is necessary and expedient that the City issue the Bonds to finance the Project.

(d) The City is authorized by Minnesota Statutes, Section 475.60, Subdivision 2(9) to negotiate the sale of the Bonds, if the City has retained an independent municipal advisor in connection with such sale. The City has retained Baker Tilly Municipal Advisors, LLC as an independent municipal advisor in connection with the sale of the Bonds. The actions of the City staff and the City’s municipal advisor in negotiating the sale of the Bonds are ratified and confirmed in all aspects.

(e) On January 20, 2026, the City Council adopted a resolution calling a public hearing on an Ordinance entitled “An Ordinance Authorizing the Issuance of Up To \$9,200,000 General Obligation Tax Abatement Bonds, Series 2026A and Levying of Taxes to Secure the Payment Therefor” (the “Ordinance”).

(f) A public hearing on the adoption of the Ordinance was held on February 17, 2026, and, following the public hearing the City Council adopted the Ordinance which was duly published in accordance with the City Charter. On March 2, 2026 the City Council also adopted its Resolution

Providing for the Competitive Negotiated Sale of \$9,200,000 General Obligation Tax Abatement Bonds, Series 2026A (the “Initiating Resolution”).

(g) No Certificate of Intent was filed in accordance with Section 7.04(j) of the City Charter within 15 days after adoption of the Ordinance or the Initiating Resolution.

1.02. Award to the Purchaser and Interest Rates. The proposal of \_\_\_\_\_, \_\_\_\_\_, \_\_\_\_\_ (the “Purchaser”) to purchase the Bonds of the City described in the Terms of Proposal thereof is hereby found and determined to be the most favorable offer received and is hereby accepted, and such proposal is to purchase the Bonds at a price of \$ \_\_\_\_\_ (par amount of \$8,460,000.00, plus a [net] premium of \$ \_\_\_\_\_ less an underwriter’s discount of \$ \_\_\_\_\_), for Bonds bearing interest as follows:

<u>Year of Maturity</u>	<u>Interest Rate</u>	<u>Year of Maturity</u>	<u>Interest Rate</u>
2028	%	2038	%
2029		2039	
2030		2040	
2031		2041	
2032		2042	
2033		2043	
2034		2044	
2035		2045	
2036		2046	
2037		2047	

1.03. Purchase Contract. Any amount paid by the Purchaser over the minimum purchase price shall be credited to the Debt Service Fund hereinafter created or deposited in the Construction Fund hereinafter created, as determined by the City Finance Director upon consultation with the City’s municipal advisor. The City Finance Director is directed to retain the good faith deposit of the Purchaser, pending completion of the sale of the Bonds. The Mayor and City Administrator are authorized to execute a contract with the Purchaser on behalf of the City, if requested by the Purchaser.

1.04. Terms and Principal Amounts of Bonds. The City will forthwith issue and sell the Bonds pursuant to the Act in the total principal amount of \$8,460,000, originally dated as of the date of delivery, in fully registered form and in the denominations of \$5,000 each or any integral multiple thereof, numbered No. R-1 and upward, bearing interest as above set forth, and maturing serially on February 1 in the years and amounts as follows:

<u>Year</u>	<u>Amount</u>	<u>Year</u>	<u>Amount</u>
2028	\$265,000	2038	\$425,000
2029	280,000	2039	440,000
2030	295,000	2040	460,000

2031	305,000	2041	475,000
2032	325,000	2042	495,000
2033	340,000	2043	515,000
2034	355,000	2044	540,000
2035	375,000	2045	565,000
2036	390,000	2046	590,000
2037	410,000	2047	615,000

As may be requested by the Purchaser, one or more term Bonds may be issued having mandatory sinking fund redemption and final maturity amounts conforming to the foregoing principal repayment schedule, and corresponding additions may be made to the provisions of the applicable Bond(s).

1.05. Optional Redemption. The City may elect on February 1, 2036, and on any day thereafter to prepay Bonds maturing on or after February 1, 2037. Redemption may be in whole or in part and if in part, at the option of the City and in such manner as the City will determine. If less than all Bonds of a maturity are called for redemption, the City will notify DTC (as defined in Section 7 hereof) of the particular amount of such maturity to be prepaid. DTC will determine by lot the amount of each participant's interest in such maturity to be redeemed and each participant will then select by lot the beneficial ownership interests in such maturity to be redeemed. Prepayments will be at a price of par plus accrued interest.

## Section 2. Registration and Payment.

2.01. Registered Form. The Bonds will be issued only in fully registered form. The interest thereon and, upon surrender of each Bond, the principal amount thereof, is payable by check or draft issued by the Registrar described herein.

2.02. Dates; Interest Payment Dates. Each Bond will be dated as of the last interest payment date preceding the date of authentication to which interest on the Bond has been paid or made available for payment, unless (i) the date of authentication is an interest payment date to which interest has been paid or made available for payment, in which case the Bond will be dated as of the date of authentication, or (ii) the date of authentication is prior to the first interest payment date, in which case the Bond will be dated as of the date of original issue. The interest on the Bonds is payable on February 1 and August 1 of each year, commencing February 1, 2027, to the registered owners thereof of record as of the close of business on the 15<sup>th</sup> day of the immediately preceding month, whether or not that day is a business day.

2.03. Registration. The City will appoint, and will maintain, a bond registrar, transfer agent, authenticating agent and paying agent (the "Registrar"). The effect of registration and the rights and duties of the City and the Registrar with respect thereto are as follows:

(a) Register. The Registrar will keep at its principal corporate trust office a bond register in which the Registrar provides for the registration of ownership of Bonds and the registration of transfers and exchanges of Bonds entitled to be registered, transferred or exchanged.

(b) Transfer of Bonds. Upon surrender for transfer of any Bond duly endorsed by the registered owner thereof or accompanied by a written instrument of transfer, in form satisfactory to the Registrar, duly executed by the registered owner thereof or by an attorney duly authorized by the registered owner in writing, the Registrar will authenticate and deliver, in the name of the designated transferee or transferees, one or more new Bonds of a like aggregate principal amount and maturity, as requested by the transferor. The Registrar may, however, close the books for registration of any transfer after the 15th day of the month preceding each interest payment date and until that interest payment date.

(c) Exchange of Bonds. When any Bonds are surrendered by the registered owner for exchange the Registrar will authenticate and deliver one or more new Bonds of a like aggregate principal amount and maturity as requested by the registered owner or the owner's attorney in writing.

(d) Cancellation. All Bonds surrendered upon any transfer or exchange will be promptly cancelled by the Registrar and thereafter disposed of as directed by the City.

(e) Improper or Unauthorized Transfer. When a Bond is presented to the Registrar for transfer, the Registrar may refuse to transfer the Bond until the Registrar is satisfied that the endorsement on the Bond or separate instrument of transfer is valid and genuine and that the requested transfer is legally authorized. The Registrar will incur no liability for the refusal, in good faith, to make transfers which it, in its judgment, deems improper or unauthorized.

(f) Persons Deemed Owners. The City and the Registrar may treat the person in whose name a Bond is at any time registered, as of the applicable record date, in the bond register as the absolute owner of such Bond, whether the Bond is overdue or not, for the purpose of receiving payment of, or on account of, the principal of and interest on the Bond and for all other purposes and payments so made to a registered owner or upon the owner's order will be valid and effectual to satisfy and discharge the liability upon the Bond to the extent of the sum or sums so paid.

(g) Taxes, Fees and Charges. The Registrar may impose a charge upon the owner thereof for a transfer or exchange of Bonds, sufficient to reimburse the Registrar for any tax, fee or other governmental charge required to be paid with respect to the transfer or exchange.

(h) Mutilated, Lost, Stolen or Destroyed Bonds. If a Bond becomes mutilated or is destroyed, stolen or lost, the Registrar will deliver a new Bond of like amount, number, maturity date and tenor in exchange and substitution for and upon cancellation of the mutilated Bond or in lieu of and in substitution for any Bond destroyed, stolen or lost, upon the payment of the reasonable expenses and charges of the Registrar in connection therewith; and, in the case of a Bond destroyed, stolen or lost, upon filing with the Registrar of evidence satisfactory to the Registrar that the Bond was destroyed, stolen or lost, and of the ownership thereof, and upon furnishing to the Registrar an appropriate bond or indemnity in form, substance and amount satisfactory to the Registrar and as provided by law, in which both the City and the Registrar must be named as obligees. Bonds so

surrendered to the Registrar will be cancelled by the Registrar and evidence of such cancellation must be given to the City. If the mutilated, destroyed, stolen or lost Bond has already matured or been called for redemption in accordance with its terms it is not necessary to issue a new Bond prior to payment.

(i) Redemption. In the event any of the Bonds are called for redemption, written notice thereof identifying the Bonds to be redeemed will be given by the Registrar by mailing a copy of the redemption notice by first class mail (postage prepaid) at least 30 days prior to the redemption date to the registered owner of each Bond to be redeemed at the address shown on the registration books kept by the Registrar and by publishing the notice if required by law. Failure to give notice by publication or by mail to any registered owner, or any defect therein, will not affect the validity of the proceedings for the redemption of Bonds. Bonds so called for redemption will cease to bear interest after the specified redemption date, provided that the funds for the redemption are on deposit with the place of payment at that time.

2.04. Appointment of Initial Registrar. The City appoints U.S. Bank Trust Company, National Association, St. Paul, Minnesota, as the initial Registrar. The Mayor and the City Clerk are authorized to execute and deliver, on behalf of the City, a contract with the Registrar. Upon merger or consolidation of the Registrar with another corporation, if the resulting corporation is a bank or trust company authorized by law to conduct such business, the resulting corporation is authorized to act as successor Registrar. The City agrees to pay the reasonable and customary charges of the Registrar for the services performed. The City reserves the right to remove the Registrar upon 30 days' notice and upon the appointment of a successor Registrar, in which event the predecessor Registrar must deliver all cash and Bonds in its possession to the successor Registrar and deliver the bond register to the successor Registrar. On or before each principal or interest due date, without further order of this Council, the City Clerk must transmit to the Registrar money sufficient for the payment of all principal and interest then due.

2.05. Execution, Authentication and Delivery. The Bonds will be prepared under the direction of the City Finance Director and executed on behalf of the City by the signatures of the Mayor and the City Clerk, provided that all signatures may be printed, engraved or lithographed facsimiles of the originals. If an officer whose signature or a facsimile of whose signature appears on the Bonds ceases to be such officer before the delivery of any Bond, that signature or facsimile will nevertheless be valid and sufficient for all purposes, the same as if the officer had remained in office until delivery. Notwithstanding such execution, a Bond will not be valid or obligatory for any purpose or entitled to any security or benefit under this Resolution unless and until a certificate of authentication on the Bond has been duly executed by the manual signature of an authorized representative of the Registrar. Certificates of authentication on different Bonds need not be signed by the same representative. The executed certificate of authentication on a Bond is conclusive evidence that it has been authenticated and delivered under this Resolution. When the Bonds have been so prepared, executed and authenticated, the City Finance Director will deliver the same to the Purchaser thereof upon payment of the purchase price in accordance with the contract of sale heretofore made and executed, and the Purchaser is not obligated to see to the application of the purchase price.

Section 3. Form of Bond.

3.01. Form of Bonds. The Bonds will be printed or typewritten in substantially the form set forth in **Exhibit B** attached hereto.

3.02 Approving Legal Opinion. The City Finance Director is authorized and directed to obtain a copy of the proposed approving legal opinion of Kutak Rock LLP, Minneapolis, Minnesota, which will be complete except as to dating thereof and to cause the opinion to be printed on or accompany each Bond.

Section 4. Payment; Security; Pledges and Covenants.

4.01 Debt Service Fund. The Bonds are payable from the General Obligation Tax Abatement Bonds, Series 2026A Debt Service Fund (the “Debt Service Fund”) hereby created. The Debt Service Fund shall be administered and maintained by the Finance Director as a bookkeeping account separate and apart from all other funds maintained in the official financial records of the City. Amounts in the Debt Service Fund are irrevocably pledged to the Bonds. To the Debt Service Fund hereby created, there is hereby pledged and irrevocably appropriated and there will be credited: (A) the proceeds of general ad valorem property taxes herein or hereafter levied and the Abatements; (B) capitalized interest financed from Bond proceeds, if any; (C) the amount over the minimum purchase price paid by the Purchaser, to the extent designated for deposit in the Debt Service Fund in accordance with Section 1.03 hereof; and (D) all investment earnings on funds in the Debt Service Fund; and (E) any and all other moneys which are properly available and are appropriated by the City Council to the Debt Service Fund. If a payment of principal or interest on the Bonds becomes due when there is not sufficient money in the Debt Service Fund to pay the same, the City Finance Director is directed to pay such principal or interest from other funds of the City, and such fund will be reimbursed for those advances out of the proceeds of Abatements and Taxes when collected.

4.02 Construction Fund. The proceeds of the Bonds, less the appropriations made in Section 4.01, together with any other funds appropriated for the Project will be deposited in a separate construction fund (the “Construction Fund”) to be used solely to defray expenses of the Project and the payment of principal and interest on the Bonds prior to the completion and payment of all costs of the Project. Any balance remaining in the Construction Fund after completion of the Project and the costs thereof paid, may be used as provided in Minnesota Statutes, Section 475.65. Thereafter, the Construction Fund is to be closed and any remaining balances therein and subsequent collections of taxes for the Project are to be deposited in the Debt Service Fund.

4.03. Pledge of Tax Levy. For the purpose of paying the principal of and interest on the Bonds, there is hereby levied a direct annual irrevocable ad valorem property tax (the “Taxes”) upon all of the taxable property in the City, which will be spread upon the tax rolls and collected with and as part of other general taxes of the City. The taxes will be credited to the Debt Service Fund above provided and will be in the years (being each year of collection) and amounts as set forth in **Exhibit C**.

It is hereby determined that the estimated collections of Abatements and the foregoing Taxes will produce at least 5% in excess of the amount needed to meet when due the principal and interest payments on the Bonds.

4.04. Certification to County Auditor as to Debt Service Fund Amount. It is hereby determined that the estimated collections of Abatements and the foregoing Taxes will produce at least 5% in excess of the amount needed to meet when due the principal and interest payments on the Bonds. The amount of the Abatements is at least equal to the principal amount of the Bonds. The tax levy herein provided is irrevocable until all of the Bonds are paid, provided that at the time the City makes its annual tax levies the City Finance Director may certify to the County Auditor/Treasurer of Kandiyohi County, Minnesota (the "County Auditor") the amount available in the Debt Service Fund to pay principal and interest due during the ensuing year, and the County Auditor will thereupon reduce the levy collectible during such year by the amount so certified in the manner and to the extent permitted by Section 475.61, subdivision 3 of the Act.

4.05. Registration of Resolution. The City Finance Director is authorized and directed to file a certified copy of this resolution with the County Auditor of Kandiyohi County and to obtain the certificate required by Minnesota Statutes, Section 475.63.

4.06 General Obligation Pledge. For the prompt and full payment of the principal of and interest on the Bonds, as the same respectively become due, the full faith, credit and taxing powers of the City will be and are hereby irrevocably pledged. If the balance in the Debt Service Fund is ever insufficient to pay all principal and interest then due on the Bonds and any other bonds payable therefrom, the deficiency will be promptly paid out of monies in the general fund of the City which are available for such purpose, and such general fund may be reimbursed with or without interest from the Debt Service Fund when a sufficient balance is available therein.

Section 5. Authentication of Transcript.

5.01. City Proceedings and Records. The officers of the City are authorized and directed to prepare and furnish to the Purchaser and to the attorneys approving the Bonds, certified copies of proceedings and records of the City relating to the Bonds and to the financial condition and affairs of the City, and such other certificates, affidavits and transcripts as may be required to show the facts within their knowledge or as shown by the books and records in their custody and under their control, relating to the validity and marketability of the Bonds, and such instruments, including any heretofore furnished, may be deemed representations of the City as to the facts stated therein.

5.02. Certification as to Official Statement. The Mayor, City Administrator, City Clerk and City Finance Director, or any of them, are authorized and directed to certify that they have examined the Official Statement prepared and circulated in connection with the issuance and sale of the Bonds and that to the best of their knowledge and belief the Official Statement, as of the date thereof, is a complete and accurate representation of the facts and representations made therein as of the date of the Official Statement, as it relates to the City and the Bonds.

5.03. Other Certificates. The Mayor, City Administrator, City Clerk and City Finance Director, or any of them, are hereby authorized and directed to furnish to the Purchaser at the closing such certificates as are required as a condition of sale. Unless litigation shall have been commenced and be pending questioning the Bonds or the organization of the City or incumbency of its officers, at the closing the Mayor, City Administrator, City Clerk and City Finance Director, or any of them, shall also execute and deliver to the Purchaser a suitable certificate as to absence of material litigation, and the Finance Director shall also execute and deliver a certificate as to payment for and delivery of the Bonds.

5.04 Electronic Signatures. The electronic signature of the Mayor, City Administrator, City Clerk, and Finance Director to this resolution and to any certificate authorized to be executed hereunder shall be as valid as an original signature of such party and shall be effective to bind the City thereto. For purposes hereof, (i) “electronic signature” means (a) a manually signed original signature that is then transmitted by electronic means or (b) a signature obtained through DocuSign or Adobe or a similarly digitally auditable signature gathering process; and (ii) “transmitted by electronic means” means sent in the form of a facsimile or sent via the internet as a portable document format (“pdf”) or other replicating image attached to an electronic mail or internet message.

Section 6. Tax Covenants.

6.01. Tax-Exempt Bonds. The City covenants and agrees with the holders from time to time of the Bonds that it will not take or permit to be taken by any of its officers, employees or agents any action which would cause the interest on the Bonds to become subject to taxation under the Internal Revenue Code of 1986, as amended (the Code), and the Treasury Regulations promulgated thereunder, in effect at the time of such actions, and that it will take or cause its officers, employees or agents to take, all affirmative action within its power that may be necessary to ensure that such interest will not become subject to taxation under the Code and applicable Treasury Regulations, as presently existing or as hereafter amended and made applicable to the Bonds. The City will comply with all requirements necessary under the Code to establish and maintain the exclusion from gross income of the interest on the Bonds under Section 103 of the Code, including without limitation requirements relating to temporary periods for investments and limitations on amounts invested at a yield greater than the yield on the Bonds.

6.02 Rebate. The City shall comply with requirements necessary under the Code to establish and maintain the exclusion from gross income of the interest on the Bonds under Section 103 of the Code, including without limitation (1) requirements relating to temporary periods for investments, (2) limitations on amounts invested at a yield greater than the yield on the Bonds, and (3) the rebate of excess investment earnings to the United States unless the Bonds qualify for an exception to the rebate requirement under the Code and related Treasury Regulations.

6.03. Not Private Activity Bonds. The City further covenants not to use the proceeds of the Bonds or the Project financed by the Bonds, or to cause or permit them or any of them to be used, in such a manner as to cause the Bonds to be “private activity bonds” within the meaning of Sections 103 and 141 through 150 of the Code.

6.04. No Designation of Qualified Tax -Exempt Obligations. The Bonds have not been designated as a “qualified tax-exempt obligations” within the meaning of Section 265(b)(3) of the Code.

6.05. Procedural Requirements. The City will use its best efforts to comply with any federal procedural requirements which may apply in order to effectuate the designations made by this section.

Section 7. Book-Entry System; Limited Obligation of City.

7.01. DTC. The Bonds will be initially issued in the form of a separate single typewritten or printed fully registered Bond for each of the maturities set forth in Section 1.04 hereof. Upon initial issuance, the ownership of each Bond will be registered in the registration books kept by the Registrar in the name of Cede & Co., as nominee for The Depository Trust Company, New York, New York, and its successors and assigns (“DTC”). Except as provided in this section, all of the outstanding Bonds will be registered in the registration books kept by the Registrar in the name of Cede & Co., as nominee of DTC.

7.02. Participants. With respect to Bonds registered in the registration books kept by the Registrar in the name of Cede & Co., as nominee of DTC, the City, the Registrar and the Paying Agent will have no responsibility or obligation to any broker dealers, banks and other financial institutions from time to time for which DTC holds Bonds as securities depository (the “Participants”) or to any other person on behalf of which a Participant holds an interest in the Bonds, including but not limited to any responsibility or obligation with respect to (i) the accuracy of the records of DTC, Cede & Co. or any Participant with respect to any ownership interest in the Bonds, (ii) the delivery to any Participant or any other person (other than a registered owner of Bonds, as shown by the registration books kept by the Registrar) of any notice with respect to the Bonds, including any notice of redemption, or (iii) the payment to any Participant or any other person, other than a registered owner of Bonds, of any amount with respect to principal of, premium, if any, or interest on the Bonds. The City, the Registrar and the Paying Agent may treat and consider the person in whose name each Bond is registered in the registration books kept by the Registrar as the holder and absolute owner of such Bond for the purpose of payment of principal, premium and interest with respect to such Bond, for the purpose of registering transfers with respect to such Bond, and for all other purposes. The Paying Agent will pay all principal of, premium, if any, and interest on the Bonds only to or on the order of the respective registered owners, as shown in the registration books kept by the Registrar, and all such payments will be valid and effectual to fully satisfy and discharge the City’s obligations with respect to payment of principal of, premium, if any, or interest on the Bonds to the extent of the sum or sums so paid. No person other than a registered owner of Bonds, as shown in the registration books kept by the Registrar, will receive a certificated Bond evidencing the obligation of this resolution. Upon delivery by DTC to the City Finance Director of a written notice to the effect that DTC has determined to substitute a new nominee in place of Cede & Co., the words “Cede & Co.,” will refer to such new nominee of DTC; and upon receipt of such a notice, the City Finance Director will promptly deliver a copy of the same to the Registrar and Paying Agent.

7.03. Representation Letter. The City has heretofore executed and delivered to DTC a Blanket Issuer Letter of Representations (the “Representation Letter”) which will govern payment

of principal of, premium, if any, and interest on the Bonds and notices with respect to the Bonds. Any Paying Agent or Registrar subsequently appointed by the City with respect to the Bonds will agree to take all action necessary for all representations of the City in the Representation Letter with respect to the Registrar and Paying Agent, respectively, to be complied with at all times.

7.04. Transfers Outside Book-Entry System. In the event the City, by resolution of the City Council, determines that it is in the best interests of the persons having beneficial interests in the Bonds that they be able to obtain Bond certificates, the City will notify DTC, whereupon DTC will notify the Participants, of the availability through DTC of Bond certificates. In such event the City will issue, transfer and exchange Bond certificates as requested by DTC and any other registered owners in accordance with the provisions of this Resolution. DTC may determine to discontinue providing its services with respect to the Bonds at any time by giving notice to the City and discharging its responsibilities with respect thereto under applicable law. In such event, if no successor securities depository is appointed, the City will issue and the Registrar will authenticate Bond certificates in accordance with this resolution and the provisions hereof will apply to the transfer, exchange and method of payment thereof.

7.05. Payments to Cede & Co. Notwithstanding any other provision of this Resolution to the contrary, so long as a Bond is registered in the name of Cede & Co., as nominee of DTC, payments with respect to principal of, premium, if any, and interest on the Bond and all notices with respect to the Bond will be made and given, respectively in the manner provided in DTC's Operational Arrangements, as set forth in the Representation Letter.

#### Section 8. Continuing Disclosure.

8.01. City Compliance with Provisions of Continuing Disclosure Certificate. The City hereby covenants and agrees that it will comply with and carry out all of the provisions of the Continuing Disclosure Certificate. Notwithstanding any other provision of this Resolution, failure of the City to comply with the Continuing Disclosure Certificate is not an event of default with respect to the Bonds; however any Bondholder may take such actions as may be necessary and appropriate, including seeking mandate or specific performance by court order, to cause the City to comply with its obligations under this section.

8.02. Execution of Continuing Disclosure Certificate. "Continuing Disclosure Certificate" means that certain Continuing Disclosure Certificate executed by the Mayor and City Clerk and dated the date of issuance and delivery of the Bonds, as originally executed and as it may be amended from time to time in accordance with the terms thereof.

Section 9. Defeasance. When the Bonds and all accrued interest thereon, have been discharged as provided in this section, all pledges, covenants and other rights granted by this resolution to the holders of the Bonds will cease, except that the pledge of the full faith and credit of the City for the prompt and full payment of the principal of and interest on the Bonds will remain in full force and effect. The City may discharge the Bonds which are due on any date by depositing with the Registrar on or before that date a sum sufficient for the payment thereof in full or by depositing irrevocably in escrow, with a suitable institution qualified by law as an escrow agent for this purpose, cash or securities which are backed by the full faith and credit of the United States of America, or any other security authorized under Minnesota law for such purpose, bearing interest payable at such times

and at such rates and maturing on such dates and in such amounts as shall be required and sufficient, subject to sale and/or reinvestment in like securities, to pay said obligation(s), which may include any interest payment on such Bond and/or principal amount due thereon at a stated maturity (or if irrevocable provision shall have been made for permitted prior redemption of such principal amount, at such earlier redemption date). If any Bond should not be paid when due, it may nevertheless be discharged by depositing with the Registrar a sum sufficient for the payment thereof in full with interest accrued to the date of such deposit.

Passed and adopted this 6th day of April, 2026.

---

Mayor

Attest:

---

City Clerk

The motion for adoption of the foregoing resolution was duly seconded by Member \_\_\_\_\_, and upon vote being taken thereon, the following voted in favor thereof:

and the following voted against the same:

whereupon said resolution was declared duly passed and adopted.

**EXHIBIT A**  
**PROPOSALS**

**EXHIBIT B**

**FORM OF BOND**

No. R- \_\_\_\_\_

\$ \_\_\_\_\_

UNITED STATES OF AMERICA  
STATE OF MINNESOTA  
COUNTY OF KANDIYOHI  
CITY OF WILLMAR

**GENERAL OBLIGATION TAX ABATEMENT BOND, SERIES 2026A**

<u>Rate</u>	<u>Maturity</u>	<u>Date of Original Issue</u>	<u>CUSIP</u>
	February 1, 20__	_____, 2026	

Registered Owner: Cede & Co.

The City of Willmar Minnesota, a duly organized and existing municipal corporation in Kandiyohi County, Minnesota (the “City”), acknowledges itself to be indebted and for value received hereby promises to pay to the Registered Owner specified above or registered assigns, the principal sum set forth above on the Maturity Date specified above, unless called for earlier redemption, with interest thereon from the date hereof at the annual Rate specified above (calculated on the basis of a 360-day year of twelve 30 day months), payable February 1 and August 1 in each year, commencing February 1, 2027, to the person in whose name this Bond is registered at the close of business on the 15<sup>th</sup> day (whether or not a business day) of the immediately preceding month. The interest hereon and, upon presentation and surrender hereof, the principal hereof are payable in lawful money of the United States of America by check or draft by U.S. Bank Trust Company, National Association, St. Paul, Minnesota, as Registrar, Authenticating Agent, Transfer Agent and Paying Agent, or its designated successor under the Resolution described herein. For the prompt and full payment of such principal and interest as the same respectively become due, the full faith and credit and taxing powers of the City have been and are hereby irrevocably pledged.

The City may elect on February 1, 2036, and on any date thereafter to prepay Bonds due on or after February 1, 2037. Redemption may be in whole or in part and if in part, at the option of the City and in such manner as the City will determine. If less than all Bonds of a maturity are called for redemption, the City will notify the Depository Trust Company (“DTC”) of the particular amount of such maturity to be prepaid. DTC will determine by lot the amount of each participant’s interest in such maturity to be redeemed and each participant will then select by lot the beneficial ownership interests in such maturity to be redeemed. Prepayments will be at a price of par plus accrued interest.

The City Council has not designated the issue of Bonds of which this Bond forms a part as “qualified tax exempt obligations” within the meaning of Section 265(b)(3) of the Internal

Revenue Code of 1986, as amended (the “Code”) relating to disallowance of interest expense for financial institutions.

This Bond is one of an issue in the aggregate principal amount of \$8,460,000 all of like original issue date and tenor, except as to number, maturity date, denomination, redemption privilege and interest rate, all issued pursuant to a resolution adopted by the City Council on April 6, 2026 (the “Resolution”), for the purpose of providing money to assist in financing certain public improvements including without limitation a portion of the cost of the acquisition, construction and installation of an open access, high-speed, fiber-optic, broadband infrastructure network within certain portions the City, pursuant to and in full conformity with the Constitution and laws of the State of Minnesota, including Minnesota Statutes, Chapters 469 and 475, as amended. The principal hereof and interest hereon are payable from property tax abatements and from ad valorem taxes levied on all taxable property in the City, all as set forth in the Resolution to which reference is made for a full statement of rights and powers thereby conferred. The full faith and credit of the City are irrevocably pledged for payment of this Bond and the City Council has obligated itself to levy additional ad valorem taxes on all taxable property, in the City in the event of any deficiency in property tax abatements, and ad valorem taxes pledged, which taxes may be levied without limitation as to rate or amount. The Bonds of this series are issued only as fully registered Bonds in denominations of \$5,000 or any integral multiple thereof of single maturities.

As provided in the Resolution and subject to certain limitations set forth therein, this Bond is transferable upon the books of the City at the principal office of the Registrar, by the registered owner hereof in person or by the owner’s attorney duly authorized in writing, upon surrender hereof together with a written instrument of transfer satisfactory to the Registrar, duly executed by the registered owner or the owner’s attorney; and may also be surrendered in exchange for Bonds of other authorized denominations. Upon such transfer or exchange the City will cause a new Bond or Bonds to be issued in the name of the transferee or registered owner, of the same aggregate principal amount, bearing interest at the same rate and maturing on the same date, subject to reimbursement for any tax, fee or governmental charge required to be paid with respect to such transfer or exchange.

The City and the Registrar may deem and treat the person in whose name this Bond is registered as the absolute owner hereof, whether this Bond is overdue or not, for the purpose of receiving payment and for all other purposes, and neither the City nor the Registrar will be affected by any notice to the contrary.

IT IS HEREBY CERTIFIED, RECITED, COVENANTED AND AGREED that all acts, conditions and things required by the Constitution, laws of the State of Minnesota and charter of the City, to be done, to exist, to happen and to be performed preliminary to and in the issuance of this Bond in order to make it a valid and binding general obligation of the City in accordance with its terms, have been done, do exist, have happened and have been performed as so required, and that the issuance of this Bond does not cause the indebtedness of the City to exceed any constitutional, statutory or charter limitation of indebtedness.

This Bond is not valid or obligatory for any purpose or entitled to any security or benefit under the Resolution until the Certificate of Authentication hereon has been executed by the Registrar by manual signature of one of its authorized representatives.

IN WITNESS WHEREOF, the City of Willmar, Kandiyohi County, Minnesota, by its City Council, has caused this Bond to be executed on its behalf by the facsimile or manual signatures of the Mayor and City Clerk and has caused this Bond to be dated as of the date set forth below.

Dated: \_\_\_\_\_, 2026

CITY OF WILLMAR  
KANDIYOHI COUNTY, MINNESOTA

\_\_\_\_\_  
Mayor

ATTEST:

\_\_\_\_\_  
City Clerk

CERTIFICATE OF AUTHENTICATION

This is one of the Bonds delivered pursuant to the Resolution mentioned within.

**U.S. BANK TRUST COMPANY,  
NATIONAL ASSOCIATION**

By \_\_\_\_\_  
Authorized Representative

---

The following abbreviations, when used in the inscription on the face of this Bond, will be construed as though they were written out in full according to applicable laws or regulations:

TEN COM -- as tenants  
in common

TEN ENT -- as tenants  
by entirety

JT TEN -- as joint tenants  
with right of  
survivorship and  
not as tenants in  
common

UNIF GIFT MIN ACT  
\_\_\_\_ Custodian \_\_\_\_  
(Cust) (Minor)  
under Uniform Gift or Transfer to  
Minors Act  
of.....  
(State)

Additional abbreviations may also be used though not in the above list.

---

### ASSIGNMENT

For value received, the undersigned hereby sells, assigns and transfers unto \_\_\_\_\_ the within Bond and all rights thereunder, and does hereby irrevocably constitute and appoint \_\_\_\_\_ attorney to transfer the said Bond on the books kept for registration of the within Bond, with full power of substitution in the premises.

Dated: \_\_\_\_\_

Notice: The assignor's signature to this assignment must correspond with the name as it appears upon the face of the within Bond in every particular, without alteration or any change whatever.

Signature Guaranteed:

\_\_\_\_\_

NOTICE: Signature(s) must be guaranteed by a financial institution that is a member of the Securities Transfer Agent Medallion Program ("STAMP"), the Stock Exchange Medallion Program ("SEMP"), the New York Stock Exchange, Inc. Medallion Signatures Program ("MSP") or other such "signature guarantee program" as may be determined by the Registrar in addition to,

or in substitution for, STAMP, SEMP or MSP, all in accordance with the Securities Exchange Act of 1934, as amended.

The Registrar will not effect transfer of this Bond unless the information concerning the assignee requested below is provided.

Name and Address: \_\_\_\_\_  
\_\_\_\_\_

\_\_\_\_\_  
(Include information for all joint owners if this Bond is held by joint account.)

Please insert social security or other identifying number of assignee

\_\_\_\_\_

#### PROVISIONS AS TO REGISTRATION

The ownership of the principal of and interest on the within Bond has been registered on the books of the Registrar in the name of the person last noted below.

Date of Registration

\_\_\_\_\_, 2026

Registered Owner

Cede & Co.

Federal ID #13-2555119

Signature of Registrar

\_\_\_\_\_

**EXHIBIT C**

**Tax Levy**

STATE OF MINNESOTA  
COUNTY OF KANDIYOHI

COUNTY AUDITOR/TREASURER'S  
CERTIFICATE AS TO TAX  
LEVY AND REGISTRATION

I, the undersigned County Auditor/Treasurer of Kandiyohi County, Minnesota, hereby certify that a certified copy of a resolution adopted by the City Council of the City of Willmar Minnesota, on April 6, 2026, levying taxes for the payment of its \$8,460,000 General Obligation Tax Abatement Bonds, Series 2026A, of said municipality dated April 23, 2026, has been filed in my office and said bonds have been entered on the register of obligations in my office and that such tax has been levied as required by law.

WITNESS My hand and official seal this \_\_\_\_\_ day of \_\_\_\_\_, 2026.

---

County Auditor/Treasurer  
Kandiyohi County, Minnesota



### City Council Action Request

<b>Council Meeting Date:</b>	April 6, 2026	<b>Agenda Item Number:</b>	9.E.
<b>Agenda Section:</b>	Regular Business	<b>Originating Department:</b>	Public Works
<b>Resolution:</b>	Yes	<b>Prepared By:</b>	Kelsi Delbosque, Administrative Assistant
<b>Ordinance:</b>	No	<b>Presented By:</b>	Shane Stefanick, Public Works Director
<b>Item:</b>	City Hall Elevator Modernization Upgrades		

**RECOMMENDED ACTION:**

Staff recommends MEI Total Elevator Solutions. MEI has provided a comprehensive pricing package and does not require subcontractors. The company has also serviced the City Hall elevator for many years, demonstrating familiarity with the equipment and facility.

Motion by \_\_\_\_\_, seconded by \_\_\_\_\_, to adopt the resolution approving an agreement with MEI Total Elevator Solutions for the City Hall Elevator Modernization Upgrades in the amount of \$144,787.

**OVERVIEW:**

The City Hall elevator is currently out of compliance with state code for correct equipment. Minnesota adopted ASME A17.3-2015 - Safety Code for Existing Elevators has been updated for "door lock monitoring". This requirement ensures that an elevator will not operate if the hoistway door interlock or car door gate switch circuitry were either bypassed or failed in a way that renders the circuitry bypassed. The City Hall elevator needs a new elevator controller and power car doors installed to comply with this requirement. Staff obtained two quotes for the project; one from MEI Total Elevator Solutions in the amount of \$144,787, and one from Metro Elevator & Hamline Construction in the amount of \$136,918.

**BUDGETARY/FISCAL ISSUES:**

The project is funded from the 2026 CIP.

**ALTERNATIVES TO CONSIDER:**

**ATTACHMENTS:**

1. Resolution- Accept Quote City Hall Elevator Project
2. MEI Quote
3. Metro Elevator Quote

**Resolution No.**\_\_\_\_\_

**A RESOLUTION AWARDING THE CITY HALL ELEVATOR MODERNIZATION UPGRADES PROJECT TO MEI TOTAL ELEVATOR SOLUTIONS IN THE AMOUNT OF \$144,787.**

Motion By:\_\_\_\_\_ Second By:\_\_\_\_\_

BE IT RESOLVED by the City Council of the City of Willmar, a Municipal Corporation of the State of Minnesota, that the quote for the City Hall Elevator Modernization Upgrades is accepted, and be it further resolved that the Mayor and City Administrator of the City of Willmar are hereby authorized to enter into an agreement with the bidder for the terms and consideration of the contract in the amount of \$144,787.

Dated this 6th day of April, 2026

\_\_\_\_\_  
Mayor

Attest:

\_\_\_\_\_  
City Clerk

Date: 3/03/2026

QUOTE NUMBER: 25114 - Rev 1

**Elevator Modernization Agreement**

**EQUIPMENT LOCATION:**

WILLMAR CITY OFFICES  
333 6TH ST SW  
WILLMAR, MN 56201-3457

**SUBMITTED TO:**

WILLMAR CITY OFFICES PO  
BOX 755  
WILLMAR, MN 56201

**ELEVATOR DESCRIPTION:**

**Elevator ID:** MN1026659

**Description:** ELEV 1 - MEI HP-121

**ATTN:**

Shane Stefanick  
320-214-5171  
sstefanick@willmarmn.gov

**Type of Work: Modernization**

This Modernization Agreement ("**Agreement**") is proposed as of this 3rd day of March, 2026 ("**Effective Date**") between MEI Total Elevator Solutions ("**MEI**"), and "**Customer**": WILLMAR CITY OFFICES, PO BOX 755, WILLMAR, MN 56201. MEI and Customer are collectively referred to herein as the "**Parties**" or individually as a "**Party**". MEI proposes to furnish certain maintenance services to Customer as provided herein.

**Scope of Work:**

**MEI is providing this proposal to perform the following work:**

**MODERNIZE 3 STOP VIRGINIA CONTROLS**

MEI to Provide material and labor to replace the following:

**NEW CONTROLLER:**

- New solid-state controller with a built in soft start as manufactured by Vertiron Midwest, Inc. This controller will be non-proprietary.

**NEW FIXTURES: Brushed Stainless Steel**

- New emergency ADA phone
- New emergency car lighting within car operating panel
- New car direction lantern
- New Hall PI Fixture

**NEW POWER UNIT**

- New MEI power unit
- New hydraulic oil
- New jack packing
- New seals as necessary in the machine room and hoistway

**NEW DOOR EQUIPMENT: Nonproprietary Closed Loop**

- New closed loop door operator
- New photo edge to keep the doors from hitting tenants and injuring them
- New door restrictor per code compliance
- New escutcheon locks on all hoistway doors
- New hanger rollers, clutch, pickup rollers, locks and closers as needed

**NEW HOISTWAY EQUIPMENT:**

- New selector for smooth transition into leveling
- New cartop station per code compliance
- New Pit stop switch
- Add emergency stop switch for code compliance
- New gfci/pit light

**HOSTWAY & MACHINE ROOM WIRING:**

- All associated wiring to the work listed in this contract will be new.

**MISCELLANEOUS ITEMS:**

- Third Party Inspection is included with this work
- Operation and Maintenance Data
- Related Work Included in Bid

Date: 3/03/2026

QUOTE NUMBER: 25114 - Rev 1

Subject to the provisions of this Agreement, MEI will perform the work as described in this section. If Customer requests services not listed, Customer agrees to pay MEI for such additional work at MEI's then-current rates. The Work will be provided pursuant to the terms and conditions in this Agreement and MEI's Terms and Conditions (the "T&C").

---

**Price:**

**\$144,787.00**

The pricing in this agreement is only valid for 45 days from the date listed above.

---

**Payment Terms:**

All Modernization Fees are due and payable to MEI on the following schedule:

- 40% of the Modernization Fee is due at the time of signing this Agreement. Customer understands that MEI will not order parts or materials, or schedule the Work, until this payment has been received by MEI.
- 35% of the Modernization Fee will be billed when a majority of the materials have been received. Customer understands that MEI will not schedule the Work until this payment has been received. Customer understands that timing issues may result in needing to expedite this payment.
- The Balance (approximately 25%) of the Actual Modernization Fee will be billed upon completion of the Work. The payment terms for this portion of the Work will be due in Net 30 terms.

If Customer fails or refuses to pay MEI all or any part of the Fees when due, MEI may use any remedy specified in the T&C. Invoices issued under this Agreement for additional work will be billed as the work is performed and are due and payable to MEI on a Net 30-day basis. If, at any time, the Work is terminated by either Party, MEI will issue a final invoice to the Customer. Customer agrees to immediately issue payment to MEI for all work completed up to the termination date.

---

**Agreement Terms**

The Term of this Agreement starts when fully executed by both Parties and terminates when the Work is performed by MEI and paid for by Customer. Notwithstanding the foregoing, if Customer has not made any preliminary payment required in Payment Terms within 15 days of signing this Agreement, MEI may terminate this Agreement upon notice to Customer, and without any liability to Customer.

The provision of the Work and payment therefore is subject to, and Customer agrees to be bound by the T&C as published by MEI from time to time, a current copy of which is attached hereto. This Agreement: (i) may be executed in counterparts, including electronic counterparts, each of which shall be deemed an original but all of which shall be deemed one and the same Agreement; (ii) is binding upon and inures to the benefit of MEI and Customer and their respective successors, transferees, or assignees; (iii) together with the T&C, constitutes the entire agreement between the Parties with respect to the subject matter hereof, superseding all prior agreements, representations, communications and understandings, oral or written; and (iv) may not be amended except by a written agreement signed by both Parties. If there is a conflict between the terms of this Agreement, and the T&C, this Agreement shall govern and supersede the T&C.

By signing this Agreement, Customer hereby applies for credit and affirms financial responsibility, ability and willingness to pay invoices in accordance with the terms of this Agreement as well as any additional work requested by the Customer which may be done outside this Agreement. The above information is warranted to be true and complete. Customer hereby authorizes MEI to verify and collect information on Customer, including but not limited to bank references, trade credit references, consumer and/or commercial credit reports. Customer agrees to pay: (i) a monthly finance charge equal to the maximum applicable state rate on all past due balances; and (ii) all costs of collection and attorney's fees incurred by MEI arising from any default by Customer under this Agreement. Customer agrees that all decisions with respect to the extension or continuation of credit shall be in the sole discretion of MEI.

---

**Acceptance of Proposal**

**IN WITNESS WHEREOF**, each Party represents that it has caused this Agreement to be executed by an authorized agent or representative who, on the date of such signing, has the necessary authority, corporate, municipal, or otherwise, to bind the Party. By signing below, Customer agrees to engage MEI to perform the Work in accordance with this Agreement and the T&C and agrees to pay for all Work.

(CUSTOMER)

Approved by Authorized Representative

Accepted by:

MEI Total Elevator Solutions

Approved by Authorized Representative



# MEI

TOTAL ELEVATOR SOLUTIONS

Twin Cities Office  
2333 Waters Dr  
Mendota Heights, MN 55120  
Phone: (612)338-3774 Fax: (507)245-4198  
www.meiusa.com

Date: 3/03/2026

QUOTE NUMBER: 25114 - Rev 1

Signed: \_\_\_\_\_

Signed: \_\_\_\_\_

Date: \_\_\_\_\_

Date: \_\_\_\_\_

Print Name: \_\_\_\_\_

Print Name: Spencer Mack

Title: \_\_\_\_\_

Title: Service Operations Manager

Phone: \_\_\_\_\_

Phone: 320-339-0007

Email: \_\_\_\_\_

Email: spencer.mack@meiusa.com

Name of Company: \_\_\_\_\_

Customer Purchase Order: \_\_\_\_\_

Principal, Owner or Authorized Representative or Owner

Agent: \_\_\_\_\_  
(Name of Principal or Owner)

Date: 3/03/2026

QUOTE NUMBER: 25114 - Rev 1

**MEI STANDARD EXCEPTIONS/QUALIFICATIONS/NOTES:**

- This bid is valid only if a mutually agreeable contract, schedule and completion date can be obtained. Any changes must be seen and agreed to by MEI in writing.
- Installation must begin within six (6) months of contract date, or as shown on the published construction schedule. If installation does not begin within six (6) months of the contract date or as shown on published construction schedule, the project may be subject to an escalation fee for material costs and labor rate increases. Price is subject to change if any customer supplied information changes after booking, or upon review of additional and or updated information.
- If MEI is forced to store elevator equipment in warehouse due to a customer initiated install start date change, the customer will be responsible for additional storage fees.
- MEI does not carry professional liability insurance. Professional liability insurance will not be provided if bid is accepted.
- Our bid is based on timely return of all approved submittal drawings and allowing for manufacturing lead-time of 12 weeks after approvals.
- Exception is taken to any ambiguous, vague, not clearly evident in bid information and/or inexplicit liquidated damage stipulations.
- Exception is taken to retainage in excess of (5%) five percent.
- Exception is taken to any retainage if a performance/payment bond is required.
- Exception is taken to retainage for clean-up.
- Minnesota Elevator has included the necessary mobilization to and from this project in the above bid. If for any reason beyond our control; MEI is forced into additional mobilization on this project, (incomplete hoistway or machine room, lack of power, etc.) a remobilization fee of \$7,500.00 will be charged for each occurrence.
- On-site storage, approximately 20'x25' per elevator adjacent to the hoistway at bottom landing is required. If off-site storage is required, an additional charge will be assessed for the first three months to cover any double handling, storage or re-transportation of elevator material required by the general contractor/owner or agent thereof. After the first three months, an additional monthly charge will be assessed for storage until the material arrives on site.
- Bid includes one inspection per state permit. If more than one inspection is needed due to causes other than MEI, additional charges of then current hourly rate of MEI plus any applicable state re-inspection fees will be assessed.
- This bid does not include any provisions for construction use of the elevator.
- Should temporary service be required it will be provided via a CHANGE ORDER, as requested, per elevator. The Owner/General Contractor will be responsible for operators, protection of the elevator, and restoration costs of the elevator after the temporary service is complete. Owner/General Contractor will also be responsible for any additional inspection, permitting fees, and inspection time involved with the temporary service.
- This bid does not include any provisions for owner instruction and or training
- Certificates for Two million General Liability Insurance and Ten Million Umbrella Insurance coverage will be issued.
- If additional crews are requested and MEI has the resources to accommodate this request there will be a minimum charge of \$7,500.00 (MEI has provided one crew for this bid).
- This bid will become a rider, attachment or addendum to any contract issued.
- Any contract resulting from this bid is conditioned on neither party being liable to the other for any loss, damage or delay due to any cause beyond your or our reasonable control, including but not limited to acts of government, strikes, lockouts, fire, explosion, theft, floods, riot civil commotion, war, malicious mischief or act of God. Under no conditions, shall either party be liable for special, indirect, or consequential damages in contract tort, including negligence, warranty or otherwise, notwithstanding any indemnity provisions to the contrary.
- Permanent power to be provided by others to hoistway and machine room.
- Hoisting beam to be furnished and installed by others.
- Two (2) overhead hoist beams suitable for supporting the weight of the elevator equipment must be sized, furnished and installed by the G.C./customer. Hoist beams may need to be removed after elevator installation is complete, if overhead clearance codes are not met.
- Cutting, patching, grouting and fire caulking will be done by others at no cost to MEI.
- Flooring provided and installed by others.
- Pit floor and walls must be finished and backfilled before we can start.
- GC must provide forklift or appropriate handling equipment to unload MEI equipment at no cost to MEI.
- Barricading to be provided by others. MEI will replace barricade we remove as part of our work.
- Solid barricades at least 8 ft (2.4 m) high shall be supplied and installed by the G.C., customer, or owner to fully enclose work areas, open hoistways and escalator wellways. Barricades shall be properly secured to avoid unauthorized access from the general public.
- Disposal of construction debris and packaging resulting from this installation or removal will be by others.
- MEI will place debris in dumpster or other receptacle provided and paid for by others or as reasonably directed.

**Disposal Contaminated Oil or Hydraulic Fluid (as applicable):**

MEI will not be responsible for the disposal of any contaminated soil or hydraulic fluid that is removed from the cylinder hole. We will also not be responsible for any required clean up costs, fines or penalties that may result from this oil loss. Notification of the EPA and inspection of the ground soil is the responsibility of the owner, if they elect to do so.

Date: 3/03/2026

QUOTE NUMBER: 25114 - Rev 1

### MEI TERMS AND CONDITIONS ("T&C")

**1. Purchase and Payment.** Pursuant to the applicable Repair Agreement, purchase order or quote (collectively, "Agreement"), Customer agrees to purchase the parts, machinery or equipment (collectively, "Product") or Work described in the Agreement. Except as defined herein, all capitalized terms have the meaning ascribed to them in the Agreement. Customer agrees to pay all sums specified in the Agreement within 2 days of the due date, without any deduction or setoff. MEI reserves the right to add all applicable taxes as prescribed by law. Customer shall pay any and all of Customer's third-party vendor fees, such as, but not limited to accounts receivable / payable administrators. All credit card payments made by Customer may be subject to the addition of credit card processing fees. If customer elects to pay MEI by credit card, Customer agrees to these fees. Customer agrees to receive MEI's invoices electronically, and if Customer requires other delivery, shall pay MEI's then-current delivery fee.

**2. Standard Warranty.** MEI warrants that any new Product, including materials and equipment to be furnished as part of the Product or Work, shall be of good quality, in conformance with all legal requirements, and will be free from defects in material and workmanship for twelve (12) months from the date of installation (the "Standard Warranty"). Any refurbished parts, if available, carry a warranty that such parts shall be of good quality and free from defects in materials and workmanship for a period of ninety (90) days from installation. This Standard Warranty shall not apply to: (i) any Product that has been subject to misuse, misapplication, neglect (including without limitation improper maintenance and storage), accident, improper installation, modification (including without limitation use of unauthorized parts of attachments), adjustment or repair; or (ii) damage, loss, or diminution of or to any Product related to normal wear and tear, or usage of wear parts. (iii) damage caused by disasters such as fire, flood, wind, lightning, electrical surge or power outage; (iv) corrosion from exposure to liquids or atmospheres; (v) any parts or components installed or modified by a non-MEI mechanic after the completion of the Work; or (vi) Customer's failure to properly clean or care for the Product after completion of the Work. Notwithstanding any contrary provision or agreement, MEI's maximum liability for Products, whether in contract, negligence, or strict liability in tort, is limited to the repair or replacement of the Product at issue, or the parts thereof.

**3. Repair Terms and Conditions.** Customer shall: (i) cooperate with MEI in all matters relating to the Work, and respond promptly to MEI's request to provide direction, information, approvals, authorizations and decisions; and (ii) obtain and maintain all necessary permits related to the equipment; and provide all wiring prints and diagrams and a copy or version of the controller software. Customer agrees to provide MEI with full immediate access to all areas of Customer's facility in which the elevator(s) and associated equipment is located in order to perform the Work in the Agreement. Failure to provide such access will result in the Fees being earned and payable by Customer, even if the applicable Work is not completed. Customer shall provide a clear and accessible machine rooms(s) and elevator pit area(s) for the Work to be completed. The machine room and elevator pits must be free from water, debris and stored materials. MEI is not responsible or liable for personal injury or property damage due to the action or failure of any part of the elevator equipment during testing. If subsequent repairs are necessary to obtain proper operation of the equipment to meet the requirements of these tests, such work will be proposed at additional cost under separate work order. Any testing of emergency/standby power systems that require immediate completion will be billed at current charge out rates and in addition to the Repair Fee. In accordance with OSHA requirements, Customer shall inform MEI and its employees who will perform work activities in areas which contain ACM and/or PACM of the presence and location of ACM and/or PACM in such areas which may be contacted during work before entering the area. Other than as expressly disclosed in writing, Customer warrants that MEI's work area at all times meets applicable OSHA permissible exposure limits (PEL's). Notwithstanding anything contained to the contrary within this bid or contract: (a) MEI's work shall not include any abatement or disturbance of asbestos containing materials (ACM) or presumed asbestos containing materials (PACM); (b) Any work in a regulated area as defined by Section 1910 or 1926 of the Federal OSHA regulations is excluded from MEI's scope of work without an applicable change order to reflect the additional costs and time; (c) MEI shall have the right to discontinue its work in any location where suspected ACM or PACM is encountered or disturbed, and the time period specified in the bid or contract for MEI to complete its work shall be extended until the same is abated; and (d) Any asbestos removal or abatement, or delays caused by such, required in order for MEI to perform its work shall be the Customer's sole responsibility and expense. After any removal or abatement, Customer shall provide documentation that the asbestos has been abated from the MEI work area and air clearance reports shall be made available upon request prior to the start of MEI's work.

**4. Limitations.** Unless directly resulting from MEI's gross negligence or willful misconduct, nothing herein or in the Agreement shall be construed to mean that MEI assumes any liability for any accidents or injury to persons or property. Customer retains all liability and responsibility for accidents or injuries to any person or property while riding on or being in or about the subject elevators or related equipment.

(a) **DAMAGES.** IN NO EVENT SHALL MEI OR ANY OF ITS EMPLOYEES, OFFICERS, MANAGERS, DIRECTORS, OWNERS, SUCCESSORS OR ASSIGNS BE LIABLE UNDER THE AGREEMENT OR THESE T&C TO CUSTOMER OR ANY THIRD PARTY FOR ANY CONSEQUENTIAL, INCIDENTAL, INDIRECT, EXEMPLARY, SPECIAL OR PUNITIVE DAMAGES, INCLUDING ANY DAMAGES FOR BUSINESS INTERRUPTION, LOSS OF USE, DATA, REVENUE OR PROFIT, WHETHER ARISING OUT OF BREACH OF CONTRACT, TORT (INCLUDING NEGLIGENCE) OR OTHERWISE, REGARDLESS OF WHETHER SUCH DAMAGES WERE FORESEEABLE AND WHETHER OR NOT CUSTOMER WAS ADVISED OF THE POSSIBILITY OF SUCH DAMAGES.

(b) **MAXIMUM LIABILITY.** EXCEPT WHERE A LIABILITY DIRECTLY RESULTS FROM MEI'S GROSS NEGLIGENCE OR WILLFUL MISCONDUCT, WITHOUT LIMITING THE PROVISION OF SECTION 4(a), IN NO EVENT SHALL MEI'S AGGREGATE LIABILITY EXCEED, WITH RESPECT TO PRODUCTS OR SERVICES, THE GREATER OF: (I) \$25,000; OR (II) THE TOTAL AMOUNT PAID TO MEI PURSUANT TO THE AGREEMENT IN THE TWELVE-MONTH PERIOD PRECEDING THE EVENT GIVING RISE TO THE CLAIM. The prior sentence limiting liability and damages is a material part of the Agreement, and MEI would not have sold the Product or provided the Services on terms as favorable to Customer as set forth in the Agreement.

(c) **EXCLUSIVE REMEDY.** CUSTOMER'S SOLE REMEDY WITH RESPECT TO PRODUCTS SHALL BE THE STANDARD WARRANTY, AND MEI'S SOLE LIABILITY SHALL BE COMPLIANCE WITH THE STANDARD WARRANTY.

Date: 3/03/2026

QUOTE NUMBER: 25114 - Rev 1

**5. Indemnification.** Each Party (as "*Indemnifying Party*") shall indemnify, defend and hold harmless the other Party and its officers, managers, directors, employees, successors and assigns (collectively, "*Indemnified Party*") against all losses, damages, liabilities, claims, actions, judgments, settlements, awards, costs, or expenses of whatever kind, including reasonable attorneys' fees, actually incurred by Indemnified Party or actually awarded against Indemnified Party, resulting from: (i) breach or non-fulfillment of any representation, warranty or covenant under the Agreement by Indemnifying Party, its employees or agents; (ii) any negligent or more culpable act or omission of Indemnifying Party and its employees and agents (including without limitation reckless or willful misconduct) in connection with the performance of its obligations under the Agreement; (iii) bodily injury, death of any person or damage to real or tangible personal property caused by the negligent or more culpable acts or omissions of Indemnifying Party, its employees or agents (including any reckless or willful misconduct); or (iv) any failure by Indemnifying Party to comply with any applicable federal, state or local laws, regulations or codes in the performance of its obligations under the Agreement. Notwithstanding the foregoing, MEI shall not be obligated to indemnify any Customer Indemnified Party if the loss or damage arises from or relates to breach of the Agreement by, or negligence or misconduct of, Customer or its employees, agents, managers, representatives or contractors.

**6. Default.** An event of default ("*Event of Default*") under the Agreement or these T&C shall occur upon the occurrence of all or any one of the following events: (i) Customer does not pay any amount due to MEI under the Agreement; (ii) Customer ceases doing business as a going concern; (iii) Customer makes an assignment for the benefit of its creditors or admits in writing to its inability to pay its debts as they become due; (iv) Customer files, or has filed against it, a petition in bankruptcy or for its reorganization, arrangement, composition or readjustment under any state insolvency law or Customer liquidates all or a substantial part of its assets not in the ordinary course of its business, dissolves or takes other similar action; or (v) Customer shall default in the performance of any of its obligations arising under the Agreement, these T&C, any service schedule, or any other agreement between Customer and MEI, and such default is not cured within fifteen (15) days of MEI providing notice of same. MEI shall not be default of this Agreement unless and until Customer has notified MEI in writing of the alleged default, and MEI has had thirty (30) days to remedy the alleged default.

**7. Remedies.** Upon the occurrence of any Event of Default, MEI may at its option and without notice or demand, exercise all or any one of the following remedies: (a) upon written notice to Customer, terminate this Agreement and any other agreement between Customer and MEI; and/or (b) take additional action as may be appropriate to mitigate additional damages to MEI; The foregoing remedies are cumulative and may be exercised successively or concurrently.

**8. Assignment.** MEI may without the consent of Customer, assign MEI's rights and obligations under the Agreement, and may subcontract any portion of MEI's performance of the Agreement to a third-party. Customer may not assign the Agreement or otherwise transfer its rights or obligations under the Agreement to any third-party without the prior written consent of MEI. In the event of the sale, lease, assignment or other transfer of Customer's facility described herein, Customer agrees to disclose in writing to such successor the Agreement, and if all of Customers' obligations under the Agreement are not assumed in writing by such successor, Customer agrees to continue to be bound by the terms hereof.

**9. Governing Law; Venue.** The validity, construction and performance of the Agreement and these T&C shall be governed by and construed in accordance with the law of the state where the Services are performed, without reference to any choice of law principals, but the specific performance provisions and right of MEI to seek injunctive relief for Customer's breach of the covenants contained herein may also be enforced in any other state wherever such breach occurs, and in accordance with the laws of such other state, to the extent necessary to secure enforcement in such other jurisdiction.

**10. Force Majeure.** MEI shall not be liable for any failure of performance hereunder due to causes beyond its reasonable control, including but not limited to: act of God, fire, flood, earthquake, terrorist act, national emergency, war, strike, lock-out, change in law, work stoppage or other labor difficulty, action or inaction of an independent third party utilized in providing the Services, or unavailability of materials.

**11. Waiver of Jury Trial.** Each Party agrees that any controversy that may arise under the Agreement, including schedules attached to the Agreement, is likely to involve complicated and difficult issues and, therefore, each Party irrevocably and unconditionally waives any right it may have to a trial by jury in respect of any legal action arising out of or relating to the Agreement, or the transactions contemplated hereby.

**12. General Provisions.** The following sections of the T&C shall survive termination or expiration of the Agreement: 2, 3, 4, 5, 6, 7, 9, 10, 11, and 12. The relationship of the parties created by the Agreement is that of independent contractors and not partners, joint ventures, agents, or otherwise. No waiver by either Party of any right under, or breach of, any provision of the Agreement shall be construed as a waiver of any continuing or succeeding breach of such provision or right. The Agreement these T&C: (i) are binding upon and inure to the benefit of MEI and Customer and their respective successors, transferees, or assignees; and (ii) constitute the entire agreement between the Parties with respect to the subject matter of the Agreement, superseding all prior agreements, representations, communications and understandings, oral or written. A determination that any provision of the Agreement is invalid or unenforceable shall not affect the other provisions of the Agreement. The Agreement may not be amended or modified except by a written agreement signed by both Parties. In the event of a conflict between the main body of the Agreement and these T&C, these Agreement will take precedence, and shall supersede and be controlling over the T&C. By accepting delivery of the Products or Services, Customer is also agreeing to these T&C. Except for the money due upon an open account, no action may be brought for any breach of the Agreement or these Terms and Conditions more than one (1) year after the accrual of such cause of action. Customer agrees to receive invoices, notices and other communications under this Agreement at the address listed in the Agreement until Customer notifies MEI in writing of any changes in mailing address. Failure to notify MEI of any address changes does not change the delivery status of delivered invoices or other notices. Customer agrees to promptly notify MEI of any billing errors and understands that its failure to notify MEI does not change the due date or payment status of an invoice.

## Modernization Agreement

**Date:** November 7, 2025

**Attn:** Kelsi Delbosque, 320-214-5170, [kdelbosque@willmarmn.gov](mailto:kdelbosque@willmarmn.gov)

**Location:** Willmar City Offices, 333 6<sup>th</sup> St SW, Willmar, MN 56201

**Equipment:** *One Hydraulic Passenger Elevator – State ID # ELV-1026659*

We are pleased to provide the following proposal for comprehensive modernization of the elevator at the above referenced building.

### MACHINE ROOM RELATED EQUIPMENT

Furnish and install new non-proprietary submersible power unit consisting of oil reservoir tank, submersible pump, valve, motor, muffler, and oil line shut-off valve.

Furnish and install hydraulic oil line, as needed, to accommodate the new power unit.

Furnish and install new oil line fitting seals as needed in the machine room and hoistway.

Provide all new hydraulic fluid.

Furnish and install non-proprietary solid state hydraulic control system including the following features:

- Simplex, selective-collective operation
- Fire service phase-I and II operation
- Inspection
- Top and Bottom hoistway access
- Car top inspection
- Solid state starter
- Door Lock Monitoring

Furnish and install new car wiring, machine room wiring, hoistway wiring and car traveling cable, including new wiring duct, piping and greenfield as required.

Furnish and install a code data tag on new elevator controller, per code.

### CAR FIXTURES

Furnish and install a new non-proprietary car operating station manufactured by Innovation Industries in the front return panel at the required handicap height. The new car operating station will include the following features:

- Illuminated car call registration buttons.
- Dot Matrix Car Position Indicator with 2" display and directional arrows.
- Emergency light unit
- Braille located adjacent to all buttons/features used by general public.
- Door open button.
- Door close button.
- Alarm bell button.
- Separate lockable fire service cabinet equipped with all required fire service phase-II features and signage.
- Inspection service key switch.
- Independent service key switch.
- Light key switch
- 2-Speed Fan key switch

- In-car keyed stop switch.
- ADA phone/speaker grille/handicap symbols
- Nudging buzzer/Floor passing chime.
- Engraving of Capacity

Furnish and install a non-proprietary car travel lantern on the return columns that will be visible from the hall stations. The lanterns will be equipped with light-up visible arrows and 1-2 stroke audible chimes, per handicap code.

Install stainless steel plates where the existing car position indicator and phone box are located. These items will now be part of the new car operating station.

## CAR/HOISTWAY DOOR EQUIPMENT

Furnish and install new non-proprietary car door equipment manufactured by GAL Manufacturing consisting of GAL MOVFR-II car door operators, door detectors, and restrictor clutches.

Furnish and install car and hall door gibs and safety retainers at each landing.

Provide access holes with keyed plug locks on existing hoistway door panels at the upper landings per code.

Furnish and install the following door equipment as needed: door rollers, door closer assemblies, pick-up roller assemblies, interlock assemblies, and gate switches.

## LOBBY EQUIPMENT

Furnish and install new non-proprietary hall station fixtures manufactured by Innovation Industries at each landing at the required handicap height.

- The hall station fixture at floor \*M will be equipped with illuminated hall call registration buttons, a fire service phase-I key switch, a fire service jewel, fire service phase-I instructions, an audible/visual device for monitoring the telephone line and engraved appendix "O" emergency signage.
- The hall station fixtures at floors L & 2 will be equipped with an illuminated hall call registration button and engraved appendix "O" emergency signage.

New hoistway access stations will be installed at the terminal landings.

Furnish and install a new position indicator at floor \*M above the opening.

## PIT RELATED EQUIPMENT

Furnish and install pit stop switch.

Furnish and install pit ladder.

Furnish and install a new jack packing.

## CAR TOP AND CAR BOTTOM RELATED EQUIPMENT

Furnish and install cross head data tag.

Furnish and install hoistway selector package, including limit switches, leveling switches, door zone switches, directional switches, vanes and related hardware.

Furnish and install a new car top inspection station with light, light guard, GFCI outlet and fire service features, per code.

Install electrical switch on car top emergency exit, per code.

## PRICING/TERMS AND CONDITIONS

Metro Elevator, Inc. is proposing to furnish the necessary labor and materials required to perform the elevator work above for the net sum of One Hundred Seven Thousand Three Hundred Thirty-Four & 00/100 Dollars (\$107,334.00).

Alternate #1, install a pit shut off valve  
Add \$656.00

Alternate #2, install stainless steel car doors inside the elevator (price is total for two sets)  
Add \$3,936.00

Alternat #3, clean and paint the pit equipment to prevent rusting  
Add \$910.00

Alternate #4, add hall call security to restrict access to the elevator at the main landing. (controller features, wiring, labor). Reader, installation of reader, and interface to be completed by others.  
Add \$3,269.00

The above-quoted price also includes the following:

- All permits and fees associated with our scope of work.
- Elevator Inspection.
- 12-months of parts warranty on all replaced components.
- Coordination efforts with Hamline Construction for the related building work

The above-quoted price does not include the following:

- Elevator interior finished flooring
- Elevator phone line

The quote is also based on the current edition of the ANSI code being enforced in Minnesota at the time of this bid.

All work is to be performed during regular working hours of the elevator trade.

The quoted price is based on the proposal being accepted within 30-days from proposal date.

## PAYMENT TERMS

Payment terms are as follows:

50% due with signed contract.  
40% due upon receipt of material.  
10% due upon completion.

Payments not received within thirty days of the date of the invoice shall be subject to interest accrued at the rate of 18% per year or at the maximum rate allowed by law, whichever is less. We shall also be entitled to reimbursement from you of the expenses, including attorney's fees, incurred in collecting any overdue payments.

It is understood this Proposal is submitted for acceptance within 30 days from date executed by ME.

Your acceptance of this Proposal and its approval by an executive officer of Metro Elevator will constitute exclusively and entirely the agreement for the service herein described. No other changes in or additions to this agreement will be recognized unless made in writing and properly executed by both parties.

IN WITNESS WHEREOF, the parties have caused this Agreement to be duly executed by their authorized representatives on the day and year first above written.

## Approvals:

Metro Elevator

Customer

By: \_\_\_\_\_

By: \_\_\_\_\_

Signature: \_\_\_\_\_

Signature: \_\_\_\_\_

Title: \_\_\_\_\_

Title: \_\_\_\_\_

Date: \_\_\_\_\_

Date: \_\_\_\_\_

## WARRANTY

All workmanship is guaranteed against defects in workmanship for a period of one year from the date of installation, provided the elevator has an active preventative maintenance program with Metro Elevator (ME). Metro Elevator's obligation under this warranty shall be limited to repairing, replacing, or issuing credits for- at Metro Elevator's option- any products or services it finds to be defective in material or workmanship. In no event shall Metro Elevator be liable for incidental, consequential, or indirect damages of any kind. Metro Elevator shall not be responsible for damage to its work by other parties. Any repair work necessitated by caused damage will be considered as an order for extra work. **THIS WARRANTY SHALL BE IN LIEU OF ANY OTHER WARRANTY, EXPRESSED OR IMPLIED, INCLUDING ANY WARRANTY FOR MERCHANTABILITY OR FITNESS FOR ANY PARTICULAR PURPOSE.** Unless otherwise specified, repaired/refurbished equipment will be warranted for 30 days after installation.

## Insurance

Metro Elevator shall provide worker's compensation insurance for its own employees; property and casualty insurance for its own property, materials and equipment; vehicle liability for its vehicles and drivers; and commercial general liability insurance in an amount not less than One Million Dollars (\$1,000,000) combined single limit. Upon request by Customer, ME shall provide to Customer a certificate of such insurance.

## Indemnification

Each party shall indemnify and hold harmless the other party from all third party claims resulting in liabilities, losses, costs, damages, judgments or expenses, including reasonable attorneys' fees and costs of litigation, to the extent caused by the negligence or willful misconduct of the indemnifying party, provided the indemnified party gives prompt notice of such claims and cooperates with the other party in the defense of such claim.

## Limitation of Liability

ME does not assume possession or control of any part of the Equipment. Notwithstanding anything to the contrary in this Agreement, in no event shall either party be liable to the other for any special, consequential or incidental damages in connection with this Agreement arising from the performance or breach of any obligations under this Agreement. Metro Elevator shall not be responsible for delays or extra costs caused by any circumstances beyond our control, including delays caused by the purchaser, contractor, sub-contractor, architect, transportation, raw materials, tariffs, strikes, theft or vandalism, civil disorder and Acts of God. ME shall bill at our regular rates for additional costs incurred due to such circumstances, including re-inspections for work that is not part of this agreement



3/6/2026

To: Zach Miller - Metro Elevator

RE: Willmar City Offices Elevator MOD - Simplex Hydro / 3 Stops (1 Rear)  
333 6th Street SW.  
Willmar, MN

Zach,

Thank you for the opportunity to bid this project for you. After reviewing the jobsite, we propose to provide all permits, labor, tools, materials, equipment, and supervision to complete the "related work" for the elevator modernization project. The work we will perform is listed below.

### **Machine Room**

Provide and install required elevator equipment room signage to meet code.  
Remove existing lockset from machine room door and replace with new store room function.  
Make machine room HVAC code compliant.  
Remove fire sprinkler from machine room and patch hole(s) as required.  
Patch machine room walls and ceiling as required to meet code.  
Pipe and wire new controller from existing disconnect with true earth ground. *\*If battery lowering desired, see alternates.*  
Provide necessary lighting, switch and GFI's in machine room.  
Provide phone pipe to controller. Dedicated phone line to machine room by others.  
Wire car lights.  
Provide necessary fire alarm equipment for automatic recall and connect to new elevator controller.

### **Hoist way/Pit**

Patch holes or voids in hoist way walls/ceiling created by new elevator equipment.  
No HW venting provisions expected or included.  
Provide and install GFCI outlet in pit.  
Provide and install hoist way lighting in pit to achieve 10 FC at pit floor.  
Provide switch for lighting.  
No water remediation work included in this proposal. If work is required it will be handled via change order.  
*\*Car will need to be spotted by elevator contractor for pit work at no cost to Hamline Construction.*

### **Lobbies**

Provide necessary fire alarm equipment for automatic recall and connect to existing FACP.  
Programming and testing for fire service included.  
Standard color, surface mount wire mold if required.  
This FA plan is subject to the approval by the Fire Marshal.  
No fixture cutting included in this proposal as claimed by elevator local #9.  
Fixture patching included for fire rating. No finishes included.





### City Council Action Request

<b>Council Meeting Date:</b>	April 6, 2026	<b>Agenda Item Number:</b>	9.F.
<b>Agenda Section:</b>	Regular Business	<b>Originating Department:</b>	City Clerk
<b>Resolution:</b>	No	<b>Prepared By:</b>	Kyle Box, City Operations Director
<b>Ordinance:</b>	Yes	<b>Presented By:</b>	Vernae Larsen, City Clerk
<b>Item:</b>	Introduction of an Ordinance Amending Willmar Municipal Code, Chapter 8		

**RECOMMENDED ACTION:**

Introduce the ordinance and call for a public hearing on April 20, 2026 at 6:30 PM

**OVERVIEW:**

The referenced sections within the attached ordinance were previously governed by Minn. Stat. 151.72. In February 2025, an ordinance was adopted amending this chapter in response to previous legislative changes under the State of Minnesota’s cannabis legalization framework. With the continued rollout of cannabis licensing through the Minnesota Office of Cannabis Management (OCM), the referenced Minn. Stat. 151.72 is no longer applicable and is now governed under Minn. Stat. 342.

**BUDGETARY/FISCAL ISSUES:**

NA

**ALTERNATIVES TO CONSIDER:**

None Recommended

**ATTACHMENTS:**

1. Ordinance Repealing THC Registration (v2) 040126

ORDINANCE NO. \_\_\_\_\_

AN ORDINANCE OF THE CITY OF WILLMAR, MINNESOTA AMENDING WILLMAR MUNICIPAL CODE, CHAPTER 8, LICENSES, PERMITS AND BUSINESS REGULATIONS BY REPEALING TETRAHYDROCANNABINOL PRODUCTS LICENSING REGULATIONS

The City Council of the City of Willmar hereby ordains as follows:

Section 1. REPEAL OF TETRAHYDROCANNABINOL PRODUCTS LICENSING REGULATIONS. Chapter 8, Licenses, Permits and Business Regulations; Article IX, Tetrahydrocannabinol Products (Sections 8-300 through 8-320), establishing licensing regulations for tetrahydrocannabinol products under Minn. Stat. § 151.72 in the City of Willmar, is hereby repealed in its entirety, and such Article IX (Sections 8-300 through 8-320) shall thereafter be reserved.

Section 2. EFFECTIVE DATE. This ordinance shall be effective from and after its adoption and second publication.

Passed by the City Council of the City of Willmar this \_\_\_ day of \_\_\_\_\_, 2026.

ATTEST:

\_\_\_\_\_  
Vernae Larsen, City Clerk

\_\_\_\_\_  
Doug Reese, Mayor

VOTE:     \_\_\_ SHULDES \_\_\_ GILBERTSON \_\_\_ DAVIS \_\_\_ GARDNER  
          \_\_\_ FAGERLIE \_\_\_ ASK \_\_\_ BUTTERFIELD \_\_\_ NELSEN

This Ordinance introduced by Council Member: \_\_\_\_\_

This Ordinance introduced on: \_\_\_\_\_

This Ordinance published on: \_\_\_\_\_

This Ordinance given a hearing on: \_\_\_\_\_

This Ordinance adopted on: \_\_\_\_\_

This Ordinance published on: \_\_\_\_\_



**City Council Action Request**

<b>Council Meeting Date:</b>	April 6, 2026	<b>Agenda Item Number:</b>	9.G.
<b>Agenda Section:</b>	Regular Business	<b>Originating Department:</b>	City Clerk
<b>Resolution:</b>	Yes	<b>Prepared By:</b>	Vernae Larsen, City Clerk
<b>Ordinance:</b>	No	<b>Presented By:</b>	Vernae Larsen, City Clerk
<b>Item:</b>	Consideration of the Cannabis Registration Application Process		

**RECOMMENDED ACTION:**

Motion by: \_\_\_\_\_ Seconded by: \_\_\_\_\_ to Adopt a Resolution Allowing the City Clerk to contact businesses on the Cannabis Registration waitlist.

**OVERVIEW:**

Cannabis Microbusiness Registration Holder Mary Janes Buds has canceled its registration with the City of Willmar. This business has withdrawn their application with the State of Minnesota for a Microbusiness Cannabis License and has notified the City that their intentions are to no longer pursue a Cannabis Microbusiness Retail License.

The City Clerk is requesting approval by Resolution an established process for filling vacancies in cannabis registration.

**BUDGETARY/FISCAL ISSUES:**

**ALTERNATIVES TO CONSIDER:**

Open the registration up to anyone and just those on the wait list.

**ATTACHMENTS:**

1. Cannabis Registration Application - Resolution

**RESOLUTION NO. \_\_\_\_\_**

**RESOLUTION ESTABLISHING PROCESS FOR FILLING VACANCY IN CANNABIS REGISTRATION**

Motion By: \_\_\_\_\_

Second By: \_\_\_\_\_

WHEREAS, the City of Willmar, Minnesota, has previously established a Cannabis Registration Application process consistent with applicable state law and local ordinance; and

WHEREAS, an applicant previously approved for cannabis registration has voluntarily withdrawn their application or is otherwise unable to proceed; and

WHEREAS, the City of Willmar created and maintained a waitlist of qualified applicants during the most recent cannabis registration period; and

WHEREAS, the City Council desires to utilize an equitable, transparent, and administratively efficient process for filling the resulting vacancy;

NOW, THEREFORE, BE IT RESOLVED by the City Council of the City of Willmar, Minnesota, that the following process is hereby approved:

1. Recognition of Vacancy  
The City Council formally acknowledges that a cannabis registration vacancy exists due to the withdrawal or inability of a previously approved applicant to proceed.
2. Utilization of Established Waitlist  
The City shall utilize the previously established cannabis registration waitlist created during the most recent registration period.
3. Verification of Eligibility  
The next applicant on the waitlist shall be contacted and required to:
  - A. Confirm continued interest in obtaining cannabis registration; and
  - B. Demonstrate that they continue to meet all applicable state, local, and regulatory requirements.
4. Response Timeline  
The City shall establish a reasonable deadline for response. Failure to respond or demonstrate eligibility within the specified timeframe shall result in forfeiture of the applicant's position on the waitlist.
5. Progression of Waitlist  
If an applicant declines, fails to respond, or is determined ineligible, the City shall proceed to the next eligible applicant on the waitlist using the same process.
6. Reopening of Registration  
If no applicants on the waitlist respond or qualify within the established timeframe, the City Council authorizes staff to reopen the cannabis registration process to the public in a manner consistent with applicable laws and policies.

BE IT FURTHER RESOLVED that City staff are authorized to take all necessary administrative actions to implement this process.

Dated this 6th day of April, 2026

---

MAYOR

Attest:

---

CITY CLERK



**City Council Action Request**

<b>Council Meeting Date:</b>	April 6, 2026	<b>Agenda Item Number:</b>	9.H.
<b>Agenda Section:</b>	Regular Business	<b>Originating Department:</b>	City Clerk
<b>Resolution:</b>	No	<b>Prepared By:</b>	Deborah Stulen, Administrative Assistant
<b>Ordinance:</b>	No	<b>Presented By:</b>	Vernae Larsen, City Clerk
<b>Item:</b>	Sale of Low-Potency Hemp Edible Retail 2026 Registration		

**RECOMMENDED ACTION:**

Approve the Sale of Low-Potency Hemp Edible Retail Registration on a Roll Call Vote

**OVERVIEW:**

In accordance with Minn Stat. §342, the following business has been licensed by the State of MN and is requesting registration approval for 2026.

Cobra Corp, located at 1305 S 1st Street, Suite 4A

**BUDGETARY/FISCAL ISSUES:**

\$125.00 application fee per establishment submitted to the City of Willmar.

**ALTERNATIVES TO CONSIDER:**

Deny the application as requested.

**ATTACHMENTS:**

None



### City Council Action Request

<b>Council Meeting Date:</b>	April 6, 2026	<b>Agenda Item Number:</b>	9.I.
<b>Agenda Section:</b>	Regular Business	<b>Originating Department:</b>	City Clerk
<b>Resolution:</b>	No	<b>Prepared By:</b>	Deborah Stulen, Administrative Assistant
<b>Ordinance:</b>	No	<b>Presented By:</b>	Vernae Larsen, City Clerk
<b>Item:</b>	Consideration of Spurs Grill and Bar On-Sale Intoxicating and Sunday Liquor Licenses		

**RECOMMENDED ACTION:**

Approve the Spurs Grill and Bar On-Sale Intoxicating Liquor License for the Fiscal Year April 25, 2026, through April 25, 2027, and the Sunday Liquor License through the Fiscal Year Ending December 31, 2026, on a Roll Call Vote.

**OVERVIEW:**

On February 3, 2026, Spurs Corporation canceled their current liquor licenses. On March 19, 2026, owner Willie Gonzalez, requested once again hold an On-Sale Intoxicating and Sunday Liquor License located at 313 4th Street SW under the name Spurs Corporation dba Spurs Grill and Bar. The Willmar Police Department has completed a background, criminal history, and driving record check. Willie Gonzalez will be the Resident Manager for this establishment.

**BUDGETARY/FISCAL ISSUES:**

\$300.00 Investigation Fee and Prorated \$4,133.33 License Fees

**ALTERNATIVES TO CONSIDER:**

Deny the approval of the requested applications

**ATTACHMENTS:**

None



**City Council Action Request**

<b>Council Meeting Date:</b>	April 6, 2026	<b>Agenda Item Number:</b>	9.J.
<b>Agenda Section:</b>	Regular Business	<b>Originating Department:</b>	Administration
<b>Resolution:</b>	Yes	<b>Prepared By:</b>	Allie Paulsen, Administrative Assistant
<b>Ordinance:</b>	No	<b>Presented By:</b>	Vernae Larsen, City Clerk
<b>Item:</b>	Resolution to Acknowledge Donations for the First Quarter of 2026		

**RECOMMENDED ACTION:**

**OVERVIEW:**

The City regularly receives donations and, pursuant to formerly adopted Council action, allows staff to promptly send a thank-you letter and formally approve the donations quarterly. Attached is the resolution acknowledging the first quarter donations for 2026.

**BUDGETARY/FISCAL ISSUES:**

Q1 donations total: \$19,001.97

**ALTERNATIVES TO CONSIDER:**

None to consider.

**ATTACHMENTS:**

1. Resolution for Q1 Donations 2026

**RESOLUTION NO.**

**ACKNOWLEDGEMENT OF DONATIONS**

Motion By: \_\_\_\_\_

Second By: \_\_\_\_\_

**WHEREAS**, the City of Willmar has received donations which have been acknowledged by the City Administrator expressing the community’s appreciation for the period of January 1, 2026, through March 31, 2026.

<b>Amount</b>	<b>From</b>	<b>For/Purpose</b>
\$400.00	5 Star Walts, LLC	2026 Daddy Daughter Dance
\$300.00	Dooley’s Petroleum	2026 Daddy Daughter Dance
\$750.00	West Central Steel	2026 Daddy Daughter Dance
\$150.00	Henderson Lewis Post 545	Veteran’s Coffee Social
\$500.00	Ryan Clarks Heroes Project	Willmar Police Explorers
\$2,500.00	CentraCare	2026 Community Growth Events
\$1,000.00	Home State Bank	2026 Community Growth Events
\$250.00	Marcus Construction Charitable Fund	2026 Daddy Daughter Dance
\$500.00	Minnesota Masonic Charities	PD Child Safety and Drug Education Program
\$500.00	Sharon Lodge No. 104	PD Child Safety and Drug Education Program
\$250.00	Lisa Liebl	Willmar Police Explorers
\$3000.00	100 Yard Club Inc.	New Football Helmets
\$200.00	Mick Quinn Insurance Agency	2026 Daddy Daughter Dance
\$8,701.97	Willmar Fastpitch Baseball Association	Netting and Cage Improvements

**NOW, THEREFORE, BE IT RESOLVED** by the City Council of Willmar, Minnesota that the City formally accepts the donations as listed.

Dated this 6<sup>th</sup> day of April, 2026

\_\_\_\_\_

MAYOR

Attest:

\_\_\_\_\_  
CITY CLERK



**City Council Action Request**

<b>Council Meeting Date:</b>	April 6, 2026	<b>Agenda Item Number:</b>	9.K.
<b>Agenda Section:</b>	Regular Business	<b>Originating Department:</b>	Administration
<b>Resolution:</b>	No	<b>Prepared By:</b>	Allie Paulsen, Administrative Assistant
<b>Ordinance:</b>	No	<b>Presented By:</b>	Kyle Box, City Operations Director
<b>Item:</b>	Request for Joint Work Session Monday, April 13, 2026		

**RECOMMENDED ACTION:**

Motion by: \_\_\_\_\_ Second by: \_\_\_\_\_ to schedule a joint work session with City Council and Willmar Municipal Utilities Commission for Monday, April 13, 2026, at 1:00 PM at Heritage Bank.

**OVERVIEW:**

Council requested a facilitated Joint Work Session with Municipal Utilities Commission. The session is scheduled for Monday, April 13, 2026, at 1:00 PM at Heritage Bank Community Room..

**BUDGETARY/FISCAL ISSUES:**

**ALTERNATIVES TO CONSIDER:**

**ATTACHMENTS:**

None



**City Council Action Request**

<b>Council Meeting Date:</b>	April 6, 2026	<b>Agenda Item Number:</b>	11.A.
<b>Agenda Section:</b>	Recess for a Closed Session	<b>Originating Department:</b>	Administration
<b>Resolution:</b>	No	<b>Prepared By:</b>	
<b>Ordinance:</b>	No	<b>Presented By:</b>	
<b>Item:</b>	Minn. Stat. § 13D.05, subd. 3(c) - Parcels 95-003-4820, 95-003-4830 and 95-003-4940		

**RECOMMENDED ACTION:**

**OVERVIEW:**

**BUDGETARY/FISCAL ISSUES:**

**ALTERNATIVES TO CONSIDER:**

**ATTACHMENTS:**

None